

Datenblatt für Präzisionswiderstände

TDS Precision Products GmbH
Industriestrasse 1a
CH-8157 Dielsdorf

T + 41 44 885 30 80
info@tds-pp.com
www.tds-pp.com

Shunt (Vollmetall-Widerstand)

Serie SMB



SMB2

SMB1

- Manganin - Shunt-Widerstand
- DC Strommesswiderstand
- Für Nennströme von 5 A bis 1200 A
- Nennleistung 50 mV, 100 mV oder kundenspezifisch
- Spannungstoleranz von $\pm 0,25\%$ (optional $\pm 0,1\%$)

Für Solar- und Windenergie, Schwerindustrie,
Galvanisierung, Batterieladegeräte u.v.m

Elektrische Spezifikation	SMB		
	1	2	3
Nennleistung	50 mV, 100 mV, kundenspezifisch		
Spannungstoleranz	$\pm 0,25\%$ ($\pm 0,1\%$)		
Nennstrom	5...150 A	170...600 A	800..1200 A
TK-Wert (ppm/°C)	± 15 ppm/°C		
Arbeitstemperaturbereich (max.)	-40...+60°C		
Lagertemperaturbereich	-55...+80°C		
Spannungsfestigkeit	750 VDC		

Mechanische Spezifikation	
Widerstandstechnologie / -material	Vollmetall / Manganin
Gehäusematerial	Kupfer
Anschlüsse	Radial Kupfer verzinkt

Typ	Nennstrom in Ampere	Betriebsstrom in Ampere	Widerstandswert @ 50 mV in mΩ	Widerstandswert @ 100 mV in mΩ
SMB1	5	3,33	10	20
	10	6,67	5	10
	15	10	3,333	6,667
	20	13,3	2,5	5
	30	20	1,667	3,333
	50	33,3	1	2
	75	50	0,667	1,333
	80	53,3	0,625	1,25
	85	56,7	0,588	1,176
	100	66,7	0,5	1
SMB2	150	100	0,333	0,6667
	170	113	0,2941	0,5882
	200	133	0,25	0,5
	250	166	0,2	0,4
	300	200	0,1667	0,3333
	400	267	0,125	0,25
	450	300	0,1111	0,2222
	500	333	0,1	0,2
SMB3	600	400	0,0833	0,1667
	800	533	0,0625	0,125
	1000	666	0,05	0,1
	1200	800	0,0417	0,0833

Leistungsminderungskurve

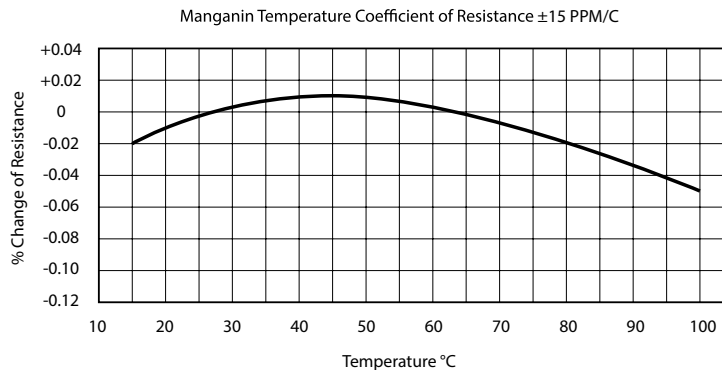

Hinweise

Mounting: Shunts should be mounted with manganin resistive blades in a vertical position in order to promote the free convectional flow of air. If vertical mounting is not practical, forced air cooling or adding heat sinks to the blocks can reduce the operating temperature. The manganin blades must never exceed $+145^{\circ}\text{C}$, otherwise permanent resistance change may occur.

When current of 100A or greater is passing through the shunt, the major portion of heat generated is dissipated by conduction through the shunt terminal blocks into the connecting buss bar or cable. Therefore it is necessary to insure that good contact is made between the shunt terminal blocks and the conductor terminals and that the conductors have adequate cross section to keep the temperature of the shunt from exceeding 145°C (125°C recommended).

If the shunt is mounted in an enclosure, care must be taken to ensure adequate cooling. If the power density is greater than 1/4 watt per square inch of the enclosure surface for all enclosed devices, additional cooling must be supplied in the form of air vents or fans.

Shunts also must be installed in a way that protects them from thermal expansion forces produced from buss bar or short-circuit forces. Flexible wiring may be required in high pulse current, high vibration, or high temperature applications. Where possible, all shunts should be mounted on the ground side of the circuit. For circuits above 750VDC, shunts must be mounted on the ground side due to the dielectric strength of the shunt base.

Operating Current Derating: For continuous operation, it is recommended that shunts are not run at more than two thirds (2/3) the rated current under normal conditions per IEEE standards for DC instrument shunts. At ambient temperatures above 40°C , the current must be further derated to prevent damage.

Pulse Operation: Shunts that do not need continuous operation and are only exposed to intermittent pulses can be operated at levels above their rated current for short periods of times. Pulses are limited to the maximum temperature of the blades not exceeding 145°C (125°C recommended). Many variables such as ambient temperature, cross section of the current carrying conductors, and pulse duration make calculating exact values difficult. Shunt size will need to be validated by customer for pulse current and duty cycle on a case by case basis.

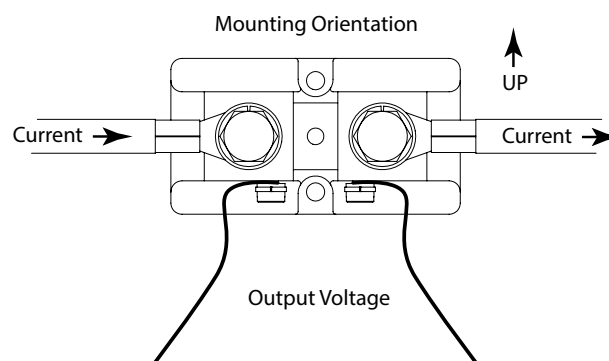

Datenblatt für Präzisionswiderstände

Shunt (Vollmetall-Widerstand)

Serie SMB

Bestellschlüssel						
Beschreibung		Auswahl: Standard=schwarz, mögliche Optionen=grau/kursiv				
Serie:	SMB					
Bauform 1		1				
Nennstrom:						
5 A			A5			
10 A			A10			
15 A			A15			
20 A			A20			
30 A			A30			
50 A			A50			
75 A			A75			
80 A			A80			
85 A			A85			
100 A			A100			
150 A			A150			
Bauform 2		2				
Nennstrom:						
170 A			A170			
200 A			A200			
250 A			A250			
300 A			A300			
400 A			A400			
450 A			A450			
500 A			A500			
600 A			A600			
Bauform 3		3				
Nennstrom:						
800 A			A800			
1000 A			A1000			
1200 A			A1200			
Spannungstoleranz						
±0,25%				V0,25%		
<i>Optional ±0,1%</i>				<i>V0,1%</i>		
Nennleistung:						
50 mV					mV50	
100 mV					mV100	
<i>Optional xy mV</i>					<i>mV...</i>	
Bodenplatte:						
Mit Bodenplatte						-
<i>Optional ohne Bodenplatte</i>						WO

Bestellbeispiel	Serie	Bauform	Nennstrom	Spannungstoleranz	Nennleistung	Bodenplatte
Auswahl	SMB	3	800 Ampere	±0,25%	50 mV	Mit
Schlüssel	SMB	3	A800	V0,25%	mV50	-

Technische Zeichnung

SMB1

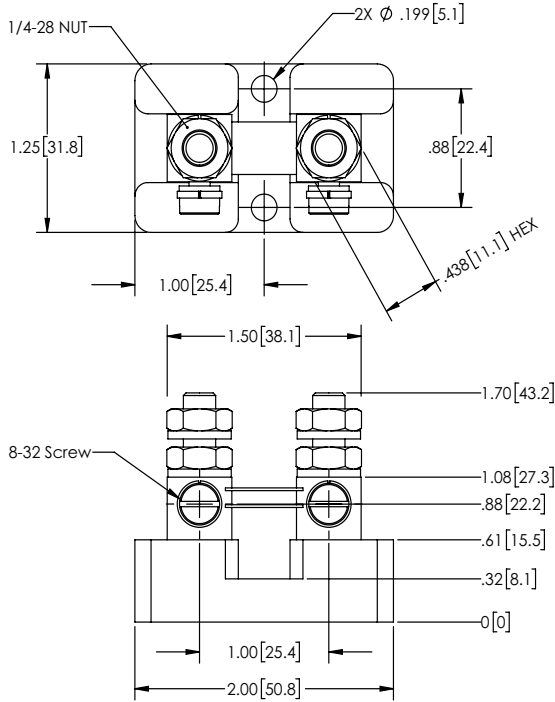

SMB2

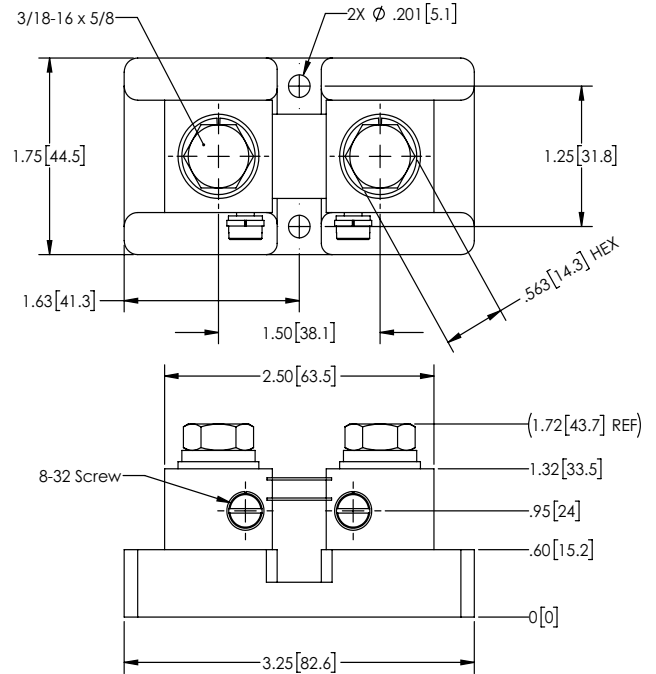

SMB3

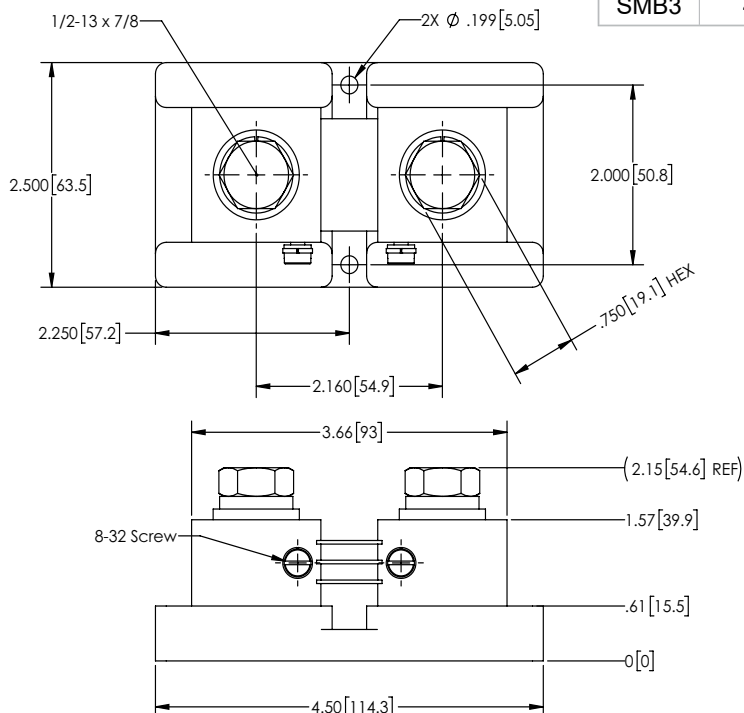

Type	Fastener Torque	Mass	Fastener Torque 8-32 Output
SMB1	4,3 ±0,2 Nm	0,1 kg	1,65 ±0,05 Nm
SMB2	19,5 ±0,5 Nm	0,3 kg	
SMB3	41,5 ±6,5 Nm	0,9 kg	