

Datenblatt für Präzisionswiderstände

Shunt Widerstand

Serie SMA



- Manganin - Shunt-Widerstand
- DC Strommesswiderstand
- Belastbar von 1A bis 500A
- Ausgang 50mV, 100mV oder kundenspezifisch
- Spannungstoleranz von $\pm 0,1\%$

Für Netzteile, Stromwandler, Strommessung u.v.m.

Elektrische Spezifikation

Nennleistung	50 mV, 100 mV, kundenspezifisch
Spannungstoleranz	$\pm 0,1\%$
Nennstrom	1...500 A
TK-Wert (ppm/°C)	± 15 ppm/°C
Arbeitstemperaturbereich (max.)	-30..+70°C
Lagertemperaturbereich	-55..+80°C

Mechanische Spezifikation

Widerstandstechnologie / -material	Vollmetall / Manganin
Gehäusematerial	Kupfer / Bakelite
Anschlüsse	Radial Kupfer

Nennbelastbarkeit in Ampere	Betriebs-Belastbarkeit in Ampere	Widerstandswert @ 50 mV in mΩ	Widerstandswert @ 100 mV in mΩ
1	0,667	50	100
2	1,33	25	50
5	3,33	10	20
10	6,67	5	10
20	13,33	2,5	5
50	33,33	1	2
100	66,67	0,5	1
150	100	0,333	0,667
200	133,33	0,25	0,5
250	166,67	0,2	0,4
300	200	0,167	0,333
400	266,67	0,125	0,25
500	333,33	0,1	0,2

Leistungsminderungskurve

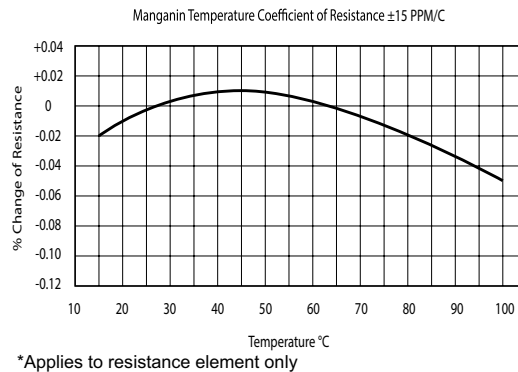

Hinweise

Mounting: Shunts should be mounted with manganin resistive blades in a vertical position in order to promote the free convectional flow of air. If vertical mounting is not practical, forced air cooling or adding heat sinks to the blocks can reduce the operating temperature. The manganin blades must never exceed $+145^{\circ}\text{C}$, otherwise permanent resistance change may occur.

When current of 100A or greater is passing through the shunt, the major portion of heat generated is dissipated by conduction through the shunt terminal blocks into the connecting buss bar or cable. Therefore it is necessary to insure that good contact is made between the shunt terminal blocks and the conductor terminals and that the conductors have adequate cross section to keep the temperature of the shunt from exceeding 145°C (125°C recommended).

If the shunt is mounted in an enclosure, care must be taken to ensure adequate cooling. If the power density is greater than 1/4 watt per square inch of the enclosure surface for all enclosed devices, additional cooling must be supplied in the form of air vents or fans.

Shunts also must be installed in a way that protects them from thermal expansion forces produced from buss bar or short-circuit forces. Flexible wiring may be required in high pulse current, high vibration, or high temperature applications. Where possible, all shunts should be mounted on the ground side of the circuit. For circuits above 750VDC, shunts must be mounted on the ground side due to the dielectric strength of the shunt base.

Operating Current Derating: For continuous operation, it is recommended that shunts are not run at more than two thirds (2/3) the rated current under normal conditions per IEEE standards for DC instrument shunts. At ambient temperatures above 40°C , the current must be further derated to prevent damage.

Pulse Operation: Shunts that do not need continuous operation and are only exposed to intermittent pulses can be operated at levels above their rated current for short periods of times. Pulses are limited to the maximum temperature of the blades not exceeding 145°C (125°C recommended). Many variables such as ambient temperature, cross section of the current carrying conductors, and pulse duration make calculating exact values difficult. Shunt size will need to be validated by customer for pulse current and duty cycle on a case by case basis.

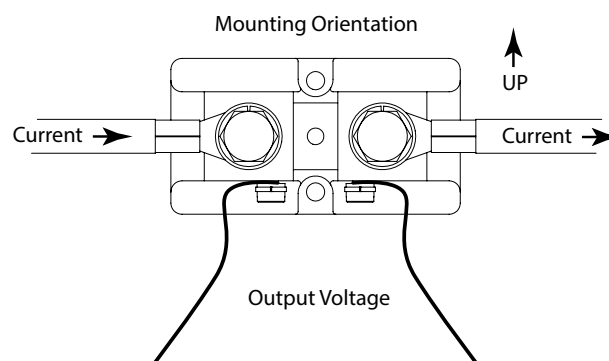

Datenblatt für Präzisionswiderstände

Shunt Widerstand

Serie SMA

Bestellschlüssel

Beschreibung		Auswahl: Standard=schwarz, mögliche Optionen=grau/kursiv			
Serie:	SMA				
Nennstrom:					
1 A		A1			
2 A		A2			
5 A		A5			
10 A		A10			
20 A		A20			
50 A		A50			
100 A		A100			
150 A		A150			
200 A		A200			
250 A		A250			
300 A		A300			
400 A		A400			
500 A		A500			
Spannungstoleranz ±0,1%			V0,1%		
Nennleistung: 50 mV 100 mV <i>Optional xy mV</i>				mV50 mV100 mV...	

Bestellbeispiel	Serie	Nennstrom	Spannungstoleranz	Nennleistung
Auswahl	SMA	500 Ampere	±0,1%	50 mV
Schlüssel	SMA	A500	V0,1%	mV50

Technische Zeichnung

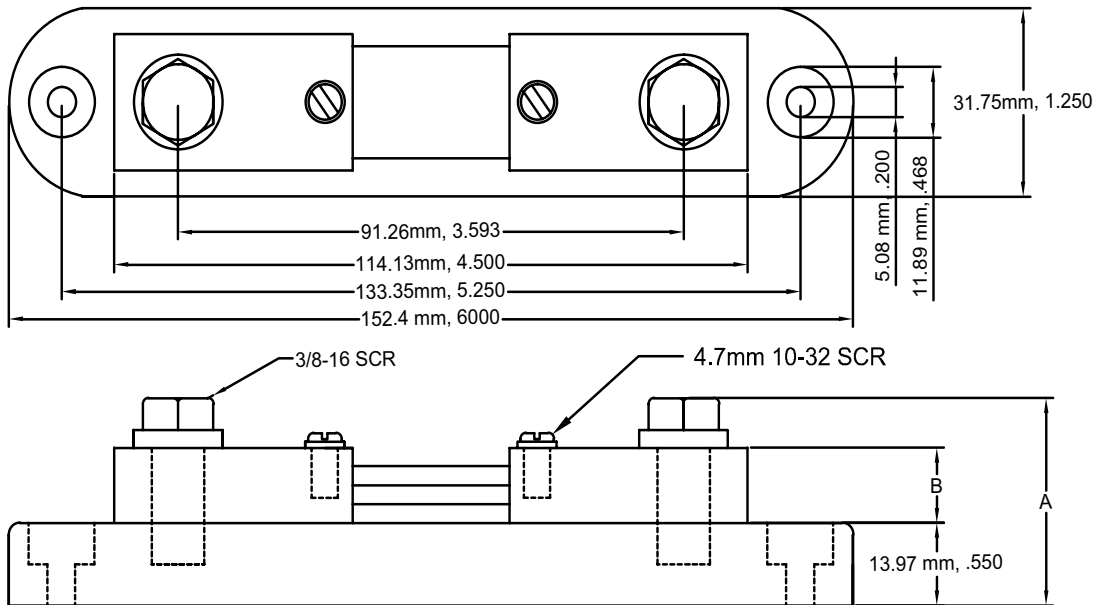

Ampere	50 mV output		100 mV output	
	A	B	A	B
1	35,05	12,70	35,05	12,70
2	35,05	12,70	35,05	12,70
5	35,05	12,70	35,05	12,70
10	35,05	12,70	35,05	12,70
20	35,05	12,70	35,05	12,70
50	35,05	12,70	35,05	12,70
100	35,05	12,70	35,05	12,70
150	35,05	12,70	35,05	12,70
200	35,05	12,70	35,05	12,70
250	41,40	19,05	35,05	12,70
300	41,40	19,05	35,05	12,70
400	41,40	19,05	41,40	19,05
500	41,40	19,05	41,40	19,05