

# ACW SERIES

- ▶ Direct drive brushless motor
- ▶ Fully integrated with encoder and bearing
- ▶ No cogging torque
- ▶ Precise homing through index pulse
- ▶ Large centre hole
- ▶ Low profile



TDS Precision Products GmbH  
Industriestrasse 1a  
CH-8157 Dielsdorf

T + 41 44 885 30 80  
info@tds-pp.com  
www.tds-pp.com

## ACW120

ACW120			
Performance Parameters	Symbol	Unit	Parallel
Continuous Torque @100°C	T <sub>cn</sub>	Nm	0.6
Peak Torque	T <sub>pk</sub>	Nm	2.1
Torque Constant ±10%	K <sub>t</sub>	Nm/Arms	0.14
Back EMF Constant ±10%	K <sub>e</sub>	Vpeak/rpm	0.012
Motor Constant @25°C	K <sub>m</sub>	Nm/Sqrt(W)	0.10
Resistance (L-L) @25°C ±10%	R <sub>25</sub>	Ω	1.43
Inductance (L-L) ±20%	L	mH	0.47
Electrical Time Constant	τ <sub>e</sub>	ms	0.33
Continuous Current @100°C	I <sub>cn</sub>	Arms	4.6
Peak Current	I <sub>pk</sub>	Arms	16.1
Continuous Power Dissipation @100°C	P <sub>cn</sub>	W	58.5
Max. Coil Temperature	t <sub>max</sub>	°C	100
Thermal Dissipation Constant	K <sub>thn</sub>	W/°C	0.78
Max. Bus Voltage	U <sub>bus</sub>	Vdc	330.0
Pole Number	2P	-	16
Max. Speed For Standard Axial/Radial Runout @230V AC	Ω <sub>max</sub>	rpm	400
Max. Speed For Optional Axial/Radial Runout (P10, P5) @230V AC	Ω <sub>max</sub>	rpm	120
Mechanical Parameters			
Overall Mass	m <sub>n</sub>	kg	2.0
Rotor Inertia	J <sub>r</sub>	kg.m <sup>2</sup>	6.584E-04
Axial Runout	-	μm	15 (10,5)
Radial Runout	-	μm	15 (10,5)
Max. Axial Load (Upright Mounting)	-	N	150.0
Max. Axial Load (Inverted / Wall Mounting)	-	N	15.0
Max. Moment Load (Upright Mounting)	-	Nm	14.7
Max. Moment Load (Inverted / Wall Mounting)	-	Nm	1.47
Encoder Parameters			
ABI Optical Incremental Encoder (SIN/COS)	-	lines / rev	3934
ABI Optical Incremental Encoder (80x)	-	counts / rev	314720
ABI Optical Incremental Encoder (160x)	-	counts / rev	629,440
ABI Optical Incremental Encoder (400x)	-	counts / rev	1,573,600
Accuracy after Error Mapping	-	arc sec	+/-8
Repeatability	-	arc sec	+/-4
Other Information			
Insulation Class	Class B (130°C)		
Protection Grade	IP40		
Compliance with Global Standards	RoHS, CE		
Ambient Temperature	Operation	0°C to 40°C (non-freezing)	
	Storage	-15°C to 70°C (non-freezing)	
Ambient Humidity	Operation	10%RH to 80%RH (non-condensing)	
	Storage	10%RH to 90%RH (non-condensing)	
Recommended Ambience	Indoor (no direct sunlight); No corrosive gas, inflammable gas, oil mist or dust.		

- ① Measurement is taken at ambient temperature 25°C. Value depends on the thermal environment.
  - ② Resistance is measured by DC current with standard 3 m cable.
  - ③ Inductance is measured by current frequency of 1 kHz.
  - ④ The value is based on ABI optical SIN/COS encoder (4096x interpolation) under max. bus voltage.
  - ⑤ The runout value in parenthesis is optional.
  - ⑥ Please refer to the illustration for different mountings.
  - ⑦ Based on ABI optical SIN/COS encoder (4096x interpolation) with P5 runout.
- The contents of datasheet are subjected to change without prior notice.

### Dimension

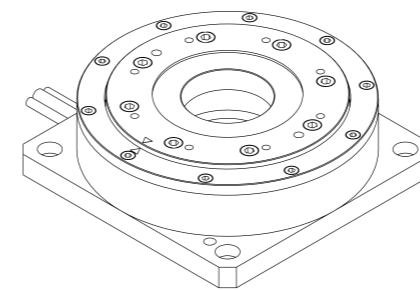

- Note:
- ① 37mm diameter through hole
  - ② Shaded area, mounting surface

### Torque-Speed Curve

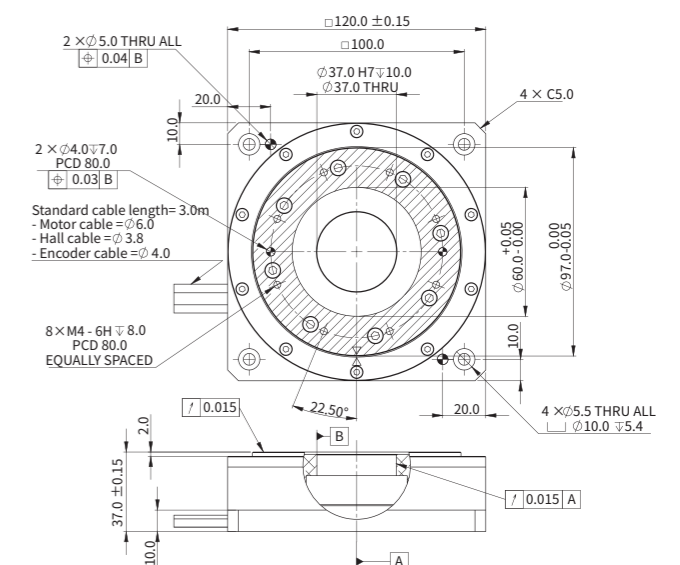
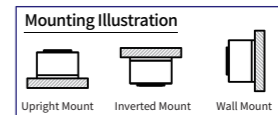
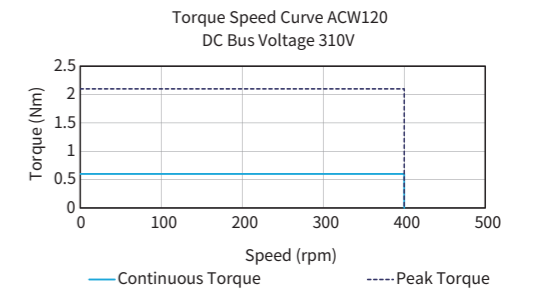

ACW170

ACW170			
Performance Parameters	Symbol	Unit	Parallel
Continuous Torque @100°C	T <sub>cn</sub>	Nm	2.8
Peak Torque	T <sub>pk</sub>	Nm	11.9
Torque Constant ±10%	K <sub>t</sub>	Nm/Arms	0.66
Back EMF Constant ±10%	K <sub>e</sub>	Vpeak/rpm	0.056
Motor Constant @25°C	K <sub>m</sub>	Nm/Sqrt(W)	0.32
Resistance (L-L) @25°C ±10%	R <sub>25</sub>	Ω	2.76
Inductance (L-L) ±20%	L	mH	1.65
Electrical Time Constant	τ <sub>e</sub>	ms	0.60
Continuous Current @100°C	I <sub>cn</sub>	Arms	4.2
Peak Current	I <sub>pk</sub>	Arms	14.7
Continuous Power Dissipation @100°C	P <sub>cn</sub>	W	94.1
Max. Coil Temperature	t <sub>max</sub>	°C	100
Thermal Dissipation Constant	K <sub>thn</sub>	W/°C	1.26
Max. Bus Voltage	U <sub>bus</sub>	Vdc	330.0
Pole Number	2P	-	16
Max. Speed For Standard Axial/Radial Runout @230V AC	Ω <sub>max</sub>	rpm	250
Max. Speed For Optional Axial/Radial Runout (P10, P5) @230V AC	Ω <sub>max</sub>	rpm	120

Mechanical Parameters			
Overall Mass	m <sub>n</sub>	kg	3.7
Rotor Inertia	J <sub>r</sub>	kg.m <sup>2</sup>	2.020E-03
Axial Runout	-	μm	18 (10,5)
Radial Runout	-	μm	18 (10,5)
Max. Axial Load (Upright Mounting)	-	N	230.0
Max. Axial Load (Inverted / Wall Mounting)	-	N	23.0
Max. Moment Load (Upright Mounting)	-	Nm	31.7
Max. Moment Load (Inverted / Wall Mounting)	-	Nm	3.17

Encoder Parameters			
ABI Optical Incremental Encoder (SIN/COS)	-	lines / rev	5560
ABI Optical Incremental Encoder (80x)	-	counts / rev	444800
ABI Optical Incremental Encoder (160x)	-	counts / rev	889,600
ABI Optical Incremental Encoder (400x)	-	counts / rev	2,224,000
Accuracy after Error Mapping	-	arc sec	+/-6
Repeatability	-	arc sec	+/-3

Other Information			
Insulation Class	Class B (130°C)		
Protection Grade	IP40		
Compliance with Global Standards	RoHS, CE		
Ambient Temperature	Operation	0°C to 40°C (non-freezing)	
	Storage	-15°C to 70°C (non-freezing)	
Ambient Humidity	Operation	10%RH to 80%RH (non-condensing)	
	Storage	10%RH to 90%RH (non-condensing)	
Recommended Ambience	Indoor (no direct sunlight); No corrosive gas, inflammable gas, oil mist or dust.		

- ① Measurement is taken at ambient temperature 25°C. Value depends on the thermal environment.
  - ② Resistance is measured by DC current with standard 3 m cable.
  - ③ Inductance is measured by current frequency of 1 kHz.
  - ④ The value is based on ABI optical SIN/COS encoder (4096x interpolation) under max. bus voltage.
  - ⑤ The runout value in parenthesis is optional.
  - ⑥ Please refer to the illustration for different mountings.
  - ⑦ Based on ABI optical SIN/COS encoder (4096x interpolation) with P5 runout.
- The contents of datasheet are subjected to change without prior notice.

Dimension

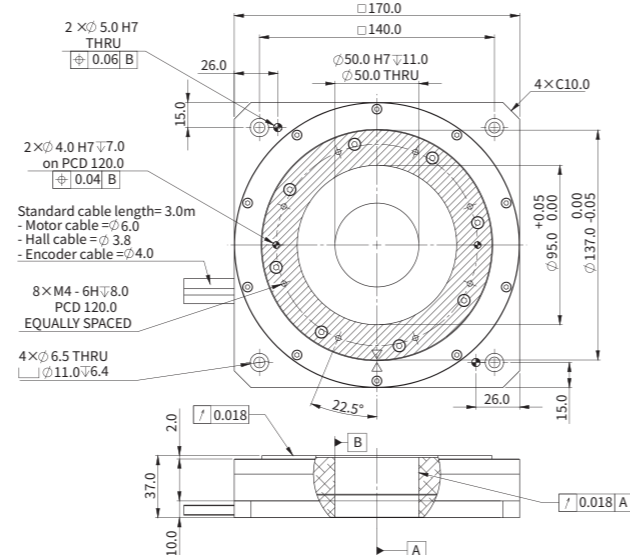
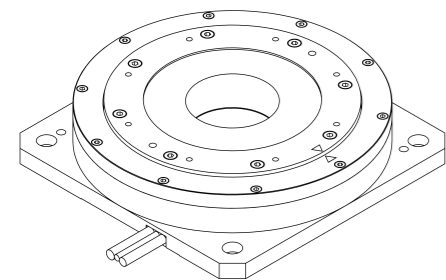

- ① 50mm diameter through hole
- ② Shaded area, mounting surface

Torque-Speed Curve

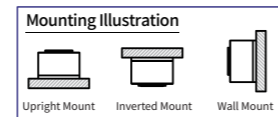
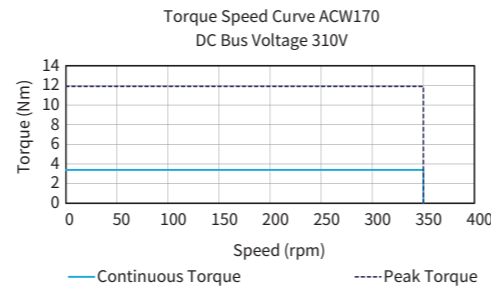

ACW220

ACW220			
Performance Parameters	Symbol	Unit	Parallel
Continuous Torque @100°C	T <sub>cn</sub>	Nm	7.4
Peak Torque	T <sub>pk</sub>	Nm	35.9
Torque Constant ±10%	K <sub>t</sub>	Nm/Arms	1.95
Back EMF Constant ±10%	K <sub>e</sub>	Vpeak/rpm	0.167
Motor Constant @25°C	K <sub>m</sub>	Nm/Sqrt(W)	0.71
Resistance (L-L) @25°C ±10%	R <sub>25</sub>	Ω	5.06
Inductance (L-L) ±20%	L	mH	4.72
Electrical Time Constant	τ <sub>e</sub>	ms	0.93
Continuous Current @100°C	I <sub>cn</sub>	Arms	3.8
Peak Current	I <sub>pk</sub>	Arms	13.3
Continuous Power Dissipation @100°C	P <sub>cn</sub>	W	141.3
Max. Coil Temperature	t <sub>max</sub>	°C	100
Thermal Dissipation Constant	K <sub>thn</sub>	W/°C	1.88
Max. Bus Voltage	U <sub>bus</sub>	Vdc	330.0
Pole Number	2P	-	16
Max. Speed For Standard Axial/Radial Runout @230V AC	Ω <sub>max</sub>	rpm	190
Max. Speed For Optional Axial/Radial Runout (P10, P5) @230V AC	Ω <sub>max</sub>	rpm	120

Mechanical Parameters			
Overall Mass	m <sub>n</sub>	kg	7.0
Rotor Inertia	J <sub>r</sub>	kg.m <sup>2</sup>	8.354E-03
Axial Runout	-	μm	18 (10,5)
Radial Runout	-	μm	18 (10,5)
Max. Axial Load (Upright Mounting)	-	N	300.0
Max. Axial Load (Inverted / Wall Mounting)	-	N	30.0
Max. Moment Load (Upright Mounting)	-	Nm	55.2
Max. Moment Load (Inverted / Wall Mounting)	-	Nm	5.52

Encoder Parameters			
ABI Optical Incremental Encoder (SIN/COS)	-	lines / rev	7500
ABI Optical Incremental Encoder (80x)	-	counts / rev	600000
ABI Optical Incremental Encoder (160x)	-	counts / rev	1,200,000
ABI Optical Incremental Encoder (400x)	-	counts / rev	3,000,000
Accuracy after Error Mapping	-	arc sec	+/-6
Repeatability	-	arc sec	+/-3

Other Information			
Insulation Class	Class B (130°C)		
Protection Grade	IP40		
Compliance with Global Standards	RoHS, CE		
Ambient Temperature	Operation	0°C to 40°C (non-freezing)	
	Storage	-15°C to 70°C (non-freezing)	
Ambient Humidity	Operation	10%RH to 80%RH (non-condensing)	
	Storage	10%RH to 90%RH (non-condensing)	
Recommended Ambience	Indoor (no direct sunlight); No corrosive gas, inflammable gas, oil mist or dust.		

- ① Measurement is taken at ambient temperature 25°C. Value depends on the thermal environment.
  - ② Resistance is measured by DC current with standard 3 m cable.
  - ③ Inductance is measured by current frequency of 1 kHz.
  - ④ The value is based on ABI optical SIN/COS encoder (4096x interpolation) under max. bus voltage.
  - ⑤ The runout value in parenthesis is optional.
  - ⑥ Please refer to the illustration for different mountings.
  - ⑦ Based on ABI optical SIN/COS encoder (4096x interpolation) with P5 runout.
- The contents of datasheet are subjected to change without prior notice.

Dimension

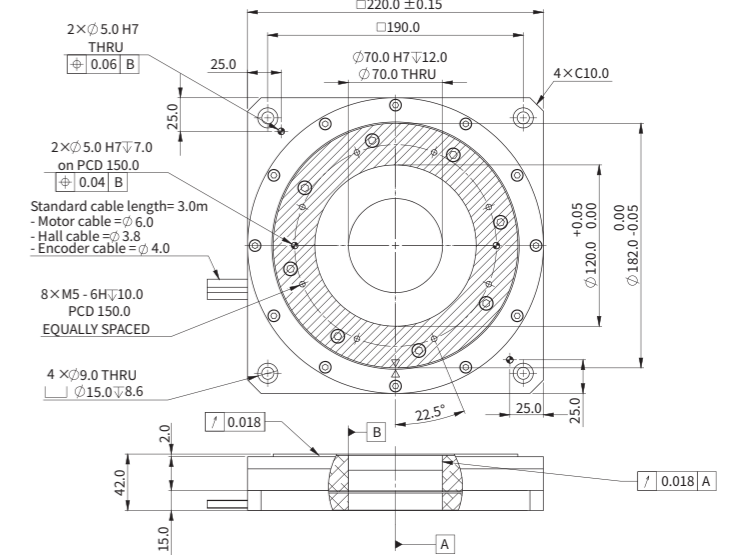
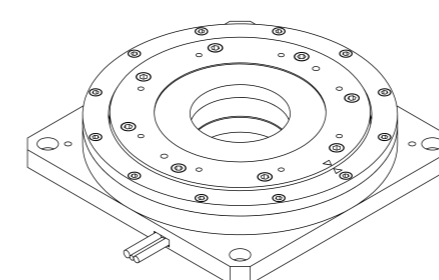

- ① 70mm diameter through hole
- ② Shaded area, mounting surface

## Motor Cable Connection Diagram

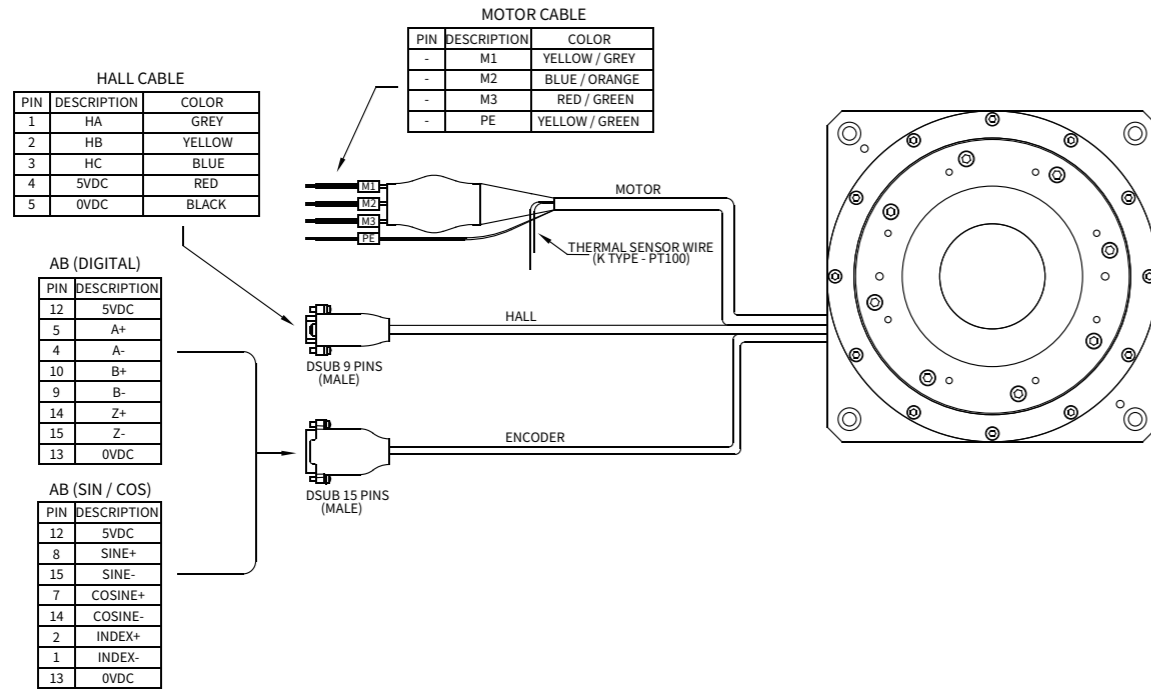

## Part Numbering

**ACW170-37-P-K-H9D-3.0-FB-AB-5560-SINCOS-P18**

Motor Model:

ACW120-37  
ACW170-37  
ACW220-42

Winding:

P=Parallel

Thermal Sensor Options:

K=PT100 (RTD)

Hall Cable Options:

H9D / NH

Cable Length (m):

3.0

Runout:

P5  
P10  
P15  
P18

Interpolation Options:

SINCOS / 80X / 160X / 400X

Encoder:

ACW120:AB-3934  
ACW170:AB-5560  
ACW220:AB-7500

Motor Cable Options:

FB

- H9D=With Built-in hall sensor, comes with 9-Pins D-Sub Connector
- NH=Without Built-in Hall Sensor but with Thermal Sensor
- FB=With ferrite bead
- ACW120 / ACW170 / AXW220:P5= Axial Runout 5um, Radial Runout is 5um  
ACW120 / ACW170 / AXW220:P10= Axial Runout 10um, Radial Runout is 10um  
ACW120:P15= Axial Runout 15um, Radial Runout is 15um  
ACW170 / AXW220:P18= Axial Runout 18um, Radial Runout is 18um

