

# Data Sheet for Joysticks

## Finger Joystick

T + 41 44 885 30 80  
info@tds-pp.com  
www.tds-pp.com

## Series 844



- Very robust joystick
- Small installation depth of < 20 mm
- Wide selection of configurations/handles
- Contact-less, wear-free Hall effect technology
- Reliability through redundant Hall sensors (optional)
- Ideally suited for applications with high mechanical demands

The series 844 offers the most mechanical robust finger joysticks in the portfolio and is suited for harsh conditions. The series uses modern Hall effect sensors, and exhibits robust mechanics (max. load 400 N) with up to 10 million lifecycles. A special feature are the Center Detect and Center Tap outputs for non-redundant versions. Moreover, many different handle designs are available.

### Technical Data

Sensor technology	Hall Effect
Supply Voltage*	5.0 ± 0.5 VDC transient free
Voltage in Center Position*	2.5 V
Return to Center Accuracy	±5% of maximum output
Output Impedance	10 Ohm
Impedance	Min. 10 kOhm, > 100 kOhm recommended
Life Cycles	10 Mio. cycles (5 Mio. with 3 axes)
Output Signal	0 to 5 V / 0.5 to 4.5 V (others on request)
Supply Current	<13 mA (2 axes) / <20 mA (3 axes)
Angle of Movement X-, Y-Axis / Z-Axis	36° (±18° from center) / 50° (±25° from center)
Operating Force X-Y-Axis	Breakout force standard typ. 1.3 N (1.0 N and 1.6 N available on request)
Max. vertical Load to Mechanism	400 N
Operating / Storage Temperature	-25 °C to +70 °C / -40 °C to +70 °C
Above Panel Sealing	Up to IP65 (depending on handle configuration)
EMC Emission	EN61000-6-3 CISPR 22:2005 Class B 30 MHz - 11 GHz
EMC Immunity	100 V/m 80 MHz - 2.7 GHz, 1 kHz 80% sine wave modul., EN61000-4-3 (extended)
ESD	EN61000-4-2 (extended) ±8 kV (20 contacts) & ±15 kV (20 air discharges)
Vibration	100 Hz - 200 Hz @ 0.13 g <sup>2</sup> /Hz, total 3.6 g RMS 1h in each of three perp. axes

\*The output voltage is ratiometric to the supply voltage. We therefore suggest to use low-noise, stabilized power supplies.

### Mechanism

The omni-directional mechanism features an extremely robust ball-socket pivot. This construction yields a product that is very resistant to vertical impact, and constantly withstands high pull, push, rotational or horizontal forces.

### Magnetic screening

The 844 series incorporates internal magnetic screening to minimize the effect of external magnetic fields. Nevertheless, we do not recommend mounting or operating the joystick close to strong magnetic fields.

# Data Sheet for Joysticks

Finger Joystick

Series 844

Please contact us for information regarding stock articles, delivery times and minimum order quantities.

## Order Code

Description								
<b>Series</b>	844							
<b>Axes:</b>								
1 Axis		1						
2 Axes		2						
3 Axes		3						
<b>Sealing/Rubber Boot:</b>								
Circular Bezel, below panel mounting			3					
Circular Bezel, drop-in mounting			4					
No Bezel, below panel mounting			1					
Square Bezel, drop-in mounting			2					
<b>Return Mechanism:</b>								
Spring Return				1				
Spring Return with Guided Feel in X & Y				2				
<b>Handles:</b>								
Handle C for 1-2 axes, conical mid-size					C			
Handle E for 1-2 axes, with Pushbutton					E			
Handle I for 3 axes					I			
Handle J for 3 axes, with Pushbutton					J			
Handle A for 1-2 axes, round					A			
Handle F for 1-2 axes, cylindrical, skirted					F			
Handle T for 1-2 axes, cylindrical, Aluminum, with Pushbutton					T			
<b>Limiters:</b>								
Circular						5		
Square						6		
Single Axis, X direction only						1		
Single Axis, Y direction only						2		
X/Y Plus "+"						3		
Square rotated by 45°, "diamond"						4		
<b>Sensor options:</b>								
Standard (single)							S	
Dual Redundant, Parallel Output							P	
Dual Redundant, Inverse Output							I	
PWM							W	
<b>Output Signal:</b>								
0 to 5.0 V								5
0.5 to 4.5 V								4
PWM								-

## For higher quantities or on-going demand, additional options are available

- Customer-specific cables
- Stabilized 3.3 V electronics for in- and output
- Further handle versions
- Customer-specific handles
- Custom deflection/return-to-center force, by stronger or weaker spring

## Cable harness

The joysticks are delivered with standard connection wires (2.5 mm raster, compatible to Molex KK series). For non-redundant versions without pushbutton, a 7-pin connector is delivered. For versions with pushbutton, a 9-pin connector is the default configuration. See the table below for pin configuration.

The wire length is ca. 150 mm. Please contact us for custom cable configurations.

# Data Sheet for Joysticks

## Finger Joystick

Series 844

### Wiring\*\*

Pin	Function	Color
1	Ground	black
2	Center Tap (desc. see below)	green
3	Z-Axis	purple
4	Y-Axis	yellow
5	X-Axis	blue
6	Vsupply	red
7	Center Detect (desc. see below)	orange
8***	Pushbutton	orange
9***	Pushbutton	orange

Orientation / Polarity

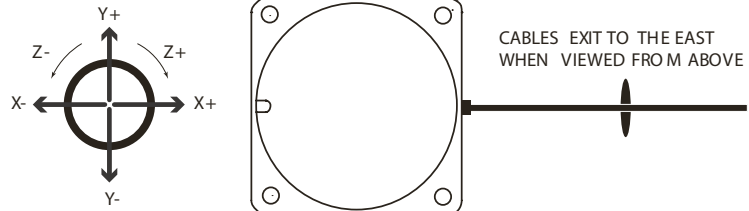

\*\*Valid for standard/single voltage supply. Please contact us for redundant version cable configuration.

\*\*\*Only for versions with pushbutton(s)

### Output impedance

The voltage outputs at the limits and at the center are specified for an infinite load at the outputs (no current flowing). Lower loads than 10 kOhms need to be avoided.

### Center Tap (CT)

The standard electronics (no redundancy) offers a center reference voltage output, that is set to 50% ( $\pm 1\%$ ) of the supply voltage. This output can be used to check the integrity of the power supply. Voltage readings outside the tolerances suggest a problem with the power supply.

Another function of this output is as a reference relative to the center position of the joystick. Measuring the voltage output relative to the CT output, rather than relative to ground, eliminates inaccuracies caused by the power supply.

### Center Detect (CD)

The standard electronics (no redundancy) offers a center detect output, which is 0 V if the joystick is inactive, but switches to high (5 V if operated with 5 V power supply) only if the joystick is operated.

In the internal electronics, this output is pulled high by a 2K2 resistor and is decoupled by a 100 nF capacitor to 0 V.

This output is designed for use in applications requiring an enable/disable signal that is separate from the main wipers. We do not recommend to use this as a safety feature or a method of "person-present" detection (deadman).

### Spring return

The standard force required for the deflection is 1.3 N. On request, also weaker (1.0 N) or stronger springs can be selected (1.6 N).



"Guided feel" still allows the joystick handle to be deflected omni-directionally, but as the operation force needed for the main axes is slightly below the force needed for diagonal deflection the resulting impression is that of a "guided movement".

### Limiters



Square - Option 6



Single Axis X - Option 1



Circular - Option 5



Single Axis Y - Option 2



Square rotated by 45°, "Diamond" - Option 4



X/Y Plus "+" - Option 3

# Data Sheet for Joysticks

Finger Joystick

Series 844

## Technical Drawing

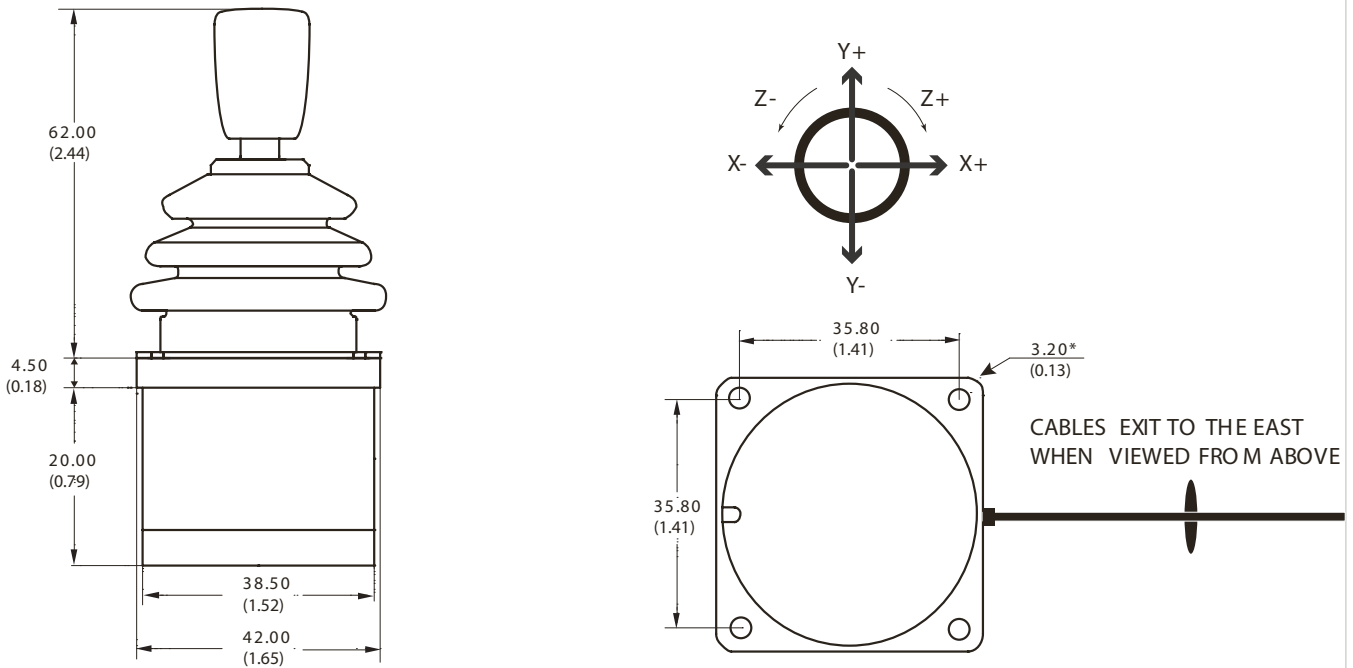

Dimensions are in mm/(inch)

## Handle Types (Part 1)

### Standard Handles

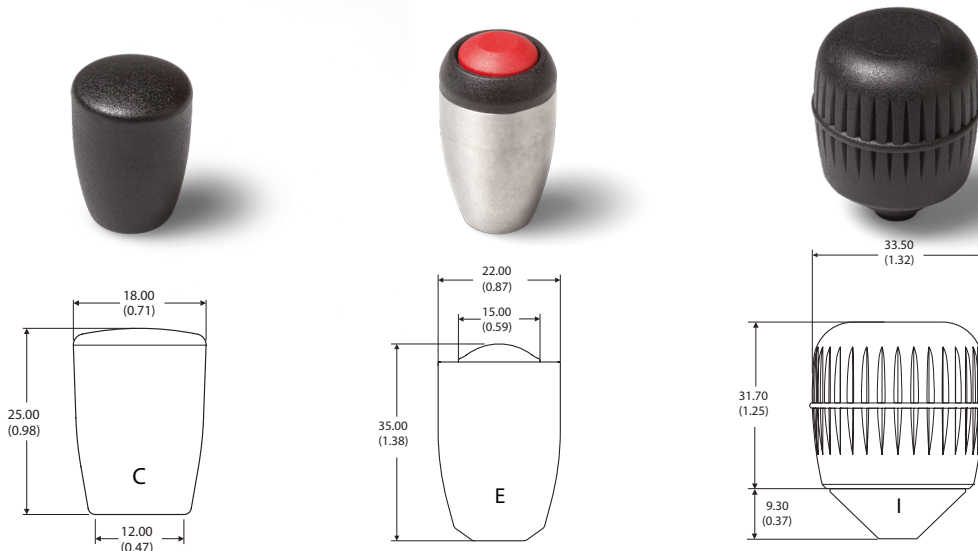

Handles	C	E	I
<b>Material</b>	Nylon	Aluminium	Nylon
<b>Finish</b>	Sparked Matt	Anodised	Sparked Matt
<b>Standard color</b>	Black	Black	Black
<b>Other colors</b>	upon request	not available	upon request
<b>Notes</b>	1-2 Axes	1-2 Axes with Pushbutton	3 Axes

Continued on next page

# Data Sheet for Joysticks

Finger Joystick

Series 844

## Handle Types (Part 2)

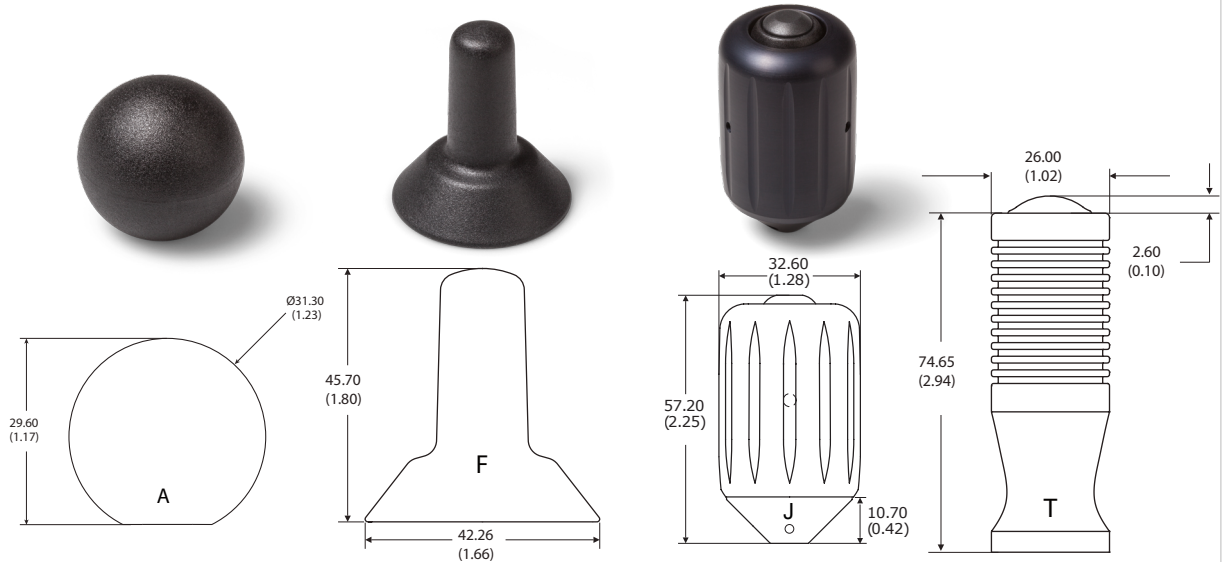

Handles	A	F	J	T
Material	Nylon	Nylon	Aluminium	Aluminium
Finish	Sparked Matt	Sparked Matt	Anodized	Anodized
Standard color	Black	Black	Black	Black
Other colors	not available	not available	not available	not available
Notes	1-2 Axes	1-2 Axes	3 Axes with Pushbutton	1-2 Axes with Pushbutton

Further handle versions available upon request:

All dimensions in mm (inches)



### Mounting Options

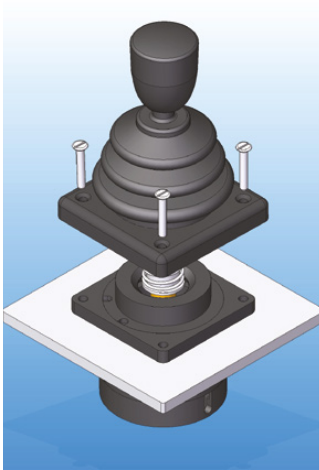

#### Drop-in of Joystick into panel cut-out.

For panel thickness < 3 mm, M3 x 16 countersunk machine screw are recommended. Also available with circular bezel.

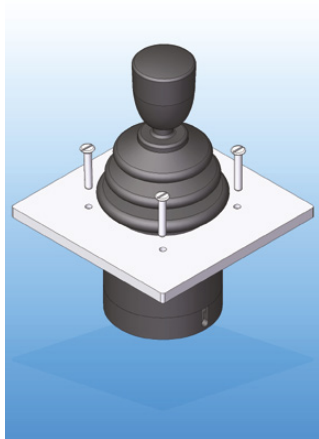
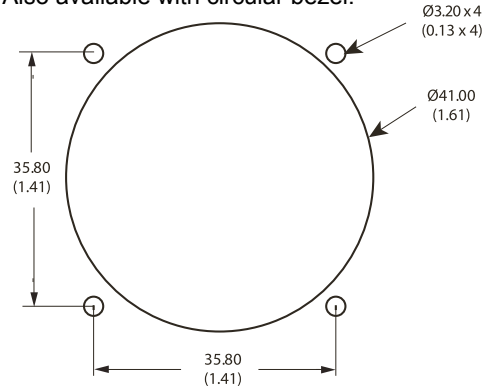

#### Mounting of Joystick from beneath the panel.

No bezel needed. M3 machine screws recommended.

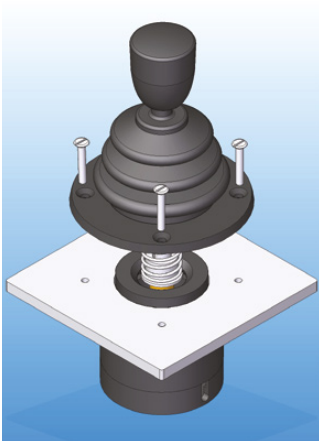
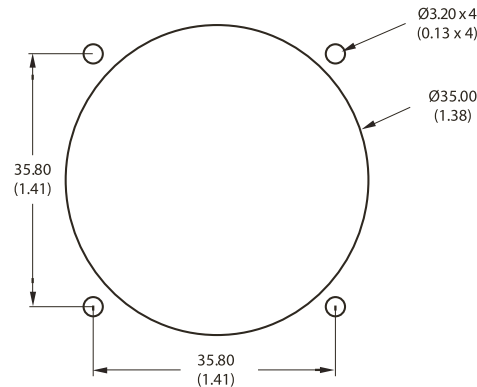

#### Mounting with circular bezel from beneath the panel.

Base of boot must be brought through panel cut-out and held in place with the circular bezel. For panel thickness < 3 mm, M3 x 16 countersunk machine screw are recommended.

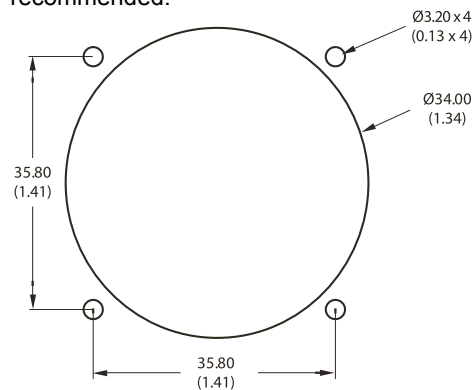

All Dimensions in mm