

CATALOG CODE	DYNAMIC TORQUE			
	FORWARD		REVERSE	
	Nm	LB-IN	Nm	LB-IN
vTILT-100-3.0-D-XX	3 ± 0.75	26.6 ± 6.7	1.88 ± 0.66	16.6 ± 5.9
vTILT-100-4.0-D-XX	4 ± 0.8	35.4 ± 7.1	2.50 ± 0.75	22.1 ± 6.7
vTILT-100-5.0-D-XX	5 ± 1.0	44.3 ± 8.9	3.13 ± 0.94	27.7 ± 8.4
vTILT-100-6.0-D-XX	6 ± 1.2	53.1 ± 10.7	3.75 ± 1.13	33.2 ± 10.1
vTILT-100-8.0-D-BK	8 ± 1.6	70.8 ± 14.2	5.00 ± 1.50	44.3 ± 13.4
vTILT-100-5.0-OW-BK	5 ± 1.0	44.3 ± 8.9	0.9 MAX	8.0 MAX
vTILT-100-6.0-OW-BK	6 ± 1.2	53.1 ± 10.7	0.9 MAX	8.0 MAX
vTILT-100-7.0-OW-BK	7 ± 1.4	62.0 ± 12.5	0.9 MAX	8.0 MAX
vTILT-100-8.0-OW-BK	8 ± 1.6	70.8 ± 14.2	0.9 MAX	8.0 MAX

NOTES:

1. STATIC TORQUE IS NORMALLY WITHIN 10% OF DYNAMIC TORQUE
2. LIFE: 20,000 CYCLES MIN. ONE CYCLE CONSISTS OF 90° OPEN AND 90° CLOSED, 5 CYCLES PER MINUTE MAX.
3. COUNTERBORE HOLE PATTERN DESIGNED TO MEET VESA MIS-D, 75/100, C.
4. MATERIAL:
SLEEVE AND BUSHING: ZINC DIE CAST
SHAFT AND TORQUE ELEMENT: HARDENED STEEL
PLATE AND SWIVEL BODY: ENGINEERED PLASTIC
MINERAL OIL BASED LUBRICANT
5. MAXIMUM MONITOR WEIGHT 11.3 Kg (25 LBS).
6. USER MUST DETERMINE FITNESS FOR USE IN APPLICATION.

CATALOG CODE vTILT-100-X.X-XX-XX

STANDARD VESA MOUNTING PATTERN

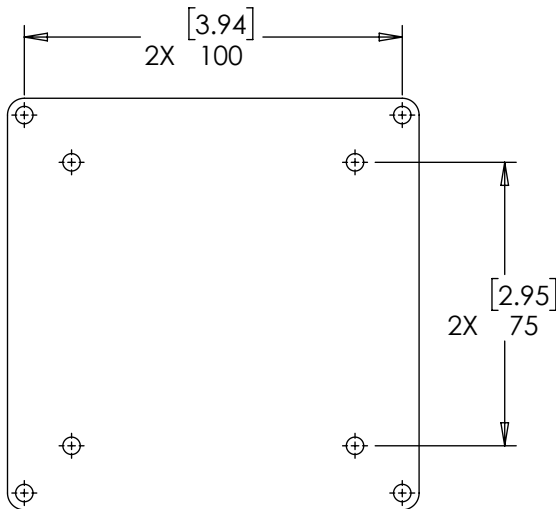

SPECIFICATIONS SUBJECT TO CHANGE.

TORQUE Nm
3.0
4.0
5.0
6.0
7.0
8.0

TYPE
D - DIFFERENTIAL
OW - ONE WAY

COLOR
BK - BLACK
WH - WHITE

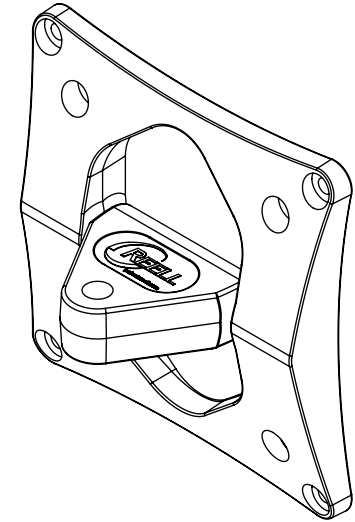

TDS Precision Products GmbH
Industriestrasse 1a
CH-8157 Dielsdorf
T + 41 44 885 30 80
info@tds-pp.com
www.tds-pp.com

INTERPRET PRINT PER ASME Y14.5M-1994
THIS PRINT IS THE CONFIDENTIAL PROPERTY OF REELL PRECISION MFG.
THIRD ANGLE PROJECTION

LEVEL	DESCRIPTION	DRAWN	DATE	APPROVED
DRAWN: HMA	DATE: 22JUN10	PART NO:		
CHECKED: ACT	DATE: 11JAN11	TITLE:		
APPROVED: ACT	DATE: 11JAN11	SALES DRAWING		
REVISED: 15JUN20	DIMS: mm[IN]			
REELL PRECISION MANUFACTURING 1259 WILLOW LAKE BOULEVARD SAINT PAUL, MINNESOTA 55110-5103, USA		DESCRIPTION: vTILT-100		REV: L
SCALE: 1:2		DO NOT SCALE DRAWING		SHEET 1 OF 2

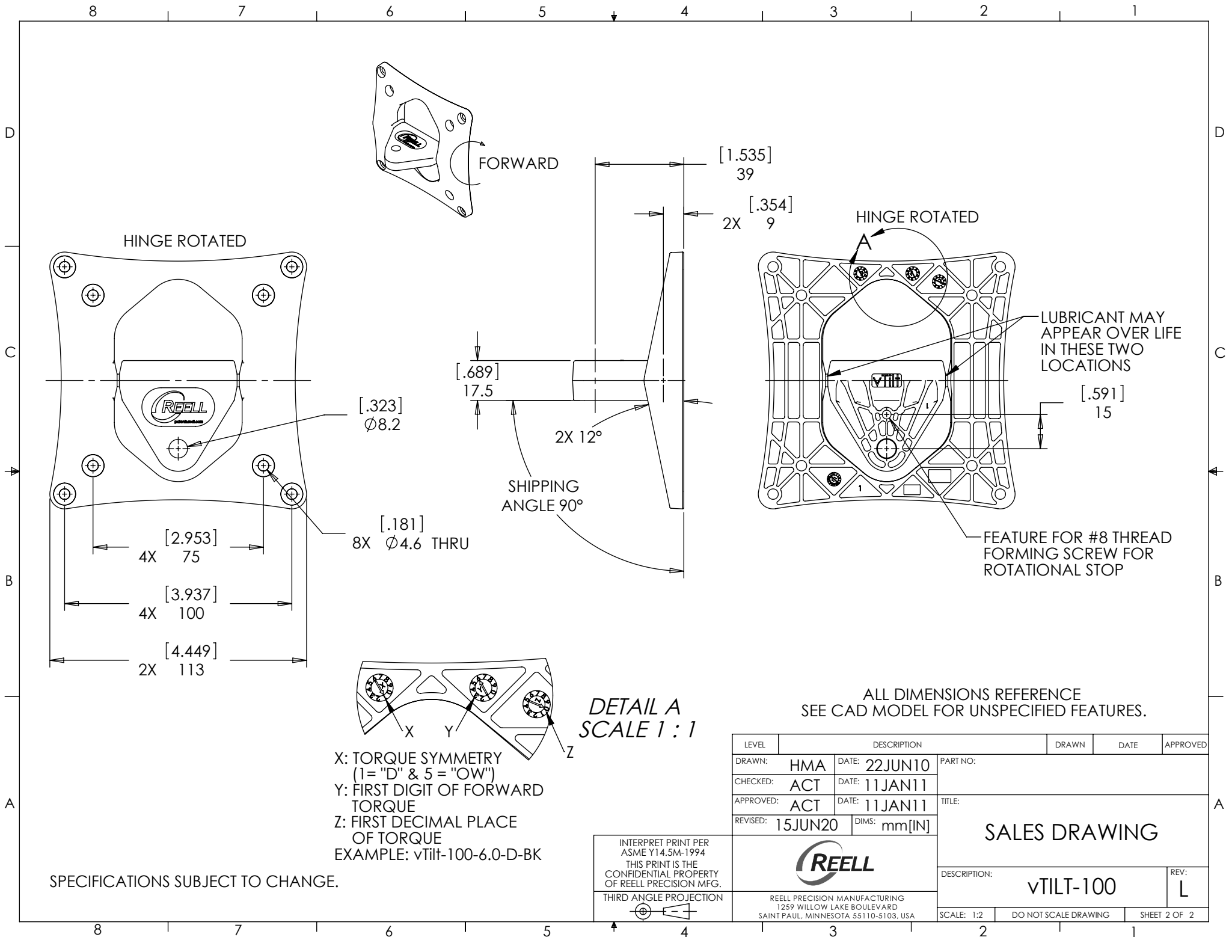

HINGE ROTATED

FORWARD

HINGE ROTATED

LUBRICANT MAY APPEAR OVER LIFE IN THESE TWO LOCATIONS

FEATURE FOR #8 THREAD FORMING SCREW FOR ROTATIONAL STOP

DETAIL A
SCALE 1:1

X: TORQUE SYMMETRY
(1 = "D" & 5 = "OW")
Y: FIRST DIGIT OF FORWARD TORQUE
Z: FIRST DECIMAL PLACE OF TORQUE
EXAMPLE: vTilt-100-6.0-D-BK

SPECIFICATIONS SUBJECT TO CHANGE.

ALL DIMENSIONS REFERENCE
SEE CAD MODEL FOR UNSPECIFIED FEATURES.

LEVEL	DESCRIPTION		DRAWN	DATE	APPROVED
DRAWN:	HMA	DATE: 22JUN10	PART NO:		
CHECKED:	ACT	DATE: 11JAN11	TITLE:		
APPROVED:	ACT	DATE: 11JAN11	SALES DRAWING		
REVISED:	15JUN20	DIMS: mm[IN]			
 REELL PRECISION MANUFACTURING 1259 WILLOW LAKE BOULEVARD SAINT PAUL, MINNESOTA 55110-5103, USA			DESCRIPTION:		REV:
			vTILT-100		L
SCALE: 1:2		DO NOT SCALE DRAWING		SHEET 2 OF 2	

INTERPRET PRINT PER
ASME Y14.5M-1994
THIS PRINT IS THE
CONFIDENTIAL PROPERTY
OF REELL PRECISION MFG.

THIRD ANGLE PROJECTION

