

CATALOG CODE TI-360-X.XX-XX

TORQUE Nm
6.00
8.00
10.0

SHAFT-END TYPE
01 - KNURLED SHAFT
02 - KNURLED ADAPTER
03 - ONE WAY FORWARD
04 - ONE WAY REVERSE
05 - DUAL ENDED KNURLED SHAFT

- NOTES:
1. USER MUST DETERMINE FITNESS FOR USE IN APPLICATION.
 2. ENVIRONMENTAL CONDITIONS: -20°C to 80°C.
 3. PRODUCT TORQUE SPECIFICATION: DYNAMIC TORQUE $\pm 20\%$ OF NOMINAL
 4. LIFE: 25,000 CYCLES. ONE CYCLE CONSISTS OF 120° CW AND 120° CCW AT 10% DUTY CYCLE FOR SPEEDS LESS THAN 100 RPM.
 5. MATERIALS:
PLATED POWDERED METAL HOUSINGS
HARDENED STEEL TORQUE ELEMENT
DIECAST KNURLED ZINC SHAFT END
HARDENED STEEL BEARINGS
STEEL WASHERS
STEEL RETAINING RINGS
MINERAL OIL BASED LUBRICANT
 6. FINISH:
NON-COSMETIC.
 7. TORQUE INSERT DESIGNED FOR USE IN PLASTIC OR METAL. SEE INDIVIDUAL CONFIGURATION DRAWINGS FOR ADDITIONAL DETAIL.
 - [8] TORQUE INSERT DESIGNED TO SUPPORT A MINIMAL AXIAL FORCE IN DIRECTION SHOWN, NOT DESIGNED TO SUPPORT AXIAL FORCE IN THE OPPOSITE DIRECTION.
 9. CUSTOMER IS RESPONSIBLE FOR CHECKING COMPATIBILITY OF REELL LUBRICANTS WITH PLASTICS USED.
 10. OVERALL LENGTH MAY CHANGE DURING SHIPPING.
 11. NUMBER OF TORQUE ELEMENTS MAY VARY.



TDS Precision Products GmbH
Industriestrasse 1a
CH-8157 Dielsdorf

T + 41 44 885 30 80
info@tds-pp.com
www.tds-pp.com

UNLESS SPECIFIED
TOLERANCE ± 0.15
INTERPRET PRINT PER
ASME Y14.5M-1994
THIS PRINT IS THE
CONFIDENTIAL PROPERTY
OF REELL PRECISION MFG.

THIRD ANGLE PROJECTION



LEVEL	DESCRIPTION		DRAWN	DATE	APPROVED
DRAWN:	HMA	DATE: 16APR12	REFERENCE:		
CHECKED:	MPG	DATE: 26APR17	TITLE:		
APPROVED:	MPG	DATE: 26APR17	SALES DRAWING		
REVISED:	23JUN20	DIMS: mm	PART NO: TI-360		
		REV: C		SCALE: 1:1	
REELL PRECISION MANUFACTURING 1259 WILLOW LAKE BOULEVARD SAINT PAUL, MINNESOTA 55110-5103, USA		DO NOT SCALE DRAWING		SHEET 1 OF 10	

FOR PATENTS SEE:
pat.reell.com (PRODUCT CODE: CP10)

SPECIFICATION SUBJECT TO CHANGE

TI-360-X.XX-01 (KNURLED SHAFT)

ALL DIMENSIONS ARE REFERENCE
SEE CAD MODEL FOR UNSPECIFIED FEATURES.

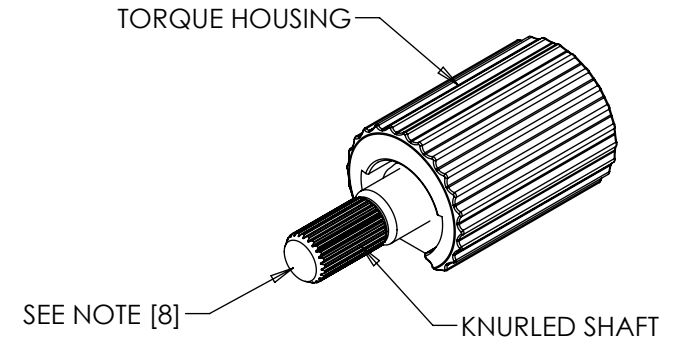
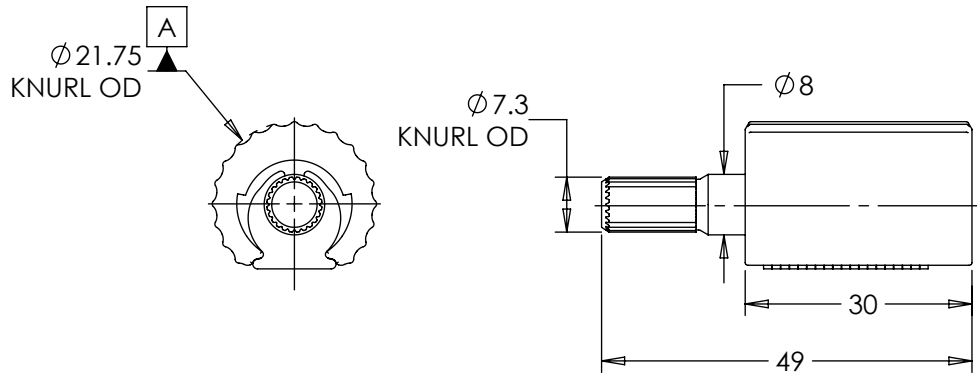

- SEE PAGE 5 FOR INSTALLATION RECOMMENDATIONS.
- INTENDED FOR PRESS FIT INTO METALS. CONTACT REELL FOR OTHER MOUNTING OPTIONS.
- APPROXIMATE WEIGHT: 61.2 GRAMS

TI-360-X.XX-02 (KNURLED ADAPTER)

ALL DIMENSIONS ARE REFERENCE
SEE CAD MODEL FOR UNSPECIFIED FEATURES.

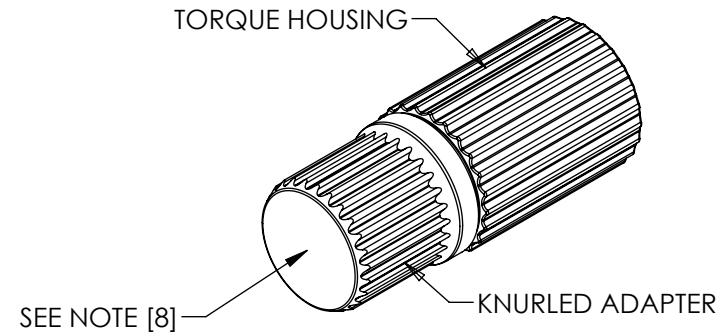
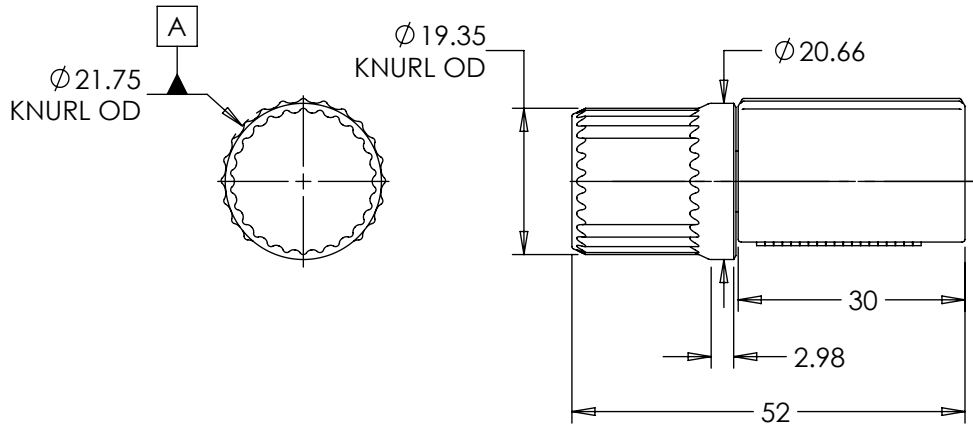

- SEE PAGES 6 AND 7 FOR INSTALLATION RECOMMENDATIONS.
- INTENDED FOR PRESS FIT INTO PLASTICS. CONTACT REELL FOR OTHER MOUNTING OPTIONS.
- APPROXIMATE WEIGHT: 92.6 GRAMS

SPECIFICATION SUBJECT TO CHANGE

LEVEL	DESCRIPTION		DRAWN	DATE	APPROVED
DRAWN:	HMA	DATE: 16APR12	REFERENCE:		
CHECKED:	MPG	DATE: 26APR17	TITLE:		
APPROVED:	MPG	DATE: 26APR17	SALES DRAWING		
REVISED:	23JUN20	DIMS: mm	PART NO: TI-360		REV: C
INTERPRET PRINT PER ASME Y14.5M-1994 THIS PRINT IS THE CONFIDENTIAL PROPERTY OF REELL PRECISION MFG. THIRD ANGLE PROJECTION				REELL PRECISION MANUFACTURING 1259 WILLOW LAKE BOULEVARD SAINT PAUL, MINNESOTA 55110-5103, USA	
SCALE: 1:1		DO NOT SCALE DRAWING		SHEET 2 OF 10	

TI-360-X.XX-03 (ONE WAY FORWARD)

TI-360-X.XX-04 (ONE WAY REVERSE)

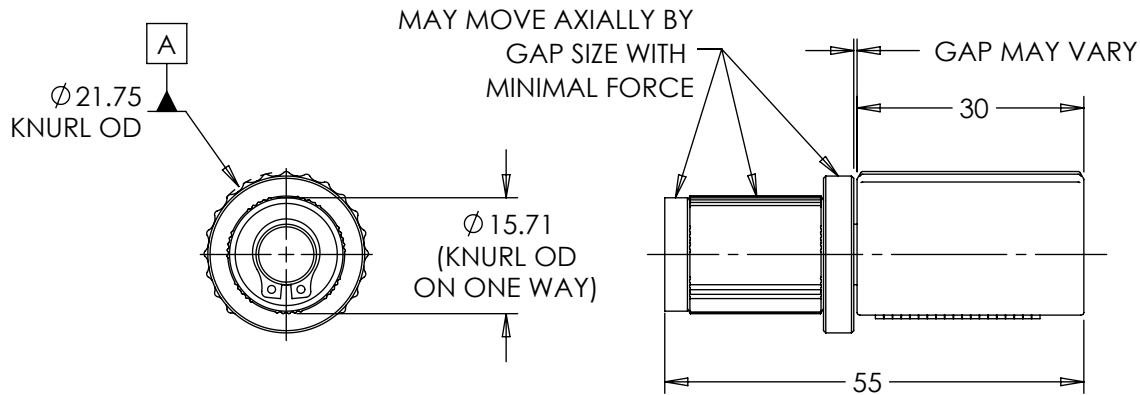
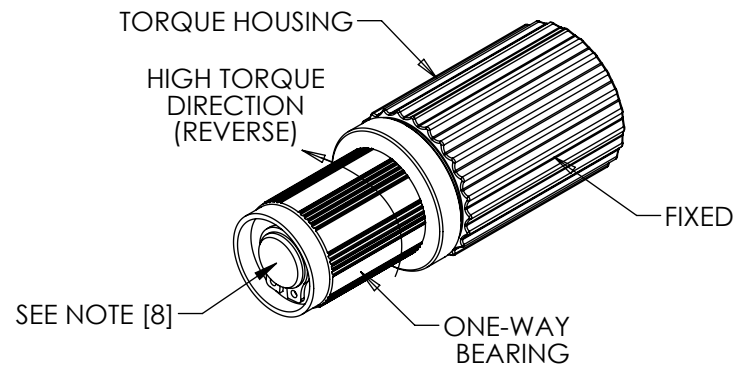
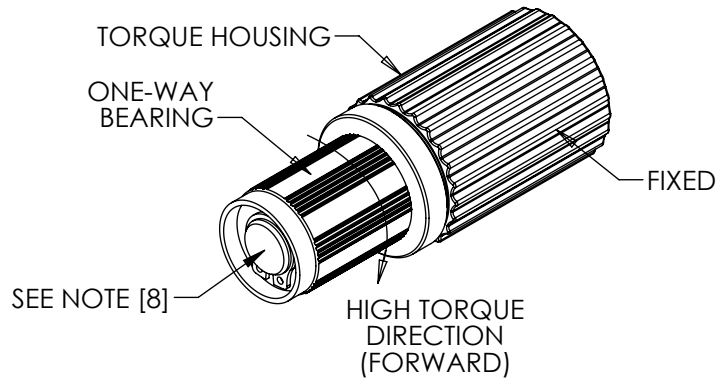

- SEE PAGE 8 FOR INSTALLATION RECOMMENDATIONS.
- INTENDED FOR PRESS FIT INTO METALS. CONTACT REELL FOR OTHER MOUNTING OPTIONS.
- APPROXIMATE WEIGHT: 91.7 GRAMS

TDS Precision Products
TDS Precision Products GmbH
Industriestrasse 1a
CH-8157 Dielsdorf
T + 41 44 885 30 80
info@tds-pp.com
www.tds-pp.com

ALL DIMENSIONS ARE REFERENCE
SEE CAD MODEL FOR UNSPECIFIED FEATURES.

LEVEL	DESCRIPTION	DRAWN	DATE	APPROVED
DRAWN:	HMA	DATE:	16APR12	REFERENCE:
CHECKED:	MPG	DATE:	26APR17	TITLE: SALES DRAWING
APPROVED:	MPG	DATE:	26APR17	
REVISED:	23JUN20	DIMS:	mm	
		PART NO:		REV:
REELL PRECISION MANUFACTURING 1259 WILLOW LAKE BOULEVARD SAINT PAUL, MINNESOTA 55110-5103, USA		TI-360		C
SCALE: 1:1		DO NOT SCALE DRAWING		SHEET 3 OF 10

INTERPRET PRINT PER ASME Y14.5M-1994
THIS PRINT IS THE CONFIDENTIAL PROPERTY OF REELL PRECISION MFG.
THIRD ANGLE PROJECTION

SPECIFICATION SUBJECT TO CHANGE

TI-360-X.XX-05 (DUAL ENDED KNURLED SHAFT)

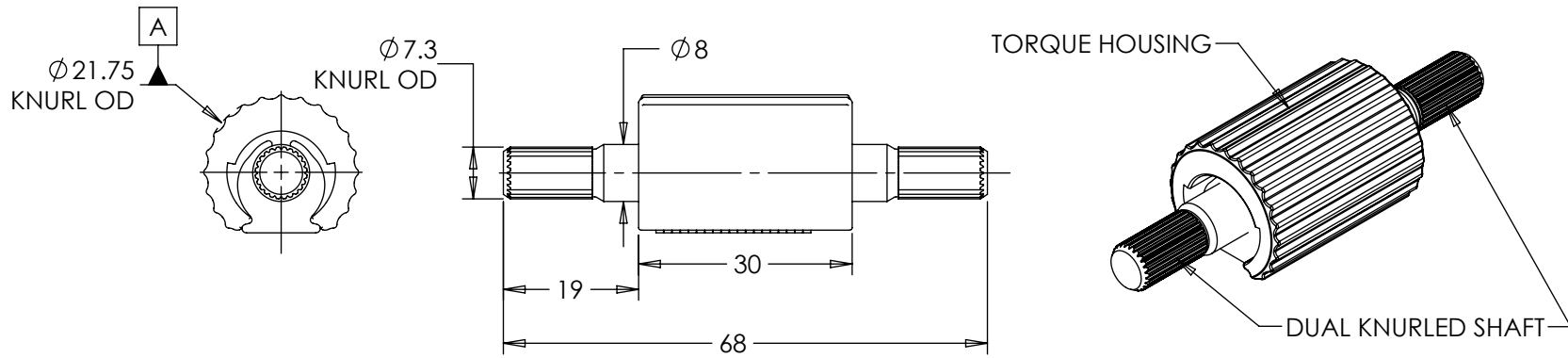

- SEE PAGES 9 AND 10 FOR INSTALLATION RECOMMENDATIONS.
- INTENDED FOR PRESS FIT INTO METALS. CONTACT REELL FOR OTHER MOUNTING OPTIONS.
- APPROXIMATE WEIGHT: 67.5 GRAMS

ALL DIMENSIONS ARE REFERENCE
SEE CAD MODEL FOR UNSPECIFIED FEATURES.

TDS Precision Products
 TDS Precision Products GmbH
 Industriestrasse 1a
 CH-8157 Dielsdorf
 T + 41 44 885 30 80
 info@tds-pp.com
 www.tds-pp.com

INTERPRET PRINT PER
 ASME Y14.5M-1994
 THIS PRINT IS THE
 CONFIDENTIAL PROPERTY
 OF REELL PRECISION MFG.
 THIRD ANGLE PROJECTION

LEVEL	DESCRIPTION	DRAWN	DATE	APPROVED
DRAWN:	HMA	DATE:	16APR12	REFERENCE: TITLE: SALES DRAWING
CHECKED:	MPG	DATE:	26APR17	
APPROVED:	MPG	DATE:	26APR17	
REVISED:	23JUN20	DIMS:	mm	
REELL PRECISION MANUFACTURING 1259 WILLOW LAKE BOULEVARD SAINT PAUL, MINNESOTA 55110-5103, USA		PART NO:		REV:
		TI-360		C
SCALE: 1:1		DO NOT SCALE DRAWING		SHEET 4 OF 10

SPECIFICATION SUBJECT TO CHANGE

TI-360-X.XX-01 CUSTOMER INSTALLATION GEOMETRY

MATERIAL	D1	D2	D3	D4	D5	L1	L2	L3	L4	L5	CF1	CF2	OD1	OD2	WALL	GAP
DIE CAST ZINC	21.5±0.05	22±0.03	8.15±0.03	7.95±0.03	7.15±0.03	33 MIN	3±0.1	3±0.1	3±0.1	16.75 MIN	0.3±0.1 X 45°±5°	0.3±0.1 X 45°±5°	26.75 MIN	14 MIN	2 MIN	(0.3)
DIE CAST ALUMINUM				8.05±0.03	7.2±0.03											
MILD STEEL	21.63 ±0.025			8.05±0.03	7.2±0.03											
WROUGHT ALUMINUM																

INSTALLATION RAM TO CONTACT BOTH TORQUE HOUSING & SHAFT DURING PRESS. MINIMUM RAM DIAMETER OF 21mm.

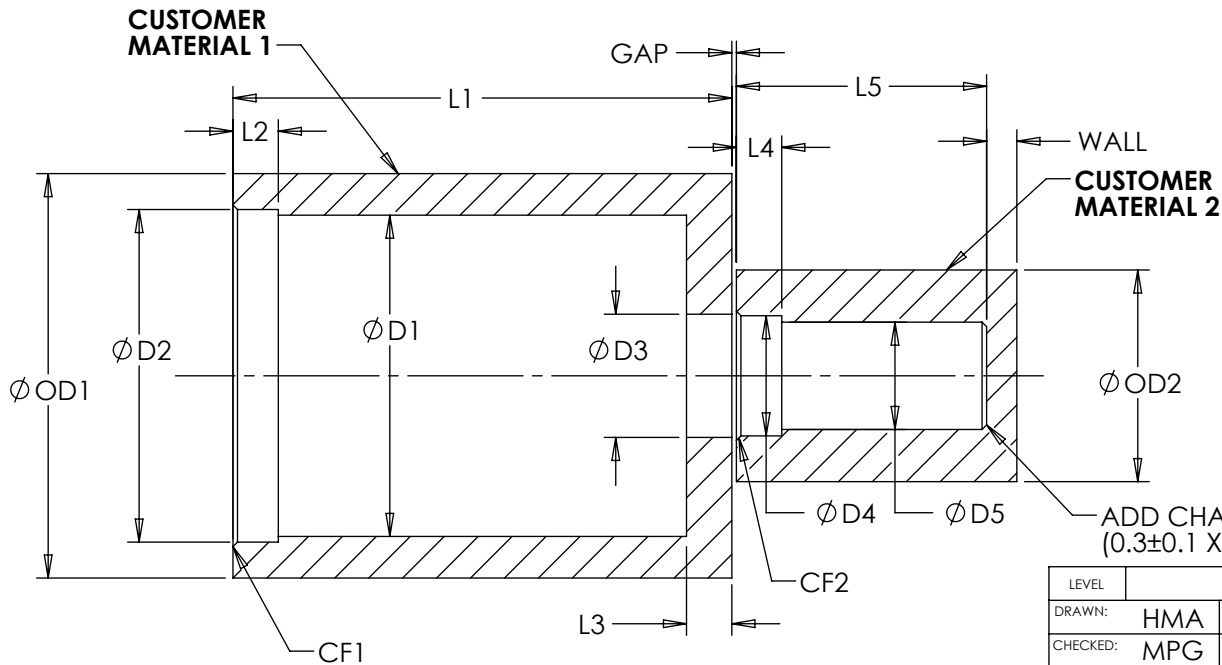
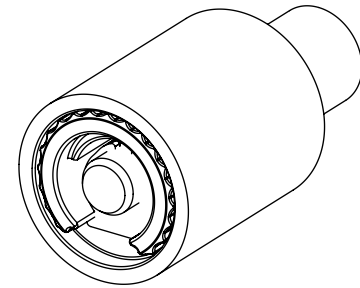
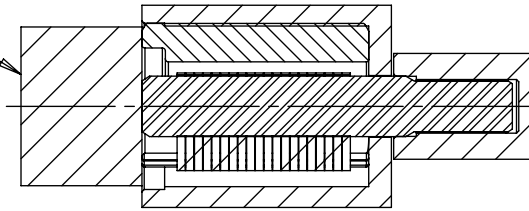

CUSTOMER MATERIAL 1 AND CUSTOMER MATERIAL 2 ALIGNMENT TO BE WITHIN 0.15mm IN ANY DIRECTION.

ADD CHAMFER ONLY IF NEEDED (0.3±0.1 X 45°±5°)

SCALE 2:1

SPECIFICATION SUBJECT TO CHANGE

LEVEL	DESCRIPTION	DRAWN	DATE	APPROVED
DRAWN:	HMA	DATE:	16APR12	REFERENCE:
CHECKED:	MPG	DATE:	26APR17	
APPROVED:	MPG	DATE:	26APR17	TITLE:
REVISED:	23JUN20	DIMS:	mm	SALES DRAWING
		PART NO:	TI-360	REV:
<small>REELL PRECISION MANUFACTURING 1259 WILLOW LAKE BOULEVARD SAINT PAUL, MINNESOTA 55110-5103, USA</small>		SCALE: 1:1	DO NOT SCALE DRAWING	C
			SHEET 5 OF 10	

INTERPRET PRINT PER ASME Y14.5M-1994
 THIS PRINT IS THE CONFIDENTIAL PROPERTY OF REELL PRECISION MFG.
 THIRD ANGLE PROJECTION

TI-360-X.XX-02 CUSTOMER INSTALLATION GEOMETRY

MATERIAL	D1	D2	D3	D4	R1	L1	L2	L3	L4	L5	L6	CF1	CF2	OD1	OD2	GAP	WALL
DELTRIN	21.3±0.05	22±0.03	21±0.03	18.5±0.03	3 MAX	32 MIN	2.5±0.1	4.5±0.1	21 MIN	8.5±0.1	(12)	0.3±0.1 X 45°±5°	0.3±0.1 X 45°±5°	30 MIN	25 MIN	(0.3)	2 MIN

- * DELTRIN DIMENSIONS SPECIFIED. OTHER PLASTICS MAY REQUIRE DIFFERENT MOUNTING OPTIONS.
- * D-PROFILE IN CUSTOMER MATERIAL 1 IS RECOMMENDED FOR PROPER ALIGNMENT IN PLASTIC MATERIALS.
- * CUSTOMER MATERIAL 1 AND CUSTOMER MATERIAL 2 ALIGNMENT TO BE WITHIN 0.15mm IN ANY DIRECTION.
- * SEE NEXT PAGE FOR INSTALLATION RECOMMENDATIONS.

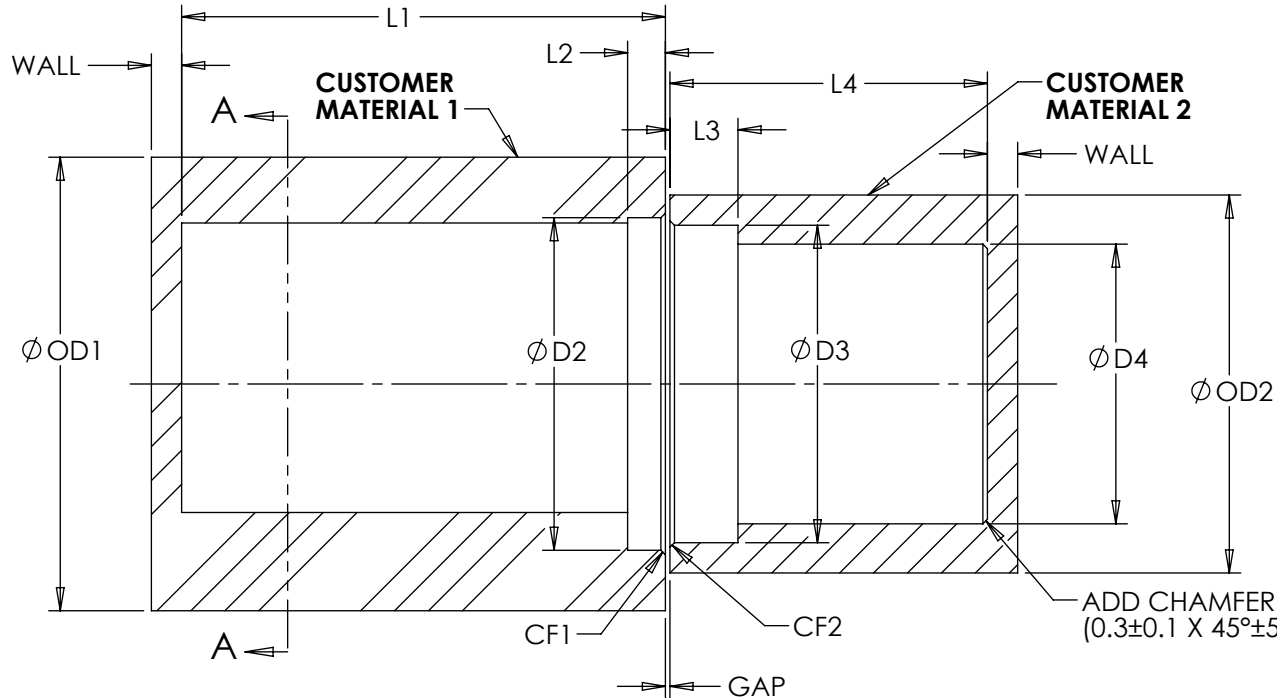

SCALE 2:1

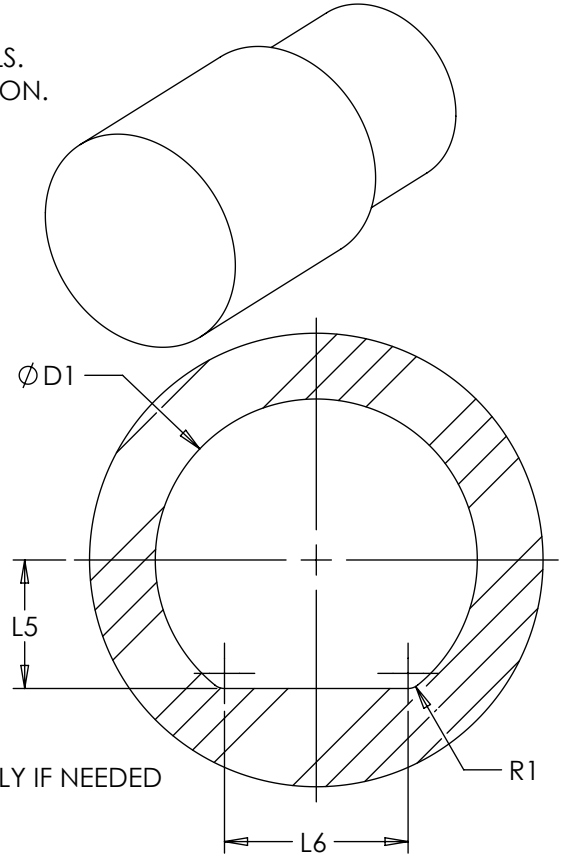

SECTION A-A SCALE 2:1
CUSTOMER MATERIAL 1



TDS Precision Products GmbH
Industriestrasse 1a
CH-8157 Dielsdorf

T + 41 44 885 30 80
info@tds-pp.com
www.tds-pp.com

INTERPRET PRINT PER
ASME Y14.5M-1994
THIS PRINT IS THE
CONFIDENTIAL PROPERTY
OF REELL PRECISION MFG.

THIRD ANGLE PROJECTION

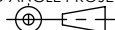

LEVEL	DESCRIPTION		DRAWN	DATE	APPROVED
DRAWN:	HMA	DATE: 16APR12	REFERENCE:		
CHECKED:	MPG	DATE: 26APR17	TITLE:		
APPROVED:	MPG	DATE: 26APR17	SALES DRAWING		
REVISED:	23JUN20	DIMS: mm			
			PART NO:		REV:
			TI-360		C
REELL PRECISION MANUFACTURING 1259 WILLOW LAKE BOULEVARD SAINT PAUL, MINNESOTA 55110-5103, USA		SCALE: 1:1	DO NOT SCALE DRAWING	SHEET 6 OF 10	

SPECIFICATION SUBJECT TO CHANGE

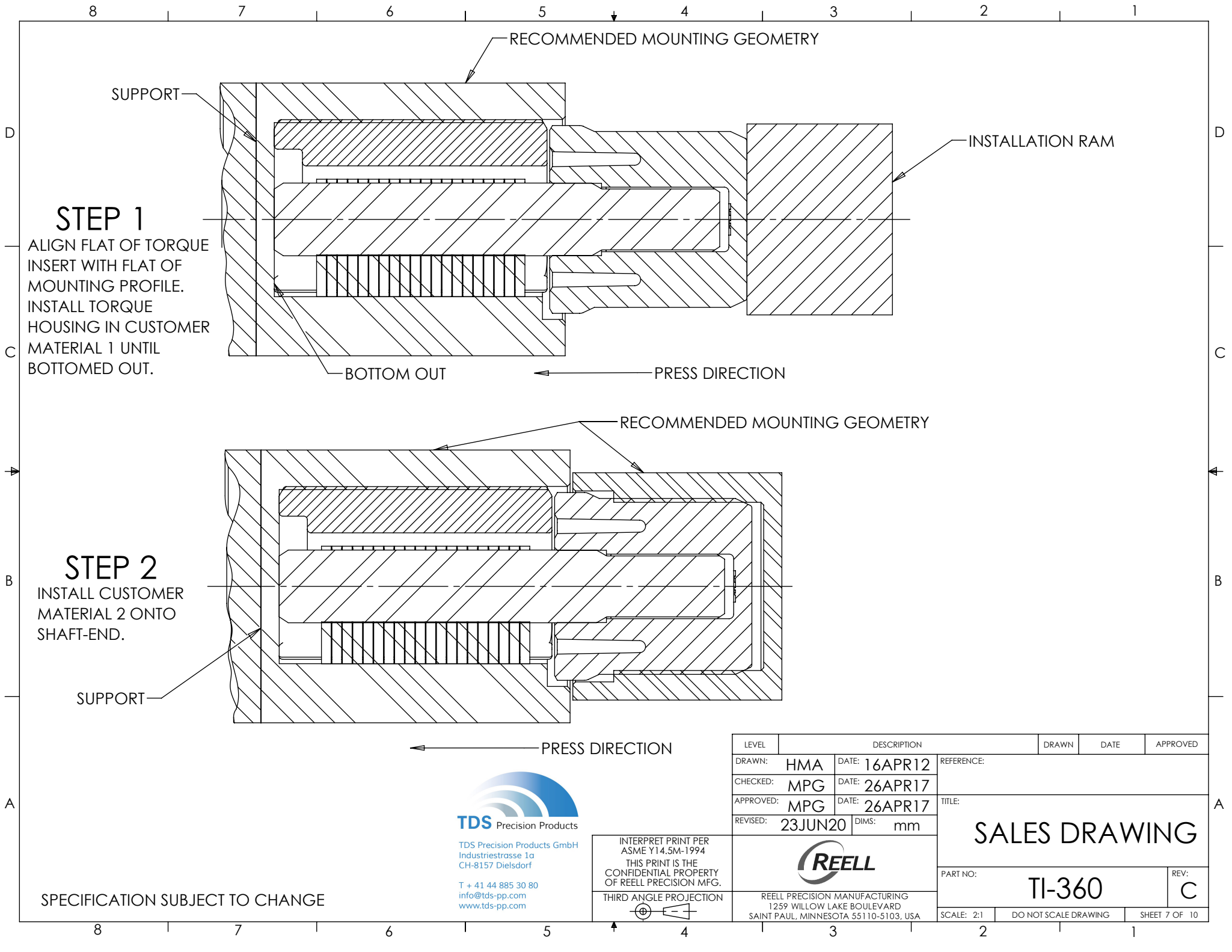

SPECIFICATION SUBJECT TO CHANGE

TDS Precision Products
 TDS Precision Products GmbH
 Industriestrasse 1a
 CH-8157 Dielsdorf
 T + 41 44 885 30 80
 info@tds-pp.com
 www.tds-pp.com

INTERPRET PRINT PER ASME Y14.5M-1994
 THIS PRINT IS THE CONFIDENTIAL PROPERTY OF REELL PRECISION MFG.
 THIRD ANGLE PROJECTION

LEVEL	DESCRIPTION	DRAWN	DATE	APPROVED
DRAWN:	HMA	DATE:	16APR12	REFERENCE:
CHECKED:	MPG	DATE:	26APR17	TITLE: SALES DRAWING
APPROVED:	MPG	DATE:	26APR17	
REVISED:	23JUN20	DIMS:	mm	
 REELL PRECISION MANUFACTURING 1259 WILLOW LAKE BOULEVARD SAINT PAUL, MINNESOTA 55110-5103, USA		PART NO:		REV:
		TI-360		C
SCALE: 2:1		DO NOT SCALE DRAWING		SHEET 7 OF 10

TI-360-X.XX-03 AND TI-360-X.XX-04 CUSTOMER INSTALLATION GEOMETRY

MATERIAL	D1	D2	D3	D4	L1	L2	L3	L4	CF1	CF2	OD1	OD2	WALL	GAP
DIE CAST ZINC	21.5±0.05	22±0.03	21.25±0.03	15.53±0.03	32.4 MIN	3±0.1	2.5±0.1	24.5 MIN	0.3±0.1 X 45°±5°	0.3±0.1 X 45°±5°	26.75 MIN	25 MIN	2 MIN	(0.3)
DIE CAST ALUMINUM														
MILD STEEL	21.63±0.025			15.57±0.015										
WROUGHT ALUMINUM														

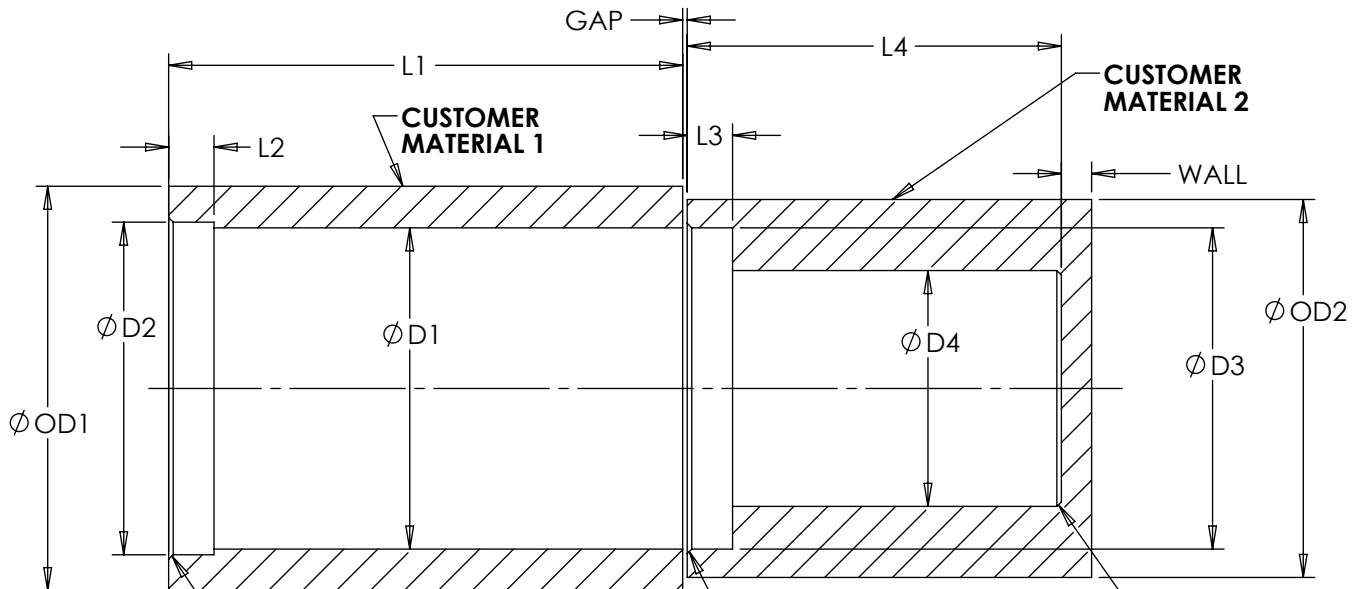
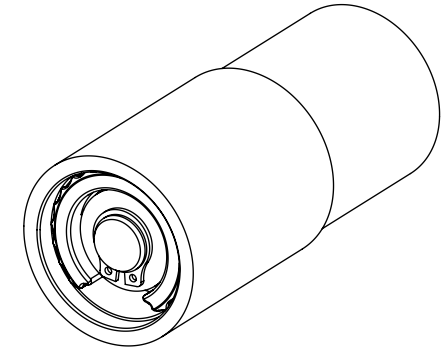
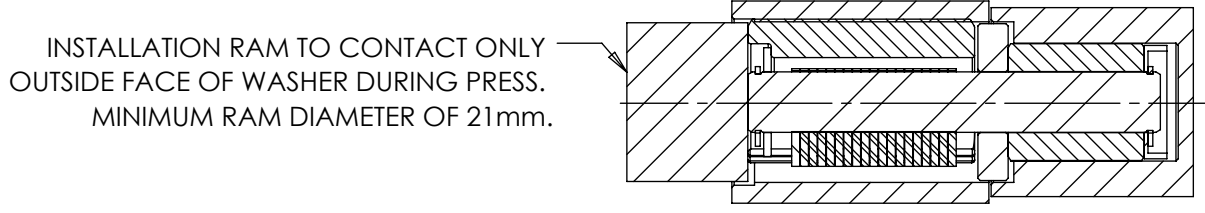

CUSTOMER MATERIAL 1 AND CUSTOMER MATERIAL 2 ALIGNMENT TO BE WITHIN 0.15mm IN ANY DIRECTION.

SPECIFICATION SUBJECT TO CHANGE

LEVEL	DESCRIPTION		DRAWN	DATE	APPROVED
DRAWN:	HMA	DATE: 16APR12	REFERENCE:		
CHECKED:	MPG	DATE: 26APR17	TITLE:		
APPROVED:	MPG	DATE: 26APR17	SALES DRAWING		
REVISED:	23JUN20	DIMS: mm			
			PART NO: TI-360		REV: C
<small>REELL PRECISION MANUFACTURING 1259 WILLOW LAKE BOULEVARD SAINT PAUL, MINNESOTA 55110-5103, USA</small>			SCALE: 1:1	DO NOT SCALE DRAWING	SHEET 8 OF 10

INTERPRET PRINT PER ASME Y14.5M-1994
THIS PRINT IS THE CONFIDENTIAL PROPERTY OF REELL PRECISION MFG.
THIRD ANGLE PROJECTION

TI-360-X.XX-05 CUSTOMER INSTALLATION GEOMETRY

MATERIAL	D1	D2	D3	D4	D5	L1	L2	L3	L4	L5	L6	L7	CF1	CF2	OD1	OD2	WALL	GAP
DIE CAST ZINC	21.5±0.05	22±0.03	8.15±0.03	7.95±0.03	7.15±0.03	33±0.1	3±0.1	3±0.1	3±0.1	15.7±0.1	6.5±0.1	20.5 MIN	0.3±0.1 X 45°±5°	0.3±0.1 X 45°±5°	26.75 MIN	14 MIN	2 MIN	(0.3)
DIE CAST ALUMINUM																		
MILD STEEL	21.63 ±0.025	22±0.03	8.15±0.03	8.05±0.03	7.2±0.03	33±0.1	3±0.1	3±0.1	3±0.1	15.7±0.1	6.5±0.1	20.5 MIN	0.3±0.1 X 45°±5°	0.3±0.1 X 45°±5°	26.75 MIN	14 MIN	2 MIN	(0.3)
WROUGHT ALUMINUM																		

SEE NEXT PAGE FOR
INSTALLATION SUGGESTIONS

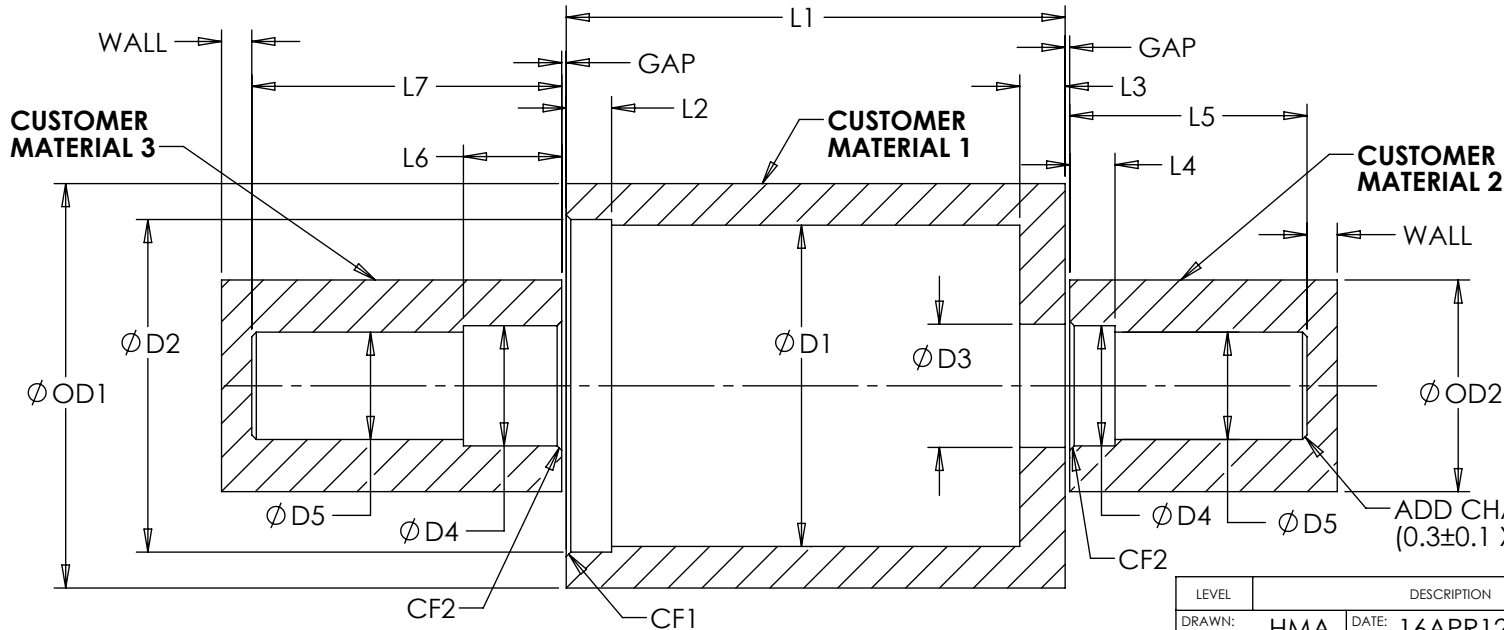
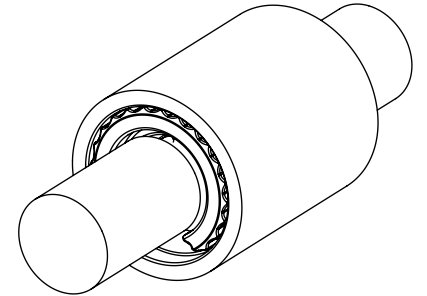
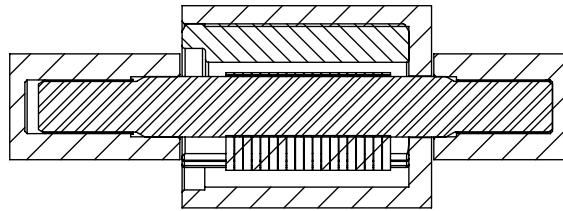

CUSTOMER MATERIAL 2
AND CUSTOMER MATERIAL 3
ALIGNMENT TO BE WITHIN
0.15mm IN ANY DIRECTION
OF CUSTOMER MATERIAL 1.

SCALE 2:1

LEVEL	DESCRIPTION	DRAWN	DATE	APPROVED
DRAWN:	HMA	DATE:	16APR12	REFERENCE:
CHECKED:	MPG	DATE:	26APR17	TITLE:
APPROVED:	MPG	DATE:	26APR17	
REVISED:	23JUN20	DIMS:	mm	<h2 style="margin: 0;">SALES DRAWING</h2>
REELL PRECISION MANUFACTURING 1259 WILLOW LAKE BOULEVARD SAINT PAUL, MINNESOTA 55110-5103, USA				PART NO:
				TI-360
				REV: C
SCALE: 1:1		DO NOT SCALE DRAWING		SHEET 9 OF 10

INTERPRET PRINT PER
ASME Y14.5M-1994
THIS PRINT IS THE
CONFIDENTIAL PROPERTY
OF REELL PRECISION MFG.
THIRD ANGLE PROJECTION

SPECIFICATION SUBJECT TO CHANGE

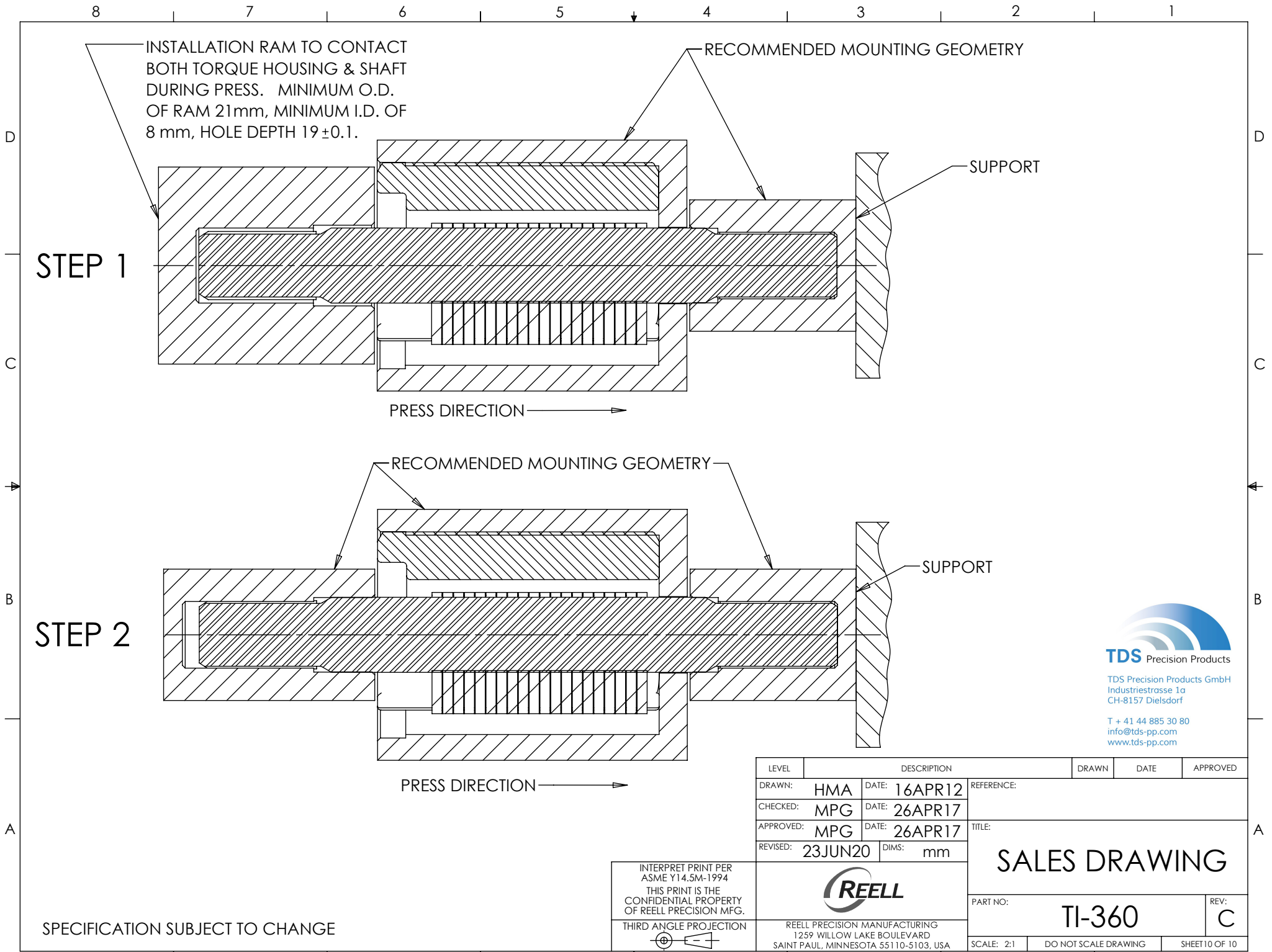

STEP 1

STEP 2

INSTALLATION RAM TO CONTACT BOTH TORQUE HOUSING & SHAFT DURING PRESS. MINIMUM O.D. OF RAM 21mm, MINIMUM I.D. OF 8 mm, HOLE DEPTH 19±0.1.

RECOMMENDED MOUNTING GEOMETRY

SUPPORT

PRESS DIRECTION →

RECOMMENDED MOUNTING GEOMETRY

SUPPORT

PRESS DIRECTION →

TDS Precision Products
 TDS Precision Products GmbH
 Industriestrasse 1a
 CH-8157 Dielsdorf
 T + 41 44 885 30 80
 info@tds-pp.com
 www.tds-pp.com

LEVEL	DESCRIPTION	DRAWN	DATE	APPROVED
DRAWN:	HMA	DATE:	16APR12	REFERENCE:
CHECKED:	MPG	DATE:	26APR17	TITLE:
APPROVED:	MPG	DATE:	26APR17	
REVISED:	23JUN20	DIMS:	mm	
 REELL PRECISION MANUFACTURING 1259 WILLOW LAKE BOULEVARD SAINT PAUL, MINNESOTA 55110-5103, USA		PART NO:		REV:
		TI-360		C
SCALE: 2:1		DO NOT SCALE DRAWING		SHEET 10 OF 10

INTERPRET PRINT PER ASME Y14.5M-1994
 THIS PRINT IS THE CONFIDENTIAL PROPERTY OF REELL PRECISION MFG.
 THIRD ANGLE PROJECTION

SPECIFICATION SUBJECT TO CHANGE