

TI - XXX - X.X

TYPE
- 220
- 240

TORQUE N-m

- 220
- 1.5
- 2.0
- 2.5
- 3.0
- 3.5

- 240
- 2.0
- 3.0
- 4.0
- 5.0
- 6.0
- 7.0
- 8.0

CATALOG NUMBER	CCW HIGH DYNAMIC TORQUE			CW LOW DYNAMIC TORQUE		
	NOMINAL	LB-IN	INITIAL TOLERANCE	NOMINAL	INITIAL TOLERANCE	
	Nm	LB-IN	+/- %	Nm	LB-IN	+/- %
TI-220-1.5	1.5	13.3	18	0.94	8.3	26
TI-220-2.0	2.0	17.7	15	1.25	11.1	23
TI-220-2.5	2.5	22.1	12	1.56	13.8	20
TI-220-3.0	3.0	26.6	12	1.88	16.6	20
TI-220-3.5	3.5	31.0	12	2.19	19.4	20
TI-240-2.0	2.0	17.7	22	1.25	11.1	32
TI-240-3.0	3.0	26.6	17	1.88	16.6	27
TI-240-4.0	4.0	35.4	12	2.50	22.1	20
TI-240-5.0	5.0	44.3	12	3.13	27.7	20
TI-240-6.0	6.0	53.1	12	3.75	33.2	20
TI-240-7.0	7.0	62.0	12	4.38	38.7	20
TI-240-8.0	8.0	70.8	12	5.00	44.3	20

NOTES:

- DESIGNED TO BE INSERT MOLDED INTO GLASS FILLED NYLON WITH 16 TO 17mm OD. DO NOT PREHEAT INSERT. DO NOT CYCLE MOLDED HINGE LEAVES UNTIL PLASTIC IS FULLY CURED - 16 HOURS MIN.
- LIFE: (ONE CYCLE CONSISTS OF 180° OPEN AND 180° CLOSED)
TI-220 = 10,000 CYCLES MIN.
TI-240 = 20,000 CYCLES MIN.
- AVAILABLE TORQUE: SEE TABULATION
- APPLICATION CONDITIONS REFERENCE. USER MUST DETERMINE FITNESS FOR USE IN APPLICATION. APPLICATIONS NORMALLY EXPERIENCE AN ADDITIONAL 10% VARIATION IN TORQUE AFTER MOLDING AND OVER LIFE. STATIC TORQUE IS NORMALLY WITHIN 10% OF DYNAMIC TORQUE.



TDS Precision Products GmbH
Industriestrasse 1a
CH-8157 Dielsdorf

T + 41 44 885 30 80
info@tds-pp.com
www.tds-pp.com

INTERPRET PRINT PER ASME Y14.5M-1994
THIS PRINT IS THE CONFIDENTIAL PROPERTY OF REELL PRECISION MFG.

THIRD ANGLE PROJECTION

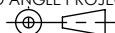

LEVEL	DESCRIPTION		DRAWN	DATE	APPROVED
DRAWN:	HMA	DATE: 17JAN13	PART NO.: 7-XXX & 83111-XXX		
CHECKED:	STK	DATE: 04MAR13	TITLE: ReellTorq INSERT		
APPROVED:	STK	DATE: 04MAR13	DESCRIPTION: TI 2XX		
REVISED:	24SEP19	DIMS: mm[IN]	REV: F		
REELL PRECISION MANUFACTURING 1259 WILLOW LAKE BOULEVARD SAINT PAUL, MINNESOTA 55110-5103, USA		SCALE: 1:1		DO NOT SCALE DRAWING	SHEET 1 OF 3

SPECIFICATIONS SUBJECT TO CHANGE

TI - 220 - X.X

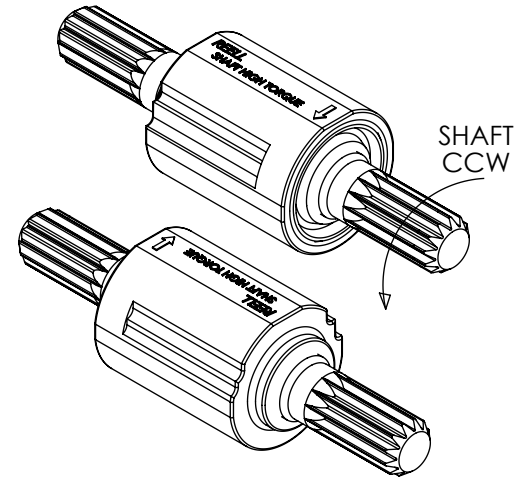
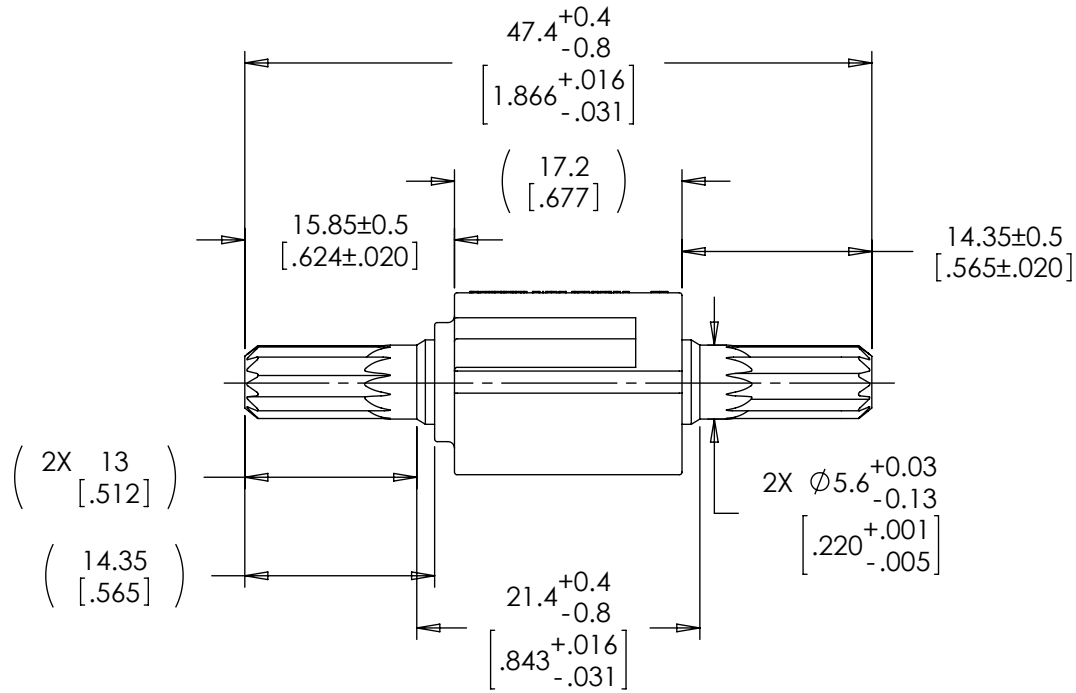
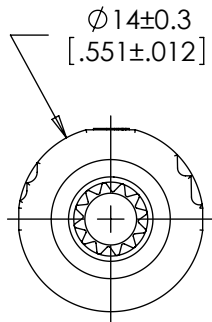

TDS Precision Products
 TDS Precision Products GmbH
 Industriestrasse 1a
 CH-8157 Dielsdorf
 T + 41 44 885 30 80
 info@tds-pp.com
 www.tds-pp.com

INTERPRET PRINT PER
 ASME Y14.5M-1994
 THIS PRINT IS THE
 CONFIDENTIAL PROPERTY
 OF REELL PRECISION MFG.
 THIRD ANGLE PROJECTION

LEVEL	DESCRIPTION	DRAWN	DATE	APPROVED
DRAWN: HMA	DATE: 17JAN13	PART NO.: 7-XXX		
CHECKED: STK	DATE: 04MAR13	TITLE: ReellTorq INSERT		
APPROVED: STK	DATE: 04MAR13	DESCRIPTION: TI 2XX		
REVISED: 24SEP19	DIMS: mm[IN]	REV: F		
REELL PRECISION MANUFACTURING 1259 WILLOW LAKE BOULEVARD SAINT PAUL, MINNESOTA 55110-5103, USA		SCALE: 1:1	DO NOT SCALE DRAWING	SHEET 2 OF 3

SPECIFICATIONS SUBJECT TO CHANGE

TI - 240 - X.X

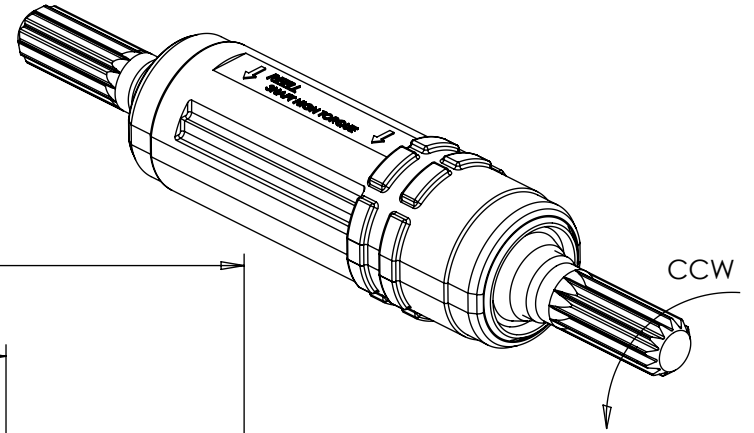
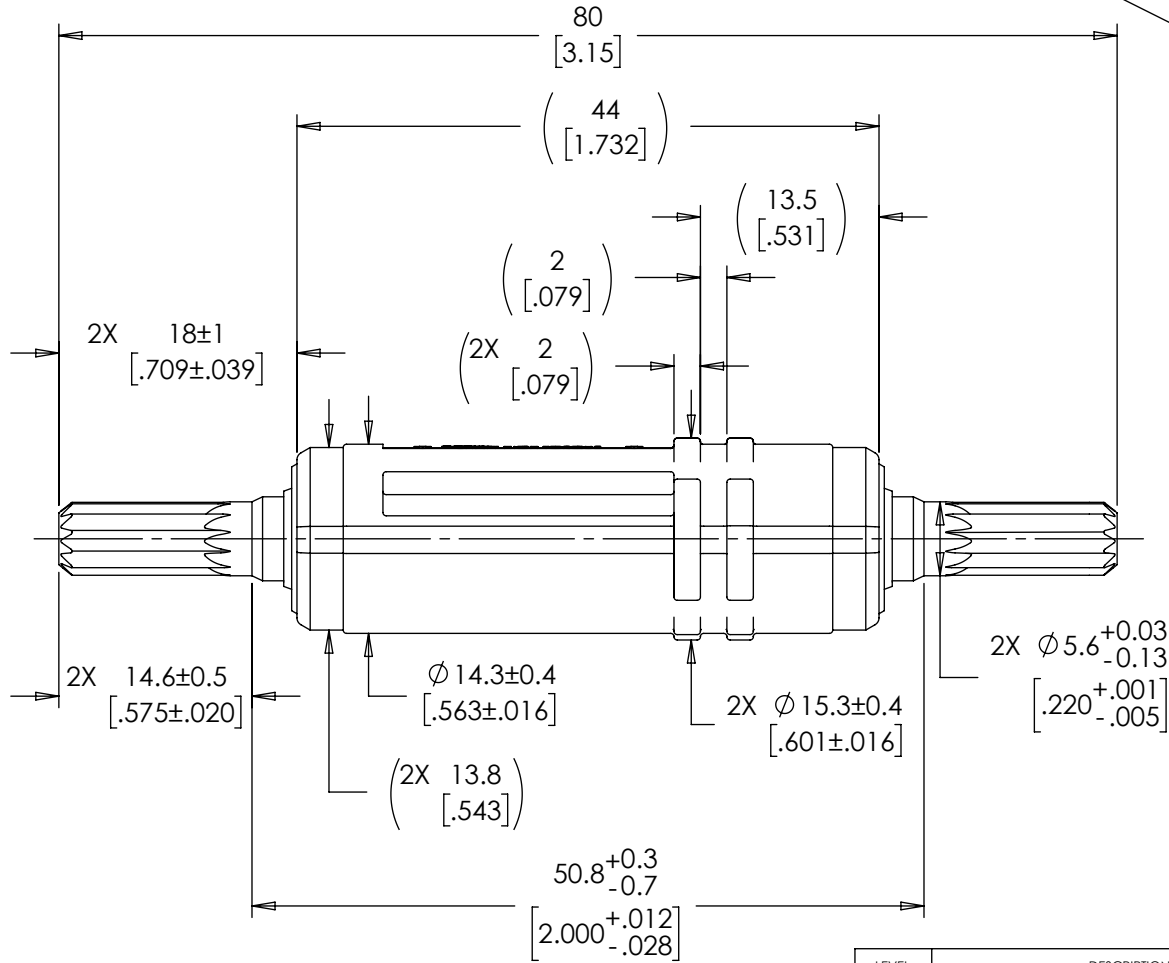
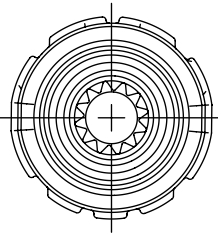

SPECIFICATIONS SUBJECT TO CHANGE



TDS Precision Products GmbH
 Industriestrasse 1a
 CH-8157 Dielsdorf
 T + 41 44 885 30 80
 info@tds-pp.com
 www.tds-pp.com

INTERPRET PRINT PER
 ASME Y14.5M-1994
 THIS PRINT IS THE
 CONFIDENTIAL PROPERTY
 OF REELL PRECISION MFG.

THIRD ANGLE PROJECTION

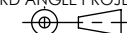

LEVEL	DESCRIPTION	DRAWN	DATE	APPROVED
DRAWN: HMA	DATE: 17JAN13	PART NO.: 83111-XXX		
CHECKED: STK	DATE: 04MAR13			
APPROVED: STK	DATE: 04MAR13	TITLE: ReellTorq INSERT		
REVISED: 24SEP19	DIMS: mm[IN]	DESCRIPTION: TI 2XX		REV: F
REELL PRECISION MANUFACTURING 1259 WILLOW LAKE BOULEVARD SAINT PAUL, MINNESOTA 55110-5103, USA		SCALE: 1:1	DO NOT SCALE DRAWING	SHEET 3 OF 3