

CATALOG CODE

SJ - 200 - X.XXX - XX - XX

TORQUE Nm
0.20S - SYMMETRIC
0.40S - SYMMETRIC

SHAFT END
01 - EXTERNAL M4

MOUNTING TYPE
01 - COUNTERBORE

NOTES:

1. USER MUST DETERMINE FITNESS FOR USE IN APPLICATION.
2. DYNAMIC TORQUE AND PART NUMBERS SEE PAGE 2.
3. ENVIRONMENTAL CONDITIONS: -20° TO +80°C. UP TO 10% OF LIFE CYCLES AT HOT AND COLD CONDITIONS.
4. LIFE CYCLE: 50,000 TOTAL ADJUSTMENTS. ONE ADJUSTMENT EQUALS MOVEMENT IN ANY DIRECTION UP TO FULL TRAVEL, OR 90° MAX WHEN DUTY CYCLE IS LESS THAN 10% AND SPEED IS LESS THAN 60 RPM.
5. PART MARKED WITH DATE (MOYR) AND TORQUE ORDER NUMBER.
EXAMPLE: 0418
0.20S
6. MATERIAL:
COVER AND BASE: ENGINEERED PLASTIC
SHAFT: NITRIDED STEEL
BALL AND TORQUE ELEMENT: HARDENED STEEL
LUBRICANT: MINERAL OIL BASED
7. SHAFT TO COVER ANGLE NOT CONTROLLED.
8. MAX BENDING MOMENT ON SHAFT = 2.8 Nm [25 LB-IN].



TDS Precision Products GmbH
Industriestrasse 1a
CH-8157 Dielsdorf

T + 41 44 885 30 80
info@tds-pp.com
www.tds-pp.com

INTERPRET PRINT PER ASME Y14.5M-1994
THIS PRINT IS THE CONFIDENTIAL PROPERTY OF REELL PRECISION MFG.

THIRD ANGLE PROJECTION

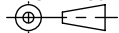

LEVEL	DESCRIPTION		DRAWN	DATE	APPROVED
DRAWN:	TDJ	DATE: 11MAY17	PART NO:		
CHECKED:	TDJ	DATE: 22MAY18	TITLE:		
APPROVED:	TDJ	DATE: 22MAY18	SALES DRAWING		
REVISED:	19OCT20	DIMS: mm			
REELL PRECISION MANUFACTURING 1259 WILLOW LAKE BOULEVARD SAINT PAUL, MINNESOTA 55110-5103, USA			REFERENCE:	SJ-200	REV: B
SCALE: 1:1			DO NOT SCALE DRAWING		SHEET 1 OF 2

SPECIFICATION SUBJECT TO CHANGE

CATALOG CODE	DYNAMIC TORQUE								
	PRIMARY TORQUE		PRIMARY TORQUE TOLERANCE	SECONDARY TORQUE		SECONDARY TORQUE TOLERANCE	ROTATIONAL TORQUE		ROTATIONAL TORQUE TOLERANCE
	Nm	[LB-IN]		Nm	[LB-IN]		Nm	[LB-IN]	
SJ-200-0.20S-01-01	0.2	1.77	±30%	0.2	1.77	±30%	0.3	2.66	±30%
SJ-200-0.40S-01-01	0.4	3.54	±30%	0.4	3.54	±30%	0.6	5.32	±30%

PRODUCT TORQUE SPECIFICATION AT +20°C.

SJ - 200 - X.XXS -01 -01

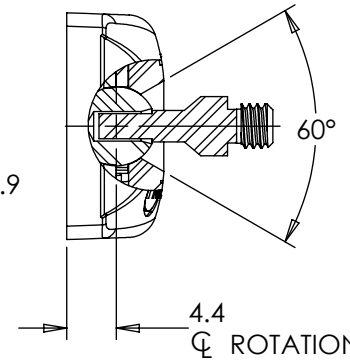
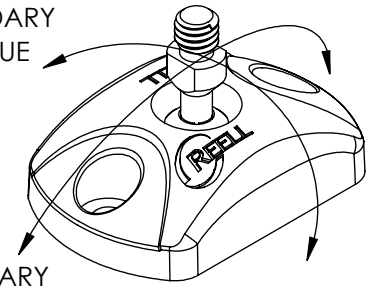
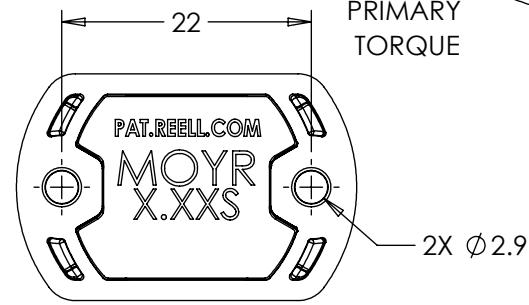
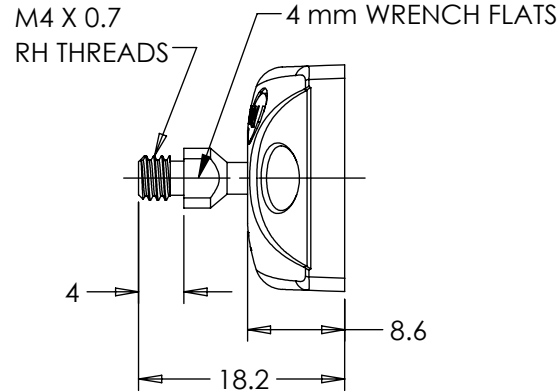
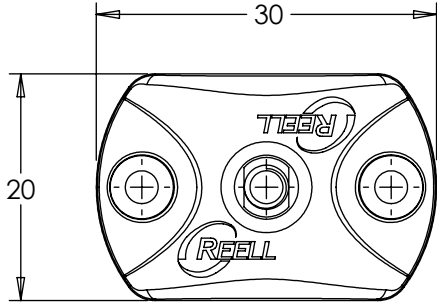

CUSTOMER MOUNTING CONFIGURATION

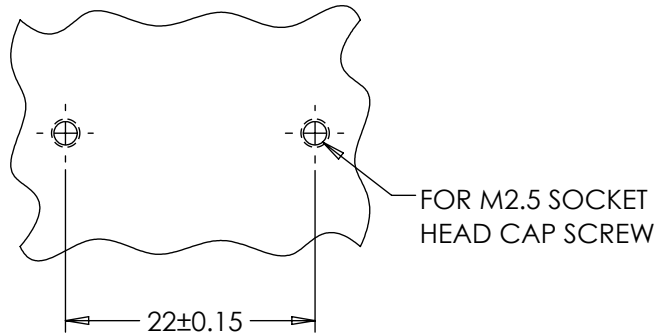

SPECIFICATION SUBJECT TO CHANGE

ALL DIMENSIONS REFERENCE
SEE CAD MODEL FOR UNSPECIFIED FEATURES

TDS Precision Products
 TDS Precision Products GmbH
 Industriestrasse 1a
 CH-8157 Dielsdorf
 T + 41 44 885 30 80
 info@tds-pp.com
 www.tds-pp.com

INTERPRET PRINT PER
 ASME Y14.5M-1994
 THIS PRINT IS THE
 CONFIDENTIAL PROPERTY
 OF REELL PRECISION MFG.
 THIRD ANGLE PROJECTION

LEVEL	DESCRIPTION	DRAWN	DATE	APPROVED
DRAWN:	TDJ	DATE:	11MAY17	PART NO:
CHECKED:	TDJ	DATE:	22MAY18	
APPROVED:	TDJ	DATE:	22MAY18	
REVISED:	19OCT20	DIMS:	mm	TITLE:
				SALES DRAWING
				REFERENCE: SJ-200
SCALE: 1.5:1		DO NOT SCALE DRAWING		SHEET 2 OF 2

REELL PRECISION MANUFACTURING
 1259 WILLOW LAKE BOULEVARD
 SAINT PAUL, MINNESOTA 55110-5103, USA