

DIRECTION OF HIGH TORQUE

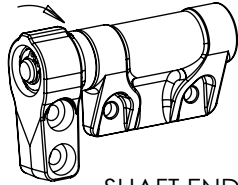

SHAFT END RIGHT

DIRECTION OF HIGH TORQUE

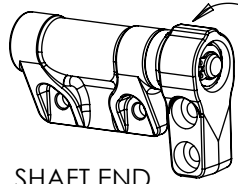

SHAFT END RIGHT

NOTES:

1. USER MUST DETERMINE FITNESS FOR USE IN APPLICATION.
2. LIFE: 20,000 CYCLES WHEN DUTY CYCLE IS LESS THAN 10% AND ROTATIONAL SPEED IS LESS THAN 100 RPM. 10 SECONDS MAXIMUM CONTINUOUS ACTUATION.
3. DESIGNED TO ACCEPT M4 OR #8 SCREW OR EQUIVALENT.
4. SHAFT END MAY ROTATE IN BULK SHIPPING.
5. MATERIAL:
 ZINC BRACKET
 ZINC SHAFT END
 HARDENED STEEL SHAFT
 HARDENED STEEL TORQUE ELEMENT
 POWDERED METAL BEARINGS

CATALOG CODE PHT-X.X-XX

TORQUE Nm
2.0
4.0
6.0

HINGE TYPE
01 - LEFT
02 - RIGHT

TDS Precision Products
 TDS Precision Products GmbH
 Industriestrasse 1a
 CH-8157 Dielsdorf
 T + 41 44 885 30 80
 info@tds-pp.com
 www.tds-pp.com

INTERPRET PRINT PER
 ASME Y14.5M-1994
 THIS PRINT IS THE
 CONFIDENTIAL PROPERTY
 OF REELL PRECISION MFG.

THIRD ANGLE PROJECTION

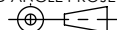

LEVEL	DESCRIPTION	DRAWN	DATE	APPROVED
DRAWN: HMA	DATE: 17SEP14	PART NO:		
CHECKED: ESA	DATE: 22SEP14	TITLE:		
APPROVED: ESA	DATE: 22SEP14	SALES DRAWING		
REVISED: 02JUN20	DIMS: mm			
 REELL PRECISION MANUFACTURING 1259 WILLOW LAKE BOULEVARD SAINT PAUL, MINNESOTA 55110-5103, USA		DESCRIPTION: PHT		REV: M
		SCALE: 1:1	DO NOT SCALE DRAWING	SHEET 1 OF 2

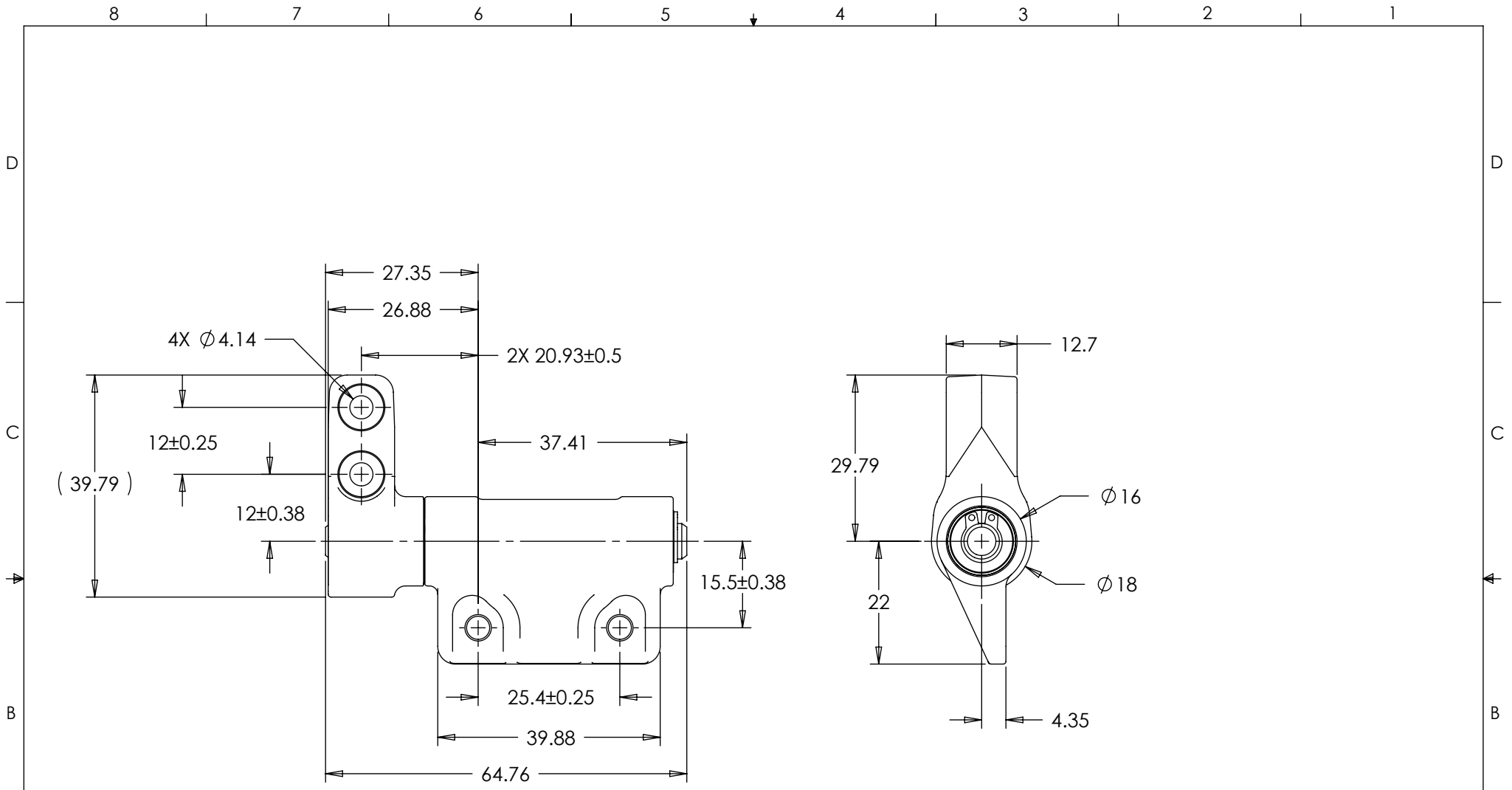

LEFT SHOWN, BUT DIMENSIONS APPLY TO BOTH LEFT AND RIGHT

ALL DIMENSIONS REFERENCE SEE CAD MODEL FOR UNSPECIFIED FEATURES.



TDS Precision Products
 TDS Precision Products GmbH
 Industriestrasse 1a
 CH-8157 Dielsdorf
 T + 41 44 885 30 80
 info@tds-pp.com
 www.tds-pp.com

LEVEL	DESCRIPTION		DRAWN	DATE	APPROVED
DRAWN:	HMA	DATE: 17SEP14	PART NO:		
CHECKED:	ESA	DATE: 22SEP14	TITLE:		
APPROVED:	ESA	DATE: 22SEP14	SALES DRAWING		
REVISED:	02JUN20	DIMS: mm			
 REELL PRECISION MANUFACTURING 1259 WILLOW LAKE BOULEVARD SAINT PAUL, MINNESOTA 55110-5103, USA			DESCRIPTION: PHT		REV: M
			SCALE: 1:1	DO NOT SCALE DRAWING	SHEET 2 OF 2

INTERPRET PRINT PER ASME Y14.5M-1994
 THIS PRINT IS THE CONFIDENTIAL PROPERTY OF REELL PRECISION MFG.
 THIRD ANGLE PROJECTION

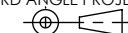

SPECIFICATIONS SUBJECT TO CHANGE