

# Data Sheet for Angle Sensors

## Hall-Effect Single-Turn Rotary Encoder

T + 41 44 885 30 80  
info@tds-pp.com  
www.tds-pp.com

## Series MIB28



- Up to 1024 pulses per revolution (4096 steps)
- Supply voltage 5 V, 24 V
- Electrical Interfaces: Open Collector, NPN, Push-Pull
- High operational shaft speeds thanks to ball bearings
- Robust metal housing
- IP65

The MIB28 is a magnetic incremental encoder. With classical optical incremental encoders, environmental influences can affect the optical system also light emitting components aging by its operational life. Both influences could have impact to the reliability. The MIB28 is free from these technology-related restrictions of classic optic incremental encoders and then the first choice, if incremental encoders with requirements to a very long service life are required.

### Electrical Data

Output Signal	TTL	Push-Pull	Open Collector	
Number of pulses	1024, 512, 256, 1-128 Imp./Rev.			
Limit frequency	100 kHz			
Switch-on delay	20 ms			
Supply voltage	3.3 VDC ±10%	5 VDC ±10%	10...30 V	10...30 V
Power consumption (no load)	≤ 15 mA		≤ 50 mA	≤ 25 mA
Output load	≥ 5 kOhm			
Max. Pull-Up Voltage				30 VDC
Insulation voltage <sup>1.)</sup>	1000 VAC @ 50 Hz, 1 min			
Insulation resistance <sup>1.)</sup>	2 MOhm @ 500 VDC, 1 min			

### Mechanical and Environmental Data, Miscellaneous

Mechanical angle of rotation / stroke	360° without stop
Bearing	2 x ball bearing
Max. operational speed	6000 rpm
Operating temperature range	-40..+85 °C (fixed cable, extended temperature range on request)
Storage temperature range	-40..+105 °C
Protection grade (IEC 60529) standard	IP65
Housing diameter	28 mm
Housing depth	29,5 mm (axial cable), 37 mm (radial cable)
Shaft diameter	6 mm
Shaft type	Solid shaft
Connection type	Round cable AWG26 1 m
Connection position	Axial or radial
Sensor mounting	Threaded hole
Mass	app. 90 g
Fastening parts included in delivery	None
Material shaft	Stainless steel
Material housing	Aluminium

# Data Sheet for Angle Sensors

## Hall-Effect Single-Turn Rotary Encoder

Series MIB28

### Immunity

EN 61000-4-2 ESD	Class B
EN 61000-4-3 RF sine wave	Class A
EN 61000-4-6 Conducted sine wave	Class A
EN 61000-4-8 Power frequency magnetic fields	Class A

- 1.) According IEC 60393
- 2.) Determined by climatic conditions according to IEC 68-1, para. 5.3.1 without load collectives

### Option zero point alignment (N)

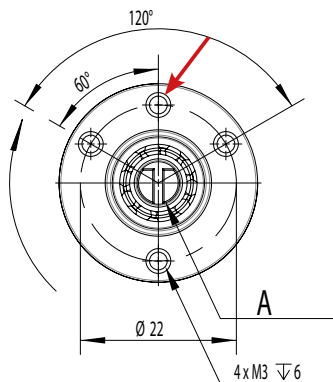

If option N is ordered, the index pulse (Z) is output when the shaft flattening faces the threaded hole, marked with the red arrow and the shaft slot is aligned with the center axis of the marked threaded hole (red arrow) - as shown in the drawing on the left side.

### Order Code

Description	Selection: Standard=black/bold, possible options=grey/cursive			
<b>Series</b>	<b>MIB28</b>			
<b>Number of pulses per revolution:</b> <b>1024</b> <i>Option: 512</i> <i>Option: 256</i> <i>Option: User defined number of pulses ≤ 128</i>		<b>1024</b> 512 256 XXX		
<b>Supply voltage / Output signal:</b> <b>VSUP=24 V (10...30 V) / OUT=A, B, Z, Push-Pull</b> <b>VSUP=24 V (10...30 V) / OUT=Open Collector</b> <b>VSUP=5 V ± 10% / OUT=A, B, Z, TTL</b>		<b>24BZPP</b> <b>24BZOC</b> <b>05BZTTL</b>		
<i>Zero point alignment</i>			N	
<b>Shaft diameter / shaft length:</b> <b>Standard Ø6 x 12 mm</b> <i>Option user defined shaft diameter, shaft length [mm] Ø≤6mm</i>			- XxXX	
<b>Electrical connection, signal cable output direction in dependency to the shaft:</b> <b>Round cable 1m, axial</b> <i>Option user defined round cable length [x,xx m], axial</i> <i>Option round cable 1 m, radial</i> <i>Option user defined radial round cable length [x,xx m], radial</i>				- CVx,xx CVR CVRx,xx

### Order examples MIB28:

#### Requirement:

Shaft Ø 6.00 mm, shaft length 12 mm, number of pulses 1024 ppr., VSUP=24 V, output signals A + B + index impulse (Z) + push pull electronics, no zero point alignment, signal cable output direction in dependency to the shaft - axial, cable length 1m

#### Example for order code:

MIB28 1024 24BZPP

# Data Sheet for Angle Sensors

Hall-Effect Single-Turn Rotary Encoder

Series MIB28

## Additional options

For higher quantities or on-going demand, additional options are available as described below on request

For example:

- Special shaft design
- Special cable assembly
- Output of absolute value by incrementing the signals after power on
- Alteration of the signal sequence and the index position

## Technical drawing

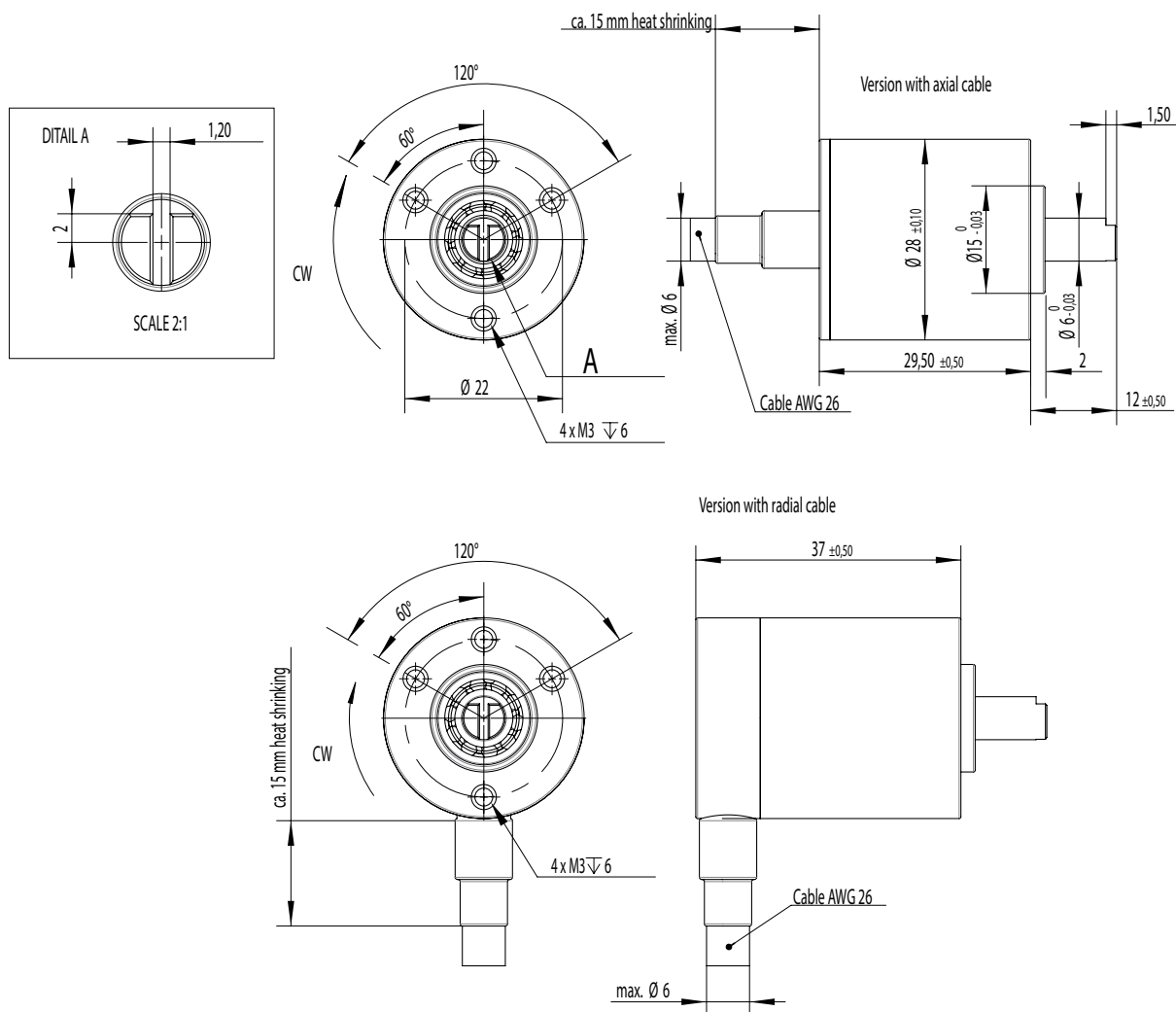

Option	Standard Cable Length L	Cable Cross Section	Allowed Tolerance
R	1000 mm	AWG26	-20 mm...+40 mm

# Data Sheet for Angle Sensors

## Hall-Effect Single-Turn Rotary Encoder

Series MIB28

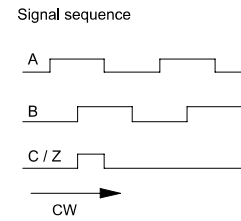
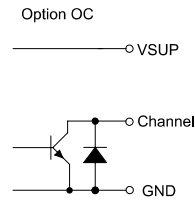
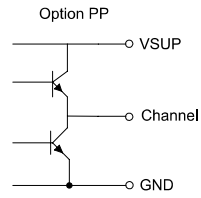
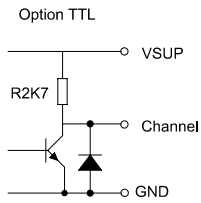

### Cable assignment for TTL, PP (push-pull) or OC (open collector) output

red	VSUP
black	GND
brown	A
orange	B
yellow	Z
green	NC