



- Ø25 mm aluminium metal housing
- Maximum life time expectation
- Magnetic, gradient-based signal evaluation
- Digital signal processing
- Protection IP68
- Operating temperature range -30..85°C
- Measurement range up to 360° singleturn, 72000° multiturn
- Programmable signal output function (factory or field-programmable/teach-in)
- Cable/connector outlet radial or axial
- Electrical connections M8 plug or round cable

HTx25K encoders – robust and versatile

The kit encoders of the HTx25K series are specially designed for applications in rough environments with limited space, where the rotation or angular position of externally mounted components are measured. The rugged contactless encoders in the Ø25 mm metal housing can be precisely matched to the respective area of application thanks to their numerous electronic and mechanical options. Whether as incremental or absolute value encoders, they cover a wide range of applications and, depending on the output electronics, are used in plant engineering, special machinery, and automated guided vehicles (AGVs), for example.

The HTx25K is the smallest metal-housed kit encoder in the MEGATRON product range. They feature a solid aluminium housing, a high IP protection and can be precisely aligned with the magnet in the application. The signal processing is digital and based on latest Hall sensor technology that ensure reliable magnetic recording of measured values. The gradient-based evaluation ensures high interference immunity, e. g. against temperature fluctuations and EMC influences.

In addition to many standard options, the modular system of the HTx25K encoders enables optimal adaptation to the respective requirements of the application. In addition, the concept also allows timely customer-specific adjustments (even in small series) based on a clearly structured price model. Typical modifications are, for example, customer-specific shaft geometries, custom signal output functions, special cable lengths or individually assembled electrical connection cables.

Output variants

<p>Singleturn absolute encoders</p>	<ul style="list-style-type: none"> ▪ Analogue voltage or current loop output (12 bit resolution) ▪ Analogue PWM output (12 bit resolution) ▪ Digital outputs SPI (also redundant), SER or SSI ▪ Absolute linearity up to 0.6%
<p>Programmable Multi- or singleturn absolute encoders</p>	<ul style="list-style-type: none"> ▪ Analogue voltage or current loop output (12 bit resolution) ▪ Not True-Power-On, max. 200 revolutions (72000°)
<p>Incremental encoders</p>	<ul style="list-style-type: none"> ▪ 1 to 1024 Impulses per revolution (ppr.) ▪ Outputs TTL, Push-Pull, Open Collector

Table of Contents

1. GENERAL INFORMATION AND INTRODUCTION	1
2. ELECTRONICS AND ORDER CODES	3
a. Absolute Single Turn Encoders	4
i. Analogue Current Loop or Voltage Output – HTA25K	4
ii. Redundant Analogue Voltage Output – HTA25KX	6
iii. Pulse Width Modulation (PWM) – HTP25K	8
iv. Serial output SPI, SPI or SSI – HTS25K	10
v. Redundant Serial Output SPI – HTS25KX	13
b. Incremental Encoders – HTI25K	15
c. Programmable Multi-/Singleturn Encoders with Analogue Output – HTA25KPM	18
3. TECHNICAL DRAWINGS	21
4. MECHANICAL DATA, COMPLIANCE AND ENVIRONMENTAL SPECIFICATIONS	24
5. ORDER CODES – FULL OVERVIEW	27
6. ACCESSORIES	28

General
Contents
Overview
Voltage/Current Redundant Analogue (HTA25K)
PWM (HTP25K)
SER/SPI/SSI Redundant Serial (HTS25K)
Incremental (HTI25K)
Multiturn HTA25KPM
Drawings
Technical Data
Accessories

Series overview

>>Please refer to the following sections for details

		Singleturn					Multiturn	
Series		HTI25K	HTS25K	HTS25KX	HTA25K	HTA25KX	HTP25K	HTA25KPM
Electronics redundant		NO	NO	YES	NO	YES	NO	NO
Output signal(s)		Incremental A, B, Z Optional: A, A/, B, B/, Z, Z/, UVW	Digital absolute SSI: 12 bit, UVW SPI: 14 bit SER: 12 bit	Digital absolute SPI: 14 bit	Analogue absolute 0 to 5 V 0 to 10 V 4 to 20 mA	Analogue absolute 0 to 5 V 0 to 10 V	PWM absolute 5 V / 244 Hz / PWM 10-90 %	Analogue absolute 0 to 5 V 0 to 10 V 4 to 20 mA
Effective electrical angle of rotation		360°			7° ≤ α ≤ 360° (programmable in factory)		7° ≤ α ≤ 360° (programmable in factory)	0-10° to 0-72000° (programmable by user) factory programming 0 to 3600°
Resolution		-	SSI: 12 bit SPI: 14 bit SER: 12 bit	SPI: 14 bit	12 bit			
Supply voltage(s)	Output type	Push-Pull, open collector	SPI, SER	SPI	Analogue 0 to 5 V	Analogue 0 to 5 V	PWM	Analogue 0 to 5 V
	Supply voltage	24 V (10 to 30 V)	5 V ± 10%	5 V ± 10%	5 V ± 10% (ratiometric) or 24 V (9 to 30 V)	5 V ± 10%	5 V ± 10%	24 V (9 to 30 V)
	Output type	TTL	SSI		Analogue 0 to 10 V	Analogue 0 to 10 V		Analogue 0 to 10 V
	Supply voltage	5 V ± 10%	24 V (10 to 30 V)		24 V (15 to 30 V)	24 V (15 to 30 V)		24 V (15 to 30 V)
	Output type				Current loop 4 to 20 mA			Current loop 4 to 20 mA
	Supply voltage				24 V (9 to 30 V)			24 V (11 to 30 V)
Programming options								
Programmable by customer		NO	NO	NO	NO	NO	NO	YES
Programmable ex works		YES	YES	YES	YES	YES	YES	YES

General
Contents
Overview
Voltage/Current
Redundant
Analogue (HTA25K)
PWM (HTP25K)
SER/SPI/SSI
Serial (HTS25K)
Redundant
Serial
Incremental (HTI25K)
Multiturn HTA25KPM
Drawings
Technical Data
Accessories

Series HTA25K

Key features HTA25K:

- Analogue outputs 0 to 5 V, 0 to 10 V, 4 to 20 mA
- Redundant versions available – see separate section
- Several factory programming possibilities
- Supply voltages: 5 VDC ±10%, 15 to 30 VDC, 9 to 30 VDC



Electrical data

Effective electrical angle of rotation 1.)	7° ≤ α ≤ 360° (programmable in factory), ±0.5°		
Independent linearity (best straight line) 1.)	±0.3% @ 360°		
Absolute Linearity 1.)	±0.6% @ 360°		
Output signal	0 to 5 V ratiometric	0 to 10 V	4 to 20 mA
Resolution	12 Bit		
Update rate	200 μs		
Supply voltage	5 V ±10%	15 to 30 V	9 to 30 V
Power consumption (no load)	≤ 18 mA		
Output load	≥ 5 kOhm		≤ 500 Ohm
Insulation voltage 1.)	1000 VAC @ 50 Hz, 1 min		
Insulation resistance 1.)	2 MOhm @ 500 VDC, 1 min		
MTTF (EN29500-2005-1)	1173a	965a	379a

1.) According IEC 60393

Wire colour/pin assignment

Function:	Option PG(R)	Option M8(R)
OUT	brown	Pin 3
VSUP	red	Pin 1
GND	black	Pin 4

Plug M8 (R) – pin assignment for 3-pin connector

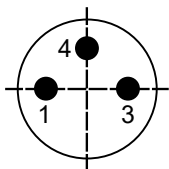

Pin-Numbering of socket connector in the encoder housing

The orientation of the connector relative to the encoder housing is not defined and differs from one encoder to the next. When using angled connectors in combination with axial outlet, the orientation of the cable outlet is thus not defined.

If you need a defined orientation of the cable outlet, please choose our housings with radial cable outlet and use straight mating connectors.

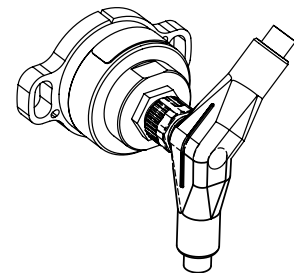

Orientation will vary when using angled connectors.

For details on zero point definition and output programming see page 26.

Order Code HTA25K – singleturn, analogue output, not redundant					
Description	Selection: standard= black/bold , possible options= <i>grey/italic</i>				
Series	HTA25K				
Supply voltage / output signal: VSUP=5 V (4.5 to 5.5 V) / OUT=0 to 5 V (<i>ratiometric</i>) VSUP=24 V (15 to 30 V) / OUT=0 to 10 V VSUP=24 V (9 to 30 V) / OUT=4 to 20 mA VSUP=24 V (9 to 30 V) / OUT=0 to 5 V		0505 2410 2442 2405			
Sense of rotation: (when looking at the shaft, from the front) Clockwise <i>Counterclockwise</i>			CW <i>CCW</i>		
Rotation angle* in [°]: 360 320 270 180 90 <i>Custom rotation angle (≥7°, positive integer)</i>				360 320 270 180 90 XXX	
Electrical connection, cable length: 1 m round cable, axial <i>1 m round cable, radial</i> Plug M8, axial <i>Connector M8, radial</i> <i>Round cable, customer-specific cable length [X,XX m], axial</i> <i>Round cable, customer-specific cable length [X,XX m], radial</i>				PG <i>PGR</i> M8 <i>M8R</i> <i>PGX,XX</i> <i>PGRX,XX</i>	
Installation variant/drilling pattern: Standard version S (Pins for exact alignment optional and not included) <i>Variant P, pins pre-installed on the rotary encoder for precise alignment</i>					S <i>P</i>

* For details see page 26.

Order example HTA25K	
Requirements: VSUP=5 V / OUT=0 to 5 V, sense of rotation CW, rotation angle 360°, round cable 1.00 m, mounting using M4 screws only	
Example for order code: HTA25K 0505 CW360 PG S	

General
Contents
Overview
Voltage/Current
Redundant
PWM
SER(SPI/SSI)
Redundant
Incremental
Multiturn
Drawings
Technical Data
Accessories

Series HTA25KX – singleturn, analogue output, redundant

Key features HTA25KX :

- Independent signal processing. The HTA25KX rotary encoder electronics are based mainly on one Hall IC in which two semiconductor dies independently capture, evaluate and output the measured values
- Supply voltage, signal output and ground are galvanically insulated => separate electrical connections
- Supply voltages: 2 x 5 VDC or 2 x 15 to 30 VDC
- Signal outputs: 2 x 0 to 5 V or 2 x 0 to 10 V

Electrical data HTA25KX – singleturn, analogue output, redundant

Effective electrical angle of rotation 1.)	7° ≤ α ≤ 360° (programmable at factory), ±0.5°	
Independent linearity (best straight line) 1.)	±0.3% @ 360°	
Absolute Linearity 1.)	±0.6% @ 360°	
Output signal	0 to 5 V ratiometric	0 to 10 V
Resolution	12 Bit	
Update rate	200 μs	
Supply voltage	5 V ±10%	15 to 30 V
Power consumption (no load)	≤ 23 mA	
Output load	≥ 5 kOhm	
Insulation voltage 1.)	1000 VAC @ 50 Hz, 1 min	
Insulation resistance 1.)	2 MOhm @ 500 VDC, 1 min	
MTTF (EN29500-2005-1)	613a	202a

1.) According IEC 60393

Cable and pin assignment HTA25KX – singleturn, analogue output, redundant

Function:	Option PG(R)	Option M8(R)
VSUP 1	red	1
OUT 1	brown	2
GND 1	black	3
GND 2	green	4
OUT 2	yellow	5
VSUP 2	orange	6
n/c	-	7
n/c	-	8

Plug M8 (R) – pin assignment for 8-pin connector

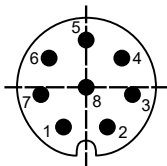

Pin-Numbering of socket connector in the encoder housing

The orientation of the connector relative to the encoder housing is not defined and differs from one encoder to the next. When using angled connectors in combination with axial outlet, the orientation of the cable outlet is thus not defined.

If you need a defined orientation of the cable outlet, please choose our housings with radial cable outlet and use straight mating connectors.

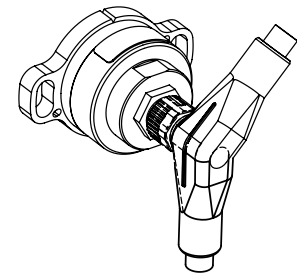

Orientation will vary when using angled connectors.

For details on zero point definition and output programming see page 26.

Order Code HTA25KX – redundant, singleturn, analogue output					
Description	Selection: standard= black/bold , possible options= <i>grey/italic</i>				
Series	HTA25KX				
Supply voltage / output signal: VSUP=5 V (4.5 to 5.5 V) / OUT=0 to 5 V (ratiometric) VSUP=24 V (15 to 30 V) / OUT=0 to 10 V	0505 2410				
Sense of rotation: (when looking at the shaft, from the front) Clockwise/Clockwise (ganging) <i>Clockwise/Counterclockwise (counterrotational)</i>		CW CW <i>CW CCW</i>			
Rotation angle* in [°]: 360 <i>320</i> <i>270</i> <i>180</i> <i>90</i> <i>Custom rotation angle (≥7°, positive integer)</i>			360 <i>320</i> <i>270</i> <i>180</i> <i>90</i> <i>XXX</i>		
Electrical connection, cable length: 1 m round cable, axial <i>1 m round cable, radial</i> Plug M8, axial <i>Connector M8, radial</i> <i>Round cable, customer-specific cable length [X,XX m], axial</i> <i>Round cable, customer-specific cable length [X,XX m], radial</i>				PG <i>PGR</i> M8 <i>M8R</i> <i>PGX,XX</i> <i>PGRX,XX</i>	
Installation variant/drilling pattern: Standard version S (Pins for exact alignment optional and not included) <i>Variant P, pins pre-installed on the rotary encoder for precise alignment</i>					S <i>P</i>

* For details see page 26.

Order example HTA25KX – redundant, singleturn, analogue output	
Requirement: Redundant, VSUP=5 V /OUT=0...5 V, signal 1 sense of rotation CW, signal 2 sense of rotation CW, electrical rotation 360° signal 1 and 2, M8 plug radial, 8 pin, installation type P (drilling pattern P)	
Example for order code: HTA25KX 0505 CW CW 360 M8R P	

- General
- Contents
- Overview
- Voltage/Current
- Redundant
- Analogue (HTA25K)
- PWM (HTP25K)
- SER(SPI/SSI)
- Serial (HTS25K)
- Redundant
- Serial
- Incremental (HTI25K)
- Multiturn HTA25KPM
- Drawings
- Technical Data
- Accessories

Series HTP25K – singleturn, PWM output, not redundant

Key features HTP25K:

- PWM signal output
- Frequency 244 Hz (constant)
- Pulse width (duty cycle) 10% (0°) to 90% (360°)
- Supply voltage: 5 VDC +/-10%



Electrical data HTP25K – singleturn, PWM output, not redundant

Effective electrical angle of rotation 1.)	$7^\circ \leq \alpha \leq 360^\circ$ (programmable in factory), $\pm 0.5^\circ$
Independent linearity (best straight line) 1.)	$\pm 0.4\%$ @ 360°
Absolute Linearity 1.)	$\pm 0.6\%$ @ 360°
Output signal	PWM (pulse width modulation)
Output signal voltage	5 V
Carrier frequency	244 Hz (constant)
Minimum duty cycle	10%, equal to app. 0.4 ms
Maximum duty cycle	90%, equal to app. 3.5 ms
Resolution	12 Bit
Supply voltage	5 V $\pm 10\%$
Power consumption (no load)	≤ 10 mA
Output load	≥ 5 kOhm
Insulation voltage 1.)	1000 VAC @ 50 Hz, 1 min
Insulation resistance 1.)	2 MOhm @ 500 VDC, 1 min
MTTF (EN29500-2005-1)	1267a

1.) According IEC 60393

Function description PWM signal output HTP25K

The HTP25K provides a constant carrier frequency with 244 Hz at the signal output, with HIGH and LOW signal levels which have a constant signal amplitude. A constant carrier frequency means a constant length of the period duration. The duty cycle and thus the pulse width changes in dependency of the rotating angle between 10% to 90% relative to the signal period. If the CW option is selected, the duty cycle increases clockwise when turning the shaft clockwise. If the CCW option is selected, the duty cycle decreases clockwise if the shaft is turned clockwise. Normally no signal conversion is required for further processing of the output signal, because many μ Controllers already have an input for PWM signals.

Order Code HTP25K – singleturn, PWM output, not redundant					
Description	Selection: standard= black/bold , possible options= <i>grey/italic</i>				
Series	HTP25K				
Supply voltage / output signal: VSUP=5 V (4.5 to 5.5 V) / OUT=5 V / 244 Hz / PWM 10-90%	5PWM				
Sense of rotation: (when looking at the shaft, from the front) Clockwise <i>Counterclockwise</i>		CW <i>CCW</i>			
Rotation angle* in [°]: 360 320 270 180 90 <i>Custom rotation angle (≥7°, positive integer)</i>			360 320 270 180 90 XXX		
Electrical connection, cable length: 1 m round cable, axial <i>1 m round cable, radial</i> Plug M8, axial <i>Connector M8, radial</i> <i>Round cable, customer-specific cable length [X,XX m], axial</i> <i>Round cable, customer-specific cable length [X,XX m], radial</i>				PG <i>PGR</i> M8 <i>M8R</i> <i>PGX,XX</i> <i>PGRX,XX</i>	
Installation variant/drilling pattern: Standard version S (Pins for exact alignment optional and not included) <i>Variant P, pins pre-installed on the rotary encoder for precise alignment</i>					S <i>P</i>

* For details see page 26.

Order example HTP25K – singleturn, PWM output, not redundant	
Requirement: Shaft Ø 6.36 mm, shaft length 12 mm, VSUP=5 V / OUT=244 Hz, sense of rotation CW, rotation angle 360°, M8 connector	
Example for order code: HTP25K 6,35x12 5PWM CW 360 M8	

Cable and pin assignment		
Function	Option PG(R)	Option M8(R)
OUT	brown	Pin 3
VSUP	red	Pin 1
GND	black	Pin 4

Plug M8 (R) – pin assignment for 3-pin connector	
<p>Pin-Numbering of socket connector in the encoder housing</p>	<p>The orientation of the connector relative to the encoder housing is not defined and differs from one encoder to the next. When using angled connectors in combination with axial outlet, the orientation of the cable outlet is thus not defined.</p> <p>If you need a defined orientation of the cable outlet, please choose our housings with radial cable outlet and use straight mating connectors.</p>
	<p>Orientation will vary when using angled connectors.</p>

For details on zero point definition and output programming see page 26.

General
Contents
Overview
Voltage/Current
Redundant
Analogue (HTA25K)
PWM (HTP25K)
SER(SPI/SSI)
Serial (HTS25K)
Redundant
Incremental (HTI25K)
Multiturn HTA25KPM
Drawings
Technical Data
Accessories

Series HTS25K – singleturn, digital output, not redundant

Key features HTS25K:

- SSI, SPI or SER interface
- SSI interface: Option UVW signal output for motor commutation of DC motors selectable from 1 to 16 pole pairs
- SPI, SER interfaces: Signal transmission only possible via short signal cables
- Supply voltage SSI: 24 VDC (9 to 30 V), SER and SPI: 5 VDC +/-10%



Electrical data HTS25K – singleturn, digital output, not redundant

Output signal	SER	SPI	SSI
Effective electrical angle of rotation 1.)		360°	
Independent linearity (best straight line) 1.)	±0,4% @ 360°		±0,3% @ 360°
Absolute linearity 1.)	±0,8% @ 360°		±0,6% @ 360°
UVW signal outputs for motor commutation	NO	NO	YES (option)
Amount of pole pairs (UVW)	-	-	1 to 16
Resolution	12 Bit	14 Bit	12 Bit
Update rate	96 µs	200 µs	100 µs
Supply voltage	5 VDC ±10 %		24 VDC (9 to 30 V)
Power consumption (no load)	≤ 14 mA	≤ 12 mA	≤ 20 mA
Insulation voltage 1.)	1000 VAC @ 50 Hz, 1 min		
Insulation resistance 1.)	2 MOhm @ 500 VDC, 1 min		
MTTF (EN29500-2005-1)	1267a	2046a	535a

1.) According IEC 60393

For details on zero point definition and output programming see page 26.

Order Code HTS25K – singleturn, digital output, not redundant			
Description	Selection: standard= black/bold , possible options= <i>grey/italic</i>		
Series	HTS25K		
Supply voltage / output signal: 24 VDC (9 to 30 V) / SSI (12 Bit) 5 VDC ± 10% / SPI (14 Bit) 5 VDC ± 10% / SER (12 Bit) (no zero point definition possible)		24SSI 05SPI 05SER	
Electrical connection, cable length: 1 m round cable, axial <i>1 m round cable, radial</i> Plug M8, axial <i>Connector M8, radial</i> <i>Round cable, customer-specific cable length [X,XX m], axial</i> <i>Round cable, customer-specific cable length [X,XX m], radial</i>		PG <i>PGR</i> M8 <i>M8R</i> <i>PGX,XX</i> <i>PGRX,XX</i>	
Installation variant/drilling pattern: Standard version S (Pins for exact alignment optional and not included) <i>Variant P, pins pre-installed on the rotary encoder for precise alignment</i>			S <i>P</i>

Order example HTS25K – singleturn, digital output, not redundant
Requirement: Shaft Ø 6.00 mm, shaft length 12 mm, 14 Bit/5 VDC/SPI, round cable 1 m, radial
Example for order code: HTS25K 6x12 05SPI PGR

Order example HTS25K singleturn, serial output, not redundant
Requirements: Standard shaft Ø 6,00 mm, electronics 12 Bit/24 VDC/SSI, round cable 1 m
Example for order code: HTS25K 6x12 24SSI PG

**Please pay attention to the limiting factors in the cable lengths / transmission limits of the serial communication.
Baud rate/clock frequency must be adjusted to account for cable length/transmission issues.**

Cable and pin assignment for option 05SPI, not redundant

Function:	Option PG(R), round signal cable	Option M8(R), 8 pin
VSUP	red	1
GND	black	2
CS, MOSI	yellow	3
CLK	green	4
DATA	orange	5
-	brown n/c	6 n/c
-	-	7 n/c
-	-	8 n/c

Cable and pin assignment for option 05SER

Function:	Option PG(R), round signal cable	Option M8(R), 8 pin
VSUP	red	1
Ground (GND)	black	2
Chipselect (CSN)	yellow	3
Clock (CLK)	green	4
Data out (DO)	orange	5
-	brown n/c	6 n/c
-	-	7 n/c
-	-	8 n/c

Cable and pin assignment for option SSI interface

Function:	Option PG(R), round signal cable	Option M8(R), 8 pin
GND	black	1
VSUP	red	2
CLK+	brown	3
CLK-	orange	4
DATA+	yellow	5
DATA-	green	6
-	-	7 n/c
-	-	8 n/c

Plug M8 (R) – pin assignment for 8-pin connectors

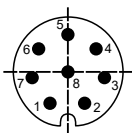
 8 pin
SPI, SER, SSI

Pin-Numbering of socket connector in the encoder housing

The orientation of the connector relative to the encoder housing is not defined and differs from one encoder to the next. When using angled connectors in combination with axial outlet, the orientation of the cable outlet is thus not defined.

If you need a defined orientation of the cable outlet, please choose our housings with radial cable outlet and use straight mating connectors.

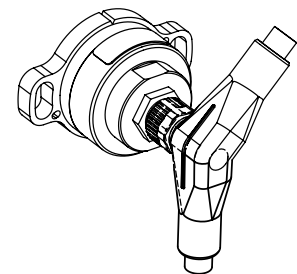

Orientation will vary when using angled connectors.

Series HTS25KX – singleturn, SPI output, redundant

Key features HTS25KX:

- Independent signal processing. The HTS25KX rotary encoder electronics are based on one Hall IC in which two semiconductor elements independently capture, evaluate and output measured values
- Supply voltage, signal output and ground are galvanically insulated => separate electrical connections
- Supply voltage: 2 x 5 VDC ±10%
- Signal output: 2 x SPI

Electrical data HTS25KX – singleturn, SPI output, redundant

Effective electrical angle of rotation 1.)	360°
Sense of rotation (when looking at the shaft, from the front)	Clockwise/clockwise (ganging)
Independent linearity (best straight line) 1.)	±0.4% @ 360°
Absolute linearity 1.)	±0.8% @ 360°
Output signal	SPI
Resolution	14 Bit
Update rate	200 µs
Supply voltage	5 VDC ±10%
Power consumption (no load)	≤ 24 mA
Insulation voltage 1.)	1000 VAC @ 50 Hz, 1 min
Insulation resistance 1.)	2 MOhm @ 500 VDC, 1 min
MTTF (EN29500-2005-1)	2046a

1.) According IEC 60393

Cable and pin assignment HTS25KX

Function:	Option PG(R), round signal cable	Option M8(R), 12 pin
VDD 1	red	1
GND 1	black	2
MOSI 1	yellow	3
SCLK 1	green	4
SS 1	orange	5
VDD 2	white	6
GND 2	blue	7
MOSI 2	violet	8
SCLK 2	brown	9
SS 2	grey	10
-	-	11 n/c
-	-	12 n/c

For details on zero point definition and output programming see page 26.

Order Code HTS25KX – redundant, singleturn, digital output			
Description	Selection: standard= black/bold , possible options= <i>grey/italic</i>		
Series	HTS25KX		
Supply voltage / output signal: 5 VDC ± 10% / SPI (14 Bit), redundant		05SPI	
Electrical connection, cable length: 1 m round cable, axial <i>1 m round cable, radial</i> Plug M8, axial <i>Connector M8, radial</i> <i>Round cable, customer-specific cable length [X,XX m], axial</i> <i>Round cable, customer-specific cable length [X,XX m], radial</i>			PG <i>PGR</i> M8 <i>M8R</i> <i>PGX,XX</i> <i>PGRX,XX</i>
Installation variant/drilling pattern: Standard version S (Pins for exact alignment optional and not included) <i>Variant P, pins pre-installed on the rotary encoder for precise alignment</i>			S <i>P</i>

Order example HTS25KX	
Specifications: Shaft Ø 6.00 mm, shaft length 12 mm, 14 Bit/5 VDC/SPI, M8 connector, radial	
Example for order code: HTS25KX 6x12 05SPI M8R	

Please pay attention to the limiting factors in the cable lengths / transmission limits of the serial communication.
Baud rate/clock frequency must be adjusted to account for cable length/transmission issues.

Plug M8 – pin assignment for 12-pin connector

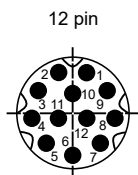

Pin-Numbering of socket connector in the encoder housing

The orientation of the connector relative to the encoder housing is not defined and differs from one encoder to the next. When using angled connectors in combination with axial outlet, the orientation of the cable outlet is thus not defined.

If you need a defined orientation of the cable outlet, please choose our housings with radial cable outlet and use straight mating connectors.

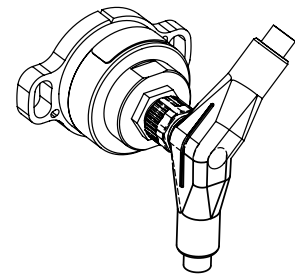

Orientation will vary when using angled connectors.

Series HTI25K – singleturn, incremental output, not redundant

Key features HTI25K:

- Channels: A, B and index signal Z. Option differential signal output A, A/, B, B/, Z, Z/
- UVW signal output for motor commutation of DC-motors selectable from 1 to 16 pole pairs
- TTL, Push Pull or Open Collector electronics
- Maximum number of pulses per channel 1024 pulses per revolution (4096 steps)
- Option: ex works programmable number of pulses from 1 to 1024 pulses per revolution in one pulse step width



Electrical data HTI25K – singleturn, incremental output, not redundant

Output Signal	TTL	Push-Pull	Open Collector
Number of pulses	1 to 1024 ppr		1 to 360 ppr
Differential signal output (A, A/, B, B/, Z, Z/)	optional		no
Limit frequency	100 kHz		10 kHz
Switch-on delay	20 ms		
Supply voltage	5 VDC ±10%	10 to 30 V	10 to 30 V
Power consumption (no load)	≤ 15 mA	≤ 50 mA	≤ 25 mA
Output load	≥ 5 kOhm		
Max. pull-up voltage	-		30 VDC
Insulation voltage 1.)	1000 VAC @ 50 Hz, 1 min		
Insulation resistance 1.)	2 MOhm @ 500 VDC, 1 min		
MTTF (EN29500-2005-1)	473a	462a	570a

1.) According to IEC 60393

Output circuit HTI25K per channel

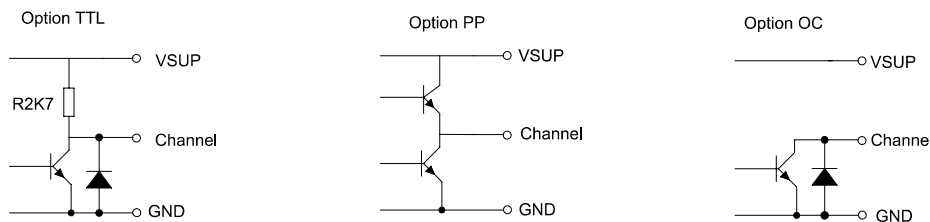

For details on zero point definition and output programming see page 26.

Order Code HTI25K – singleturn, incremental output				
Description	Selection: standard= black/bold , possible options= <i>grey/italic</i>			
Series	HTI25K			
Number of pulses (ppr):				
32		32		
64		64		
128		128		
256		256		
512 <i>(only for TTL and push-pull)</i>		512		
1024 <i>(only for TTL and push-pull)</i>		1024		
<i>User-defined number of pulses 1 to 1024, step-width 1 pulse</i>		<i>0XXX</i>		
<i>(>360 pulses only for TTL and Push-Pull)</i>				
Supply voltage / output signal:				
VSUP=24 V (10 to 30 V) / OUT=push-pull A, B, Z			24BZPP	
VSUP=5 V ± 10% / OUT=TTL A, B, Z			05BZTTL	
VSUP=24 V (10 to 30 V) / OUT=open collector A, B, Z			24BZOC	
Electrical connection, cable length:				
1 m round cable, axial				
<i>1 m round cable, radial</i>				
Plug M8, axial				
<i>Connector M8, radial</i>				
<i>Round cable, customer-specific cable length [X,XX m], axial</i>				
<i>Round cable, customer-specific cable length [X,XX m], radial</i>				
Installation variant/drilling pattern:				
Standard version S <i>(Pins for exact alignment optional and not included)</i>				S
<i>Variant P, pins pre-installed on the rotary encoder for precise alignment</i>				<i>P</i>

Order example HTI25K – singleturn, incremental output	
Requirement:	Shaft Ø 6.00 mm, shaft length 12 mm, number of pulses 1024 TTL output, VSUP=5 V/TTL, round cable 1 m
Example for order code:	HTA25K 6x12 1024 05BZTTL PG

Cable and pin assignments – options 24BZPP, 05BZTTL and 24BZOC			
Option M8(R), 8 pin		Option PG(R), round cable	
Pin-No.	Function	Wire colour	Function
Pin 1	VSUP	red	VSUP
Pin 2	GND	black	GND
Pin 3	A	brown	A
Pin 4	B	orange	B
Pin 5	Z	yellow	Z
Pin 6	n/c	green	n/c
Pin 7	n/c		
Pin 8	n/c		

Plug M8 – pin assignment for 8-pin connectors

Pin-Numbering of socket connector in the encoder housing

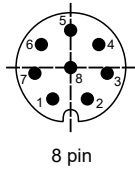

The orientation of the connector relative to the encoder housing is not defined and differs from one encoder to the next. When using angled connectors in combination with axial outlet, the orientation of the cable outlet is thus not defined.

If you need a defined orientation of the cable outlet, please choose our housings with radial cable outlet and use straight mating connectors.

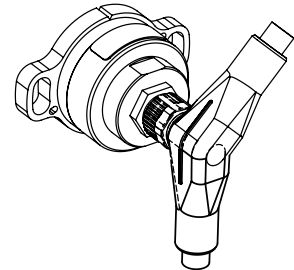

Orientation will vary when using angled connectors.

Signal details

Incremental signal output pattern:

A, B, Z (Standard)

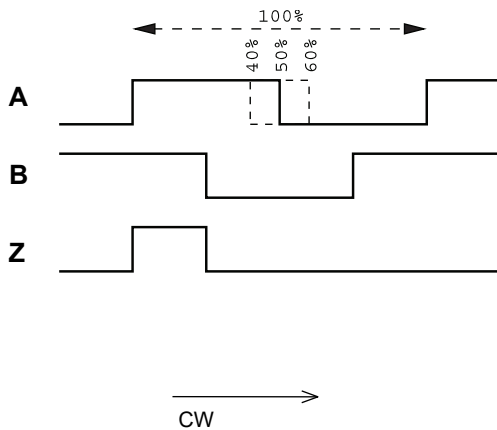

Option differential signal output
A, A/, B B/, Z Z/

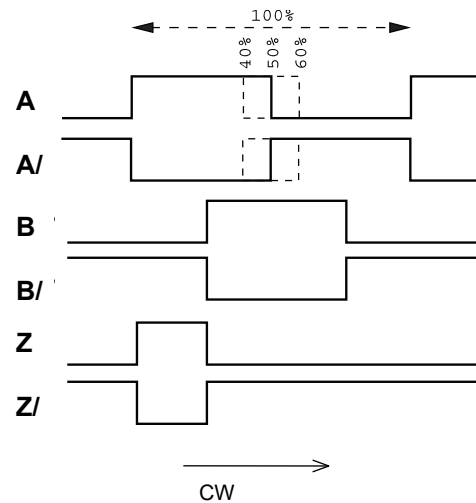

The percentage information describes the proportion of a pulse in dependency to the duration of one period

General
Contents
Overview
Voltage/Current
Redundant Analogue (HTA25K)
PWM (HTP25K)
SER(SPI/SSI) Serial (HTS25K)
Redundant Serial (HTS25K)
Incremental (HTI25K)
Multiturn HTA25KPM
Drawings
Technical Data
Accessories

Series HTA25KPM – multi-/singleturn, programmable, analogue output, not redundant

Key features HTA25KPM :

- Measuring range 10° to max. 72000° (200 shaft revolutions)
- Programmable by the user. Programmable are the sense of rotation (CW/CCW) and the effective electrical angle [°]
- Programmable up to 10000 times
- Can also be used as a programmable singleturn rotary encoder
- Maximum rotation of the shaft in a voltage-free state without loss of the angle information +/-179°
- Factory programming (ex works): effective electrical angle of rotation 3600° (10 shaft revolutions), sense rotation CW
- Supply voltage: 9 to 30 VDC, 15 to 30 VDC
- Output signal: 4 to 20 mA, 0 to 5 V, 0 to 10 V



Electrical data HTA25KPM – multi-/singleturn, programmable, analogue output, not redundant

Effective electrical angle of rotation 1.)	0 to 10° - 0 to 72000° (max. 200 turns) Start point, endpoint and sense of rotation programmable by the customer. Ex works the angle is set to 3600°. For detecting absolute position >360° the sensor should not be turned more than ±179° without supply voltage.		
Independent linearity (best straight line) 1.)	±0.05% @ 3600°		
Absolute Linearity 1.)	±0.1% @ 3600°		
Output signal	0 to 5 V	0 to 10 V	4 to 20 mA
Resolution 1.)	12 Bit		
Update rate	3 ms		
Supply voltage	9 to 30 V	15 to 30 V	11 to 30 V
Power consumption (no load)	< 10 mA		< 14 mA
Output load	≥ 5 kOhm		≤ 500 Ohm
Insulation voltage 1.)	1000 VAC @ 50 Hz, 1 min		
Insulation resistance 1.)	2 MOhm @ 500 VDC, 1 min		
Max. number of programming cycles	10000		
MTTF (EN29500-2005-1)	224a		229a

1.) According IEC 60393

Signal output function (factory programming). Automatic function for inserting signal plateaus

The function represents the relationship between the zero degree marking on the rotary encoder housing in dependency to the 0° position of the shaft and the resulting output signal in the state of delivery, when turning the shaft clockwise (sense of rotation CW). The effective electrical angle of rotation is 3600° ex works. Before and after the linearly rising output signal for 3600° the HTA25KPM integrates automatically signal plateaus for a rotation angle of each 180°.

The following example shows the output signal pattern when actuating the shaft in the delivery state for 11 revolutions clockwise (sense of rotation CW), starting at the 0° position:

1. 10 rotations of the shaft clockwise 0° to 3600°, linearly increasing output signal 0% to 100% FS
2. 1/2 rotation of the shaft 180° (3600° to 3780°) signal plateau 100% FS
3. 1/2 rotation of the shaft 180° (3780° to 3960°) signal plateau 0% FS

The drawing shows the signal-amplitude function for 0 to 10 V signal output

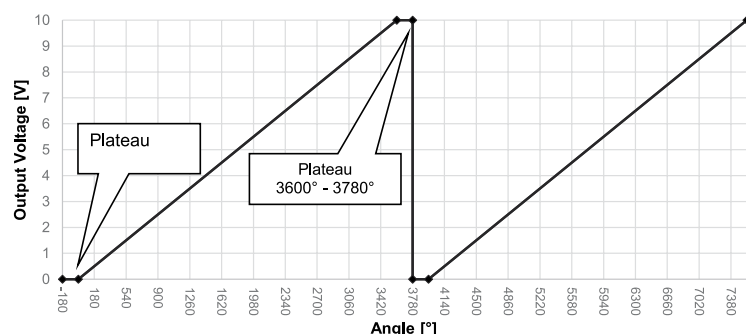

Order Code HTA25KPM – singleturn or multiturn, analogue output, not redundant

Description	Selection: standard= black/bold , possible options= <i>grey/italic</i>		
Series	HTA25KPM		
Supply voltage / output signal: VSUP = 24 V (15 to 30 V) / OUT = 0 to 10 V VSUP = 24 V (9 to 30 V) / OUT = 4 to 20 mA VSUP = 24 V (9 to 30 V) / OUT = 0 to 5 V		2410 2442 2405	
Electrical connection, cable length: 1 m round cable, axial <i>1 m round cable, radial</i> Plug M8, axial <i>Connector M8, radial</i> <i>Round cable, customer-specific cable length [X,XX m], axial</i> <i>Round cable, customer-specific cable length [X,XX m], radial</i>			PG <i>PGR</i> M8 <i>M8R</i> <i>PGX,XX</i> <i>PGRX,XX</i>
Installation variant/drilling pattern: Standard version S (Pins for exact alignment optional and not included) <i>Variant P, pins pre-installed on the rotary encoder for precise alignment</i>			S <i>P</i>

Order example HTA25KPM
Requirement:

Shaft Ø 6.00 mm, shaft length 12 mm, VSUP=24 V / OUT=0 to 5 V, sense of rotation CW, rotation angle ex works 3600° (can be programmed by customer), round cable 1 m radial

Example for order code:

HTA25KPM 6x12 2405 PGR

Cable and pin assignment

Function	Roundcable (Option R)	Option M8(R), 8 pin
DIR	orange	Pin 1
END	green	Pin 2
START	yellow	Pin 3
VSUP	red	Pin 4
OUT	brown	Pin 5
GND	black	Pin 6
-	-	Pin 7 n/c
-	-	Pin 8 n/c

For details on output programming see page 26.

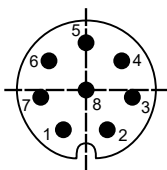
Plug M8(R) – pin assignment for 8-pin connector

Pin-Numbering of socket connector in the encoder housing

The orientation of the connector relative to the encoder housing is not defined and differs from one encoder to the next. When using angled connectors in combination with axial outlet, the orientation of the cable outlet is thus not defined.

If you need a defined orientation of the cable outlet, please choose our housings with radial cable outlet and use straight mating connectors.

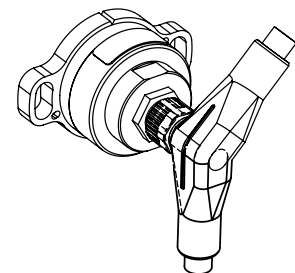

Orientation will vary when using angled connectors.

Order example HTA25KPM programmer

Key features HTA25KPM programmer:

- Programmable measuring range from 10° to max. 72000° (200 shaft revolutions)
- Programmable: sense of rotation (CW/CCW), effective electrical angle [°]
- Up to 10.000 programming cycles per rotary encoder

Order number:

135945

Order code:

Programmer Tool for ETA HTA PM

Programming of HTA25KPM

The programming guide is available for download on the MEGATRON web page <https://www.megatron.de/>

To program the HTA25KPM rotary encoder either the following circuit must be built, or the programmer must be ordered from MEGATRON.

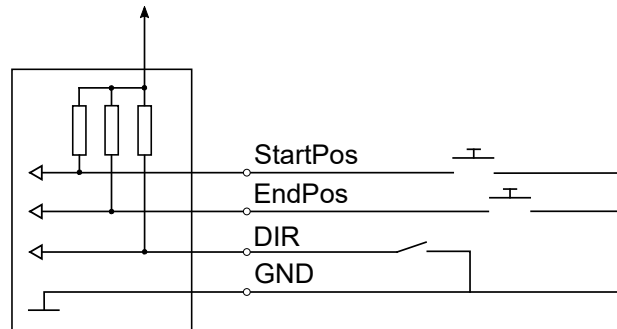

Drawings HTx25K – Drilling patterns S and P

Dimensions Sensor head for Version with drilling pattern S
(pins optional, to be set by customer)

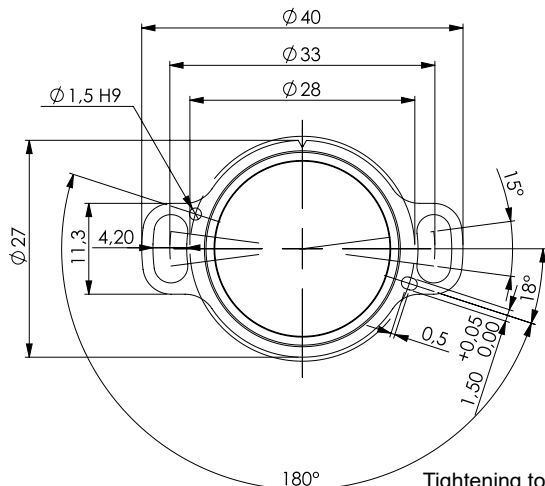

Bohrbild S

Deviations of variant with drilling pattern P
(cylindrical pins part of the rotary encoder)

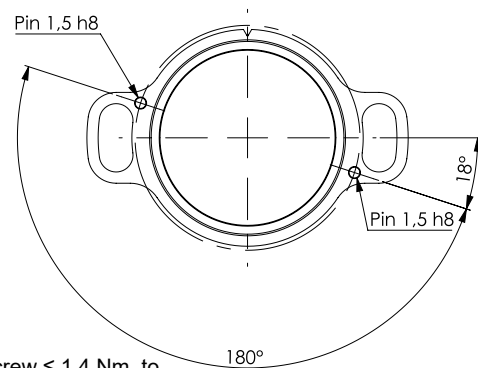

Bohrbild P

Tightening torque of M4 screw ≤ 1.4 Nm, to be locked by medium strength threadlocking adhesive if required

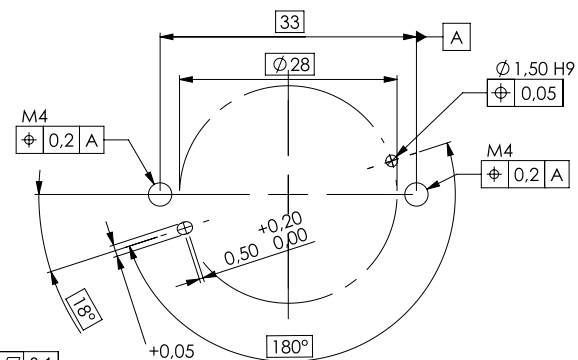
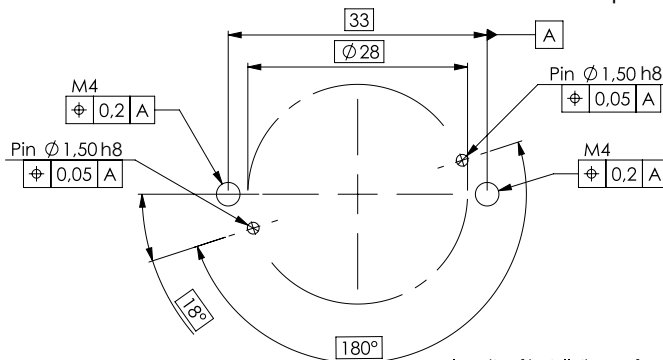

planarity of installation surface $\square 0,1$
roughness of installation surface $\sqrt{Ra 6,3}$

Alle dimensions in mm

Accessories – Sealing ring



O-ring, part no. 133324
DIN 3771-22x1-NBR 70

- For sealing between sensor front and mounting surface,
- Not included in delivery, please order separately

All dimensions in mm

General
Contents
Overview
Voltage/Current (HTA25K)
Redundant Analogue (HTA25K)
PWM (HTP25K)
Redundant SER(SPI/SSI) Serial (HTS25K)
Incremental (HTI25K)
Multiturn HTA25KPM
Drawings
Technical Data
Accessories

Drawings HTx25K – Versions for drilling pattern S, magnet positioning

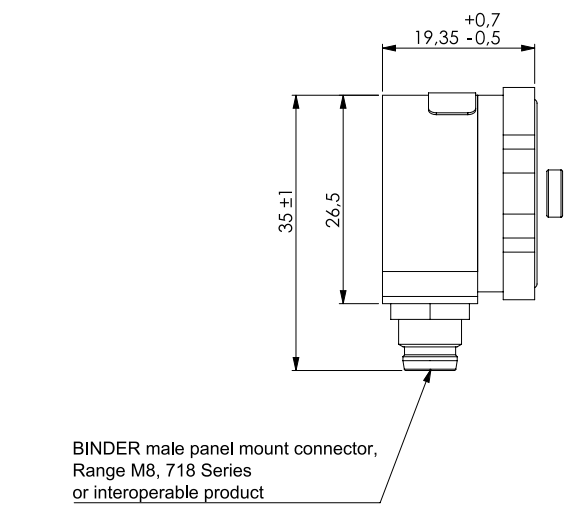
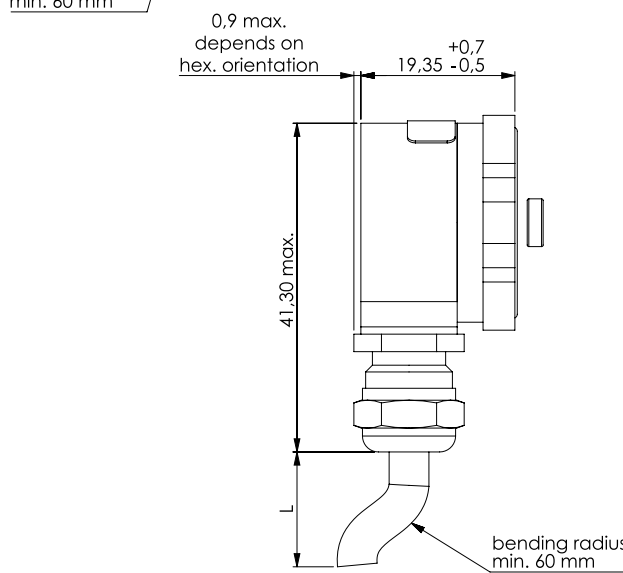
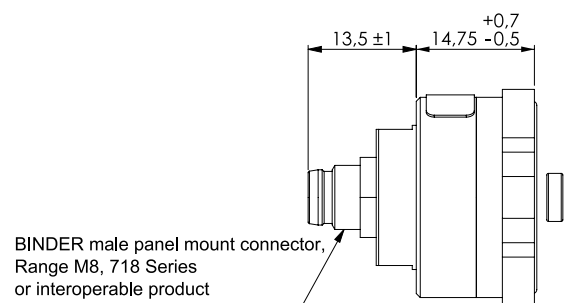
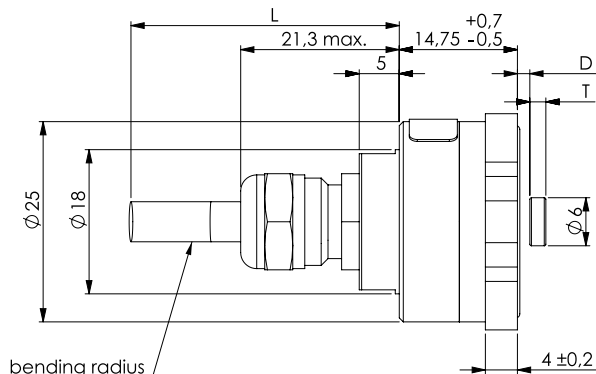

All dimensions in mm

Magnet selection and positioning for enclosed standard NdFeB magnets

Important note:

The correct mounting distance D as well as the correct positioning of the in relation to the central axis to the housing surface of the kiten-coder is mandatory for its correct function. The values below are not valid for other magnets (e. g. accessories).

Magnet thickness and distance from sensor surface		
Electronics	Thickness T of the magnet	Mounting distance D
Analogue singleturn not redundant, HTA25K, HTP25K, HTS25K (only SPI)	3 mm	1.50 +/- 0.15 mm
Serial, not redundant, SPI, (HTS25K)	3 mm	1.50 +/- 0.15 mm
Serial, not redundant, SSI, (HTS25K)	please contact us	
Serial, not redundant, SER, HTS25K (SER)	2 mm	1.00 +/- 0.15 mm
Analogue/serial redundant, HTA25KX, HTS25KX	2.5 mm	0.50 +/- 0.15 mm
Incremental, HTI25K	4 mm	0.50 +/- 0.15 mm
Analogue multi turn HTA25KPM	4 mm	1.00 +/- 0.15 mm

Drawings HTx25K – Deviations for drilling pattern P

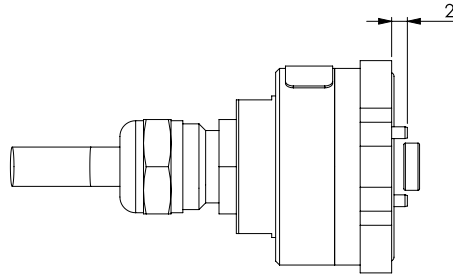

Pins/cylindrical pins are only pre-assembled if drilling hole pattern P is selected.
Missing dimensions see drawings of the variants for hole pattern S.

Drawings – Cable/connector exit direction for radial versions (M8R, PGR)

view shows cable orientation

view shows connector position

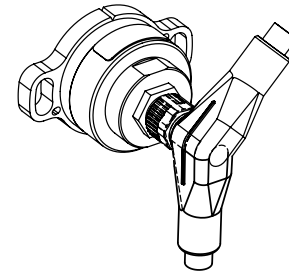
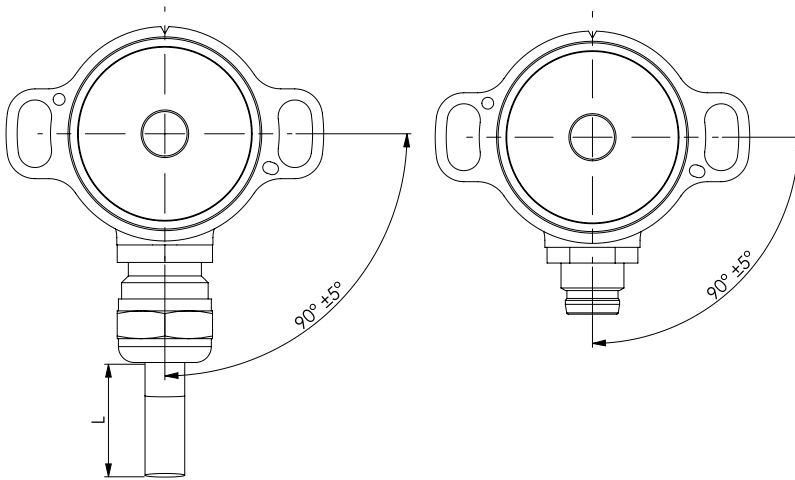

The orientation of the M8 connector pins relative to the encoder housing is not defined and differs from one encoder to the next. When using angled connectors in combination with axial outlet, the orientation of the cable outlet is thus not defined.

If you need a defined orientation of the cable outlet, please choose our housings with radial cable outlet and use straight mating connectors.

Cable specs for option PG(R) (round control cable)

Option	Standard cable length L	Number of single strands (depends on electronics)	Cable sheath Ø or width	Single strands cross section	Allowed tolerance (L)	Minimum bending radius
PG PGR	Standard 1000 mm	3		AWG26	-20 mm to +40 mm	10 x D Ø (D = cable sheath diameter Ø)
		6				
		8				
		10		AWG28		
		12				

Cables delivered with cable shield

(*) Tolerances according IPC Association

Cable length tolerances – custom lengths

Length L	Tolerance
≤ 0.3 m	+25 mm / -20 mm
> 0.3 m - 1.5 m	+40 mm / -20 mm
> 1.5 m - 3 m	+100 mm / -40 mm
> 3 m - 7.5 m	+150 mm / -60 mm

Wire harness length measured from sensor face including connector. Minimum cable length: 0.08 m (for round cable). Please contact us for lengths > 3 m regarding handling and packaging.

Mechanical and Environmental data	
Mechanical angle of rotation 1.)	Endless
Lifetime 2.)	Mechanically unlimited
Max. operational speed (with shaft sealing)	<p>The maximum actuation speed is not limited mechanically. The maximum permissible actuation speed [rev./min] is calculated in relation to the resolution. For absolute encoders:</p> <div style="border: 1px solid black; padding: 5px; width: fit-content; margin: 10px auto;"> $rev./min. (@max. resolution) = \frac{1}{2^{Resolution\ in\ Bit} * Update\ rate\ in\ s} * 60s$ </div> <p>For incremental encoders:</p> <div style="border: 1px solid black; padding: 5px; width: fit-content; margin: 10px auto;"> $Max. rev./min. = \frac{Limit\ Frequency\ \frac{1}{s} * 60s}{Number\ of\ Pulses}$ </div>
Operating temperature range	Option M8 (connector) <ul style="list-style-type: none"> ▪ -30 to +80°C Option PG (cable gland incl. cable) <ul style="list-style-type: none"> ▪ -30 to +85°C cable fixed ▪ -10 to +85°C cable in movement
Storage temperature range	-30 to +105°C
Protection grade (IEC 60529) front side	IP67
Protection grade (IEC 60529) rear side	Option PG: IP68 (cable ends excluded) Option M8: IP67 (when mated with IP67 type M8 cable)
Vibration (DIN EN 60068-2-64:2008 + A1: 2019)	±1.5 mm / 30 g / 10 to 2000 Hz / 16 frequency cycles (3x4 h)
Shock (DIN EN 60068-2-27)	400 m/s ² / 6 ms / half sine (100±5) shocks
Housing diameter	Ø 25 mm
Housing depth	In dependency to the electrical connection position: <ul style="list-style-type: none"> ▪ axial 28.25 mm (variant with M8 connector) ▪ radial 19.35 mm (variant with M8 connector)
Shaft diameter	No limitation (customer side)
Masse (zirka)	HTx25K with connector M8(R), xx g HTx25K with cable gland and 1 m signal cable PG(R), xx g

1.) According IEC 60393

2.) Determined by climatic conditions according to IEC 68-1, para. 5.3.1 without load collectives

Immunity / Electrostatic Discharge / REACH / RoHS	
EN 61000-4-3 RF sine wave	Class A
EN 61000-4-6 Conducted sine wave	Class A
EN 61000-4-8 Power frequency magnetic fields	Class A
EN 61000-4-2 ESD	Class B
REACH Regulation (EC) 1907/2006 including the SVHC list	
RoHS Directive 2011/65/EU	

Mechanical and environmental data, miscellaneous

Sensor mounting	Standard mounting is done by using M4 screws. A rotation of +/- 7.5° is possible to find the zero point in the application when installing the magnet. Alternatively, it is possible to align the rotary encoder exactly to the magnet using cylindrical pins (1.5 mm) in the application (a rotation is then not possible, however). There are two variants/two drilling patterns to choose from: <ul style="list-style-type: none"> ▪ Variant S (standard): Cylindrical pins are installed by the customer in the application and the rotary encoder is attached and fixed using M4 screws ▪ Variant P: Cylindrical pins are pre-installed on the rotary encoder. The drillings for the pins must be implemented on the mounting position in the application. This variant is suitable, for example, for mounting on thin sheet metal.
Mounting hardware included	none (Note: With hole pattern P, the cylinder pins are already fixed on the rotary encoder)
Fastening torque per screw for fastening of the rotary encoder	≤ 1.4 Nm (M4 screws, thread tensile strength class 5.6) For screw securing, the use of a medium-strength thread securing adhesive is recommended
Material shaft	Stainless steel
Material housing	Aluminium
Material cable gland (PG)	Stainless steel
Material connector M8	CuZn nickel-plated

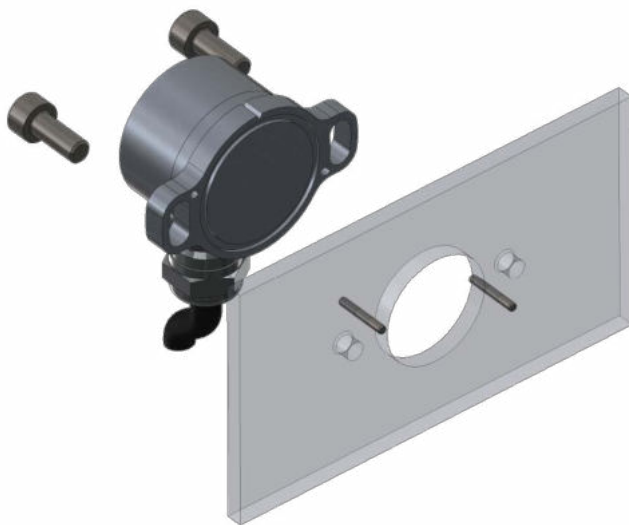

Mounting example of the variant for drilling pattern S
Mount using 2 M4 screws, optional exact alignment using 2 cylindrical pins h8 1.5 (e.g. ISO 2338 B)
(screws and pins not included)

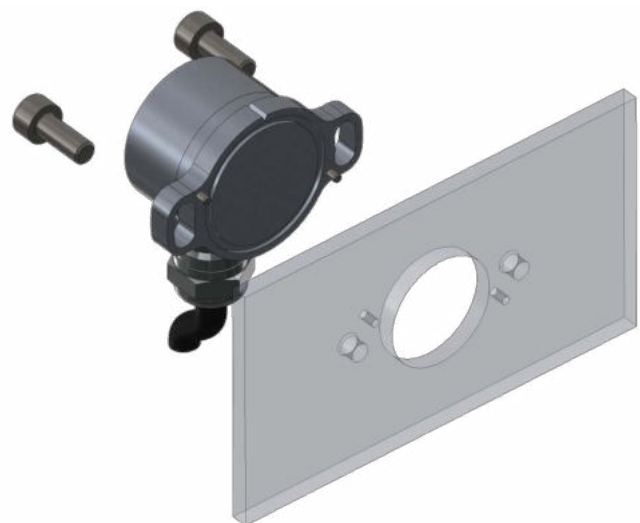

Mounting example of the variant for drilling pattern P:
Mount using 2 M4 screws, exact alignment is ensured using cylindrical pins h8 1.5 pre-assembled at encoder
(screws not included)

Definition of the zero position

Output at the zero point:

HTA25K (analogue outputs): Output signal 0% full scale (F. S.)

HTP25K (PWM output): duty cycle 10% (10% duty cycle)

HTS25K (serial output): Output signal 0% full scale (F. S.), for option 05SER no zero point alignment is available ex works

HTI25K (incremental output): The index signal is output (Z)

The position of the zero position cannot be mechanically defined due to the rotationally symmetrical magnet.
The sense of rotation is defined when looking at the flat front of the rotary encoder:

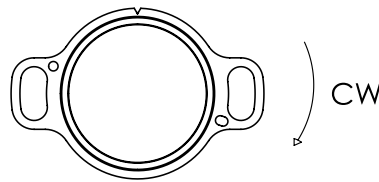

Signal definition for custom rotation angles

Custom angles <math><360^\circ</math>

When programming the electrical angle of rotation of <math><360^\circ</math>, the remaining non-effective range of rotation is divided equally into high and low.

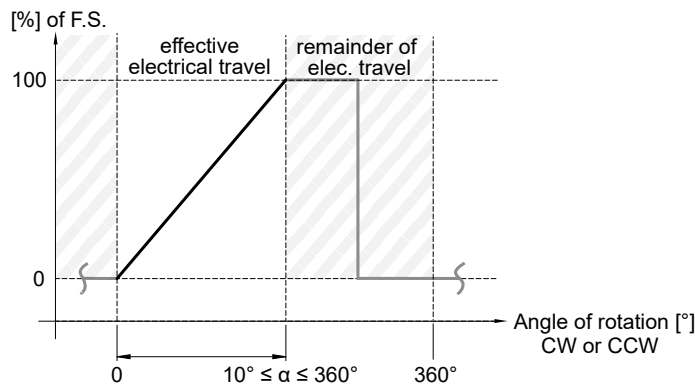

Order Code – Full Overview

>>Please refer to the series sections for details and valid selection criteria

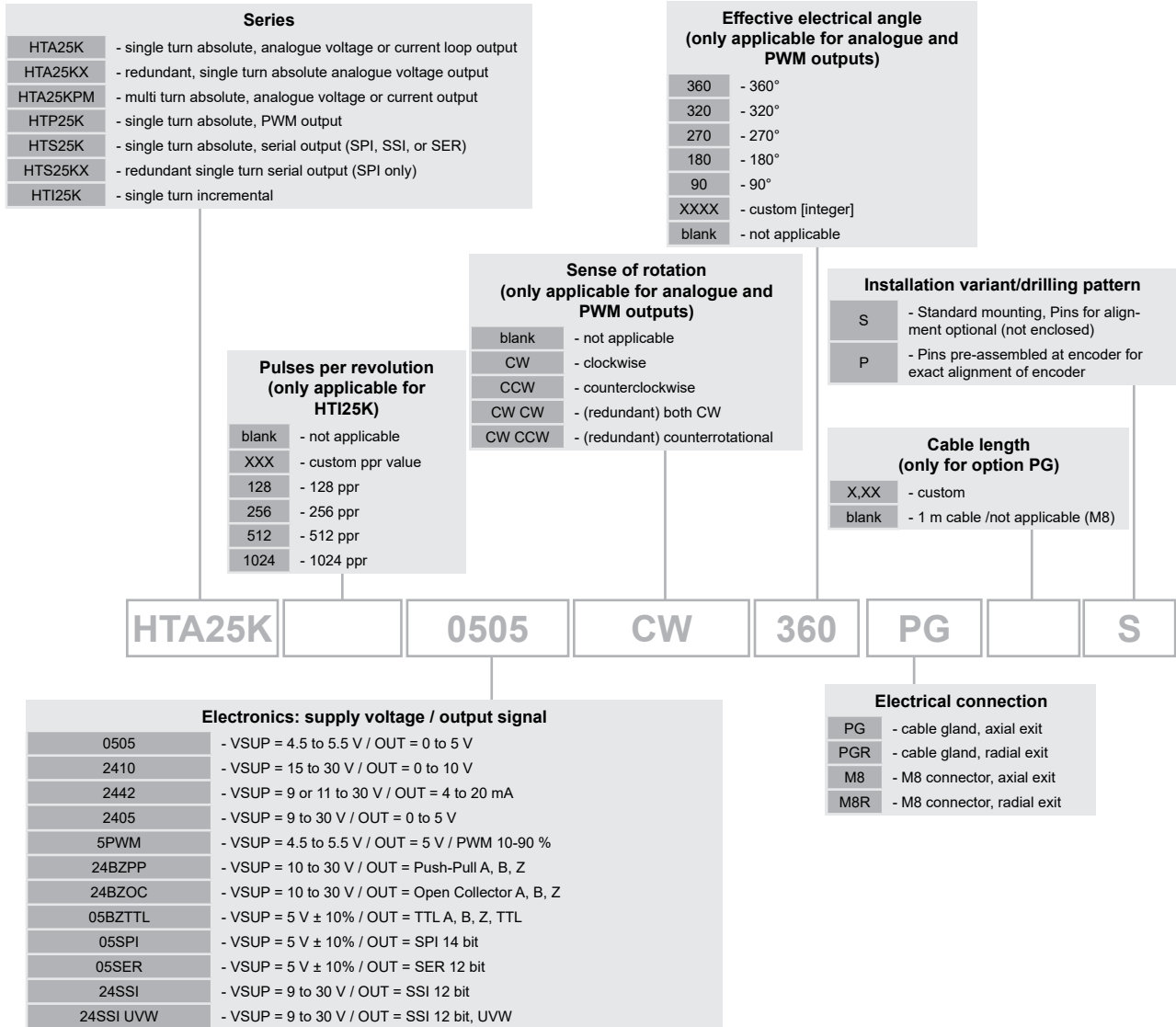

General

Contents

Overview

Voltage/Current

Redundant

PWM (HTP25K)

SER/SPI/SSI

Redundant

Incremental (HTI25K)

Multiturn HTA25KPM

Drawings

Technical Data

Accessories

Counter ICs for incremental encoders

- LS7083 in DIP or SOIC form factor, generates from incremental-signals quadrature-signals
- LS7166 24-Bit counter IC



LS7083/4N-S



LS7166



LS7083/4N

Programmer for programmable encoder HTA25KPM

- For programming of the sense of rotation (CCW/CW)
- For programming of the effective electrical angle of rotation [°]

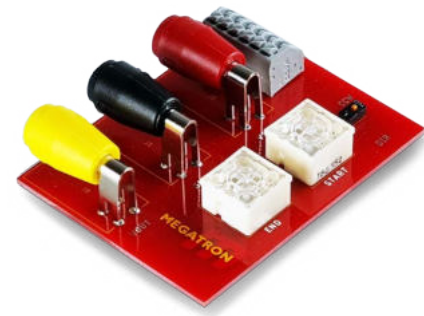

TDS Precision Products GmbH
 Industriestrasse 1a
 CH-8157 Dielsdorf

T + 41 44 885 30 80
 info@tds-pp.com
 www.tds-pp.com

General
Contents
Overview
Voltage/Current
Redundant
Analogue (HTA25K)
PWM
(HTP25K)
SER(SPI/SSI)
(HTS25K)
Redundant
Serial
Incremental
(HTI25K)
Multiturn
HTA25KPM
Drawings
Technical Data
Accessories