

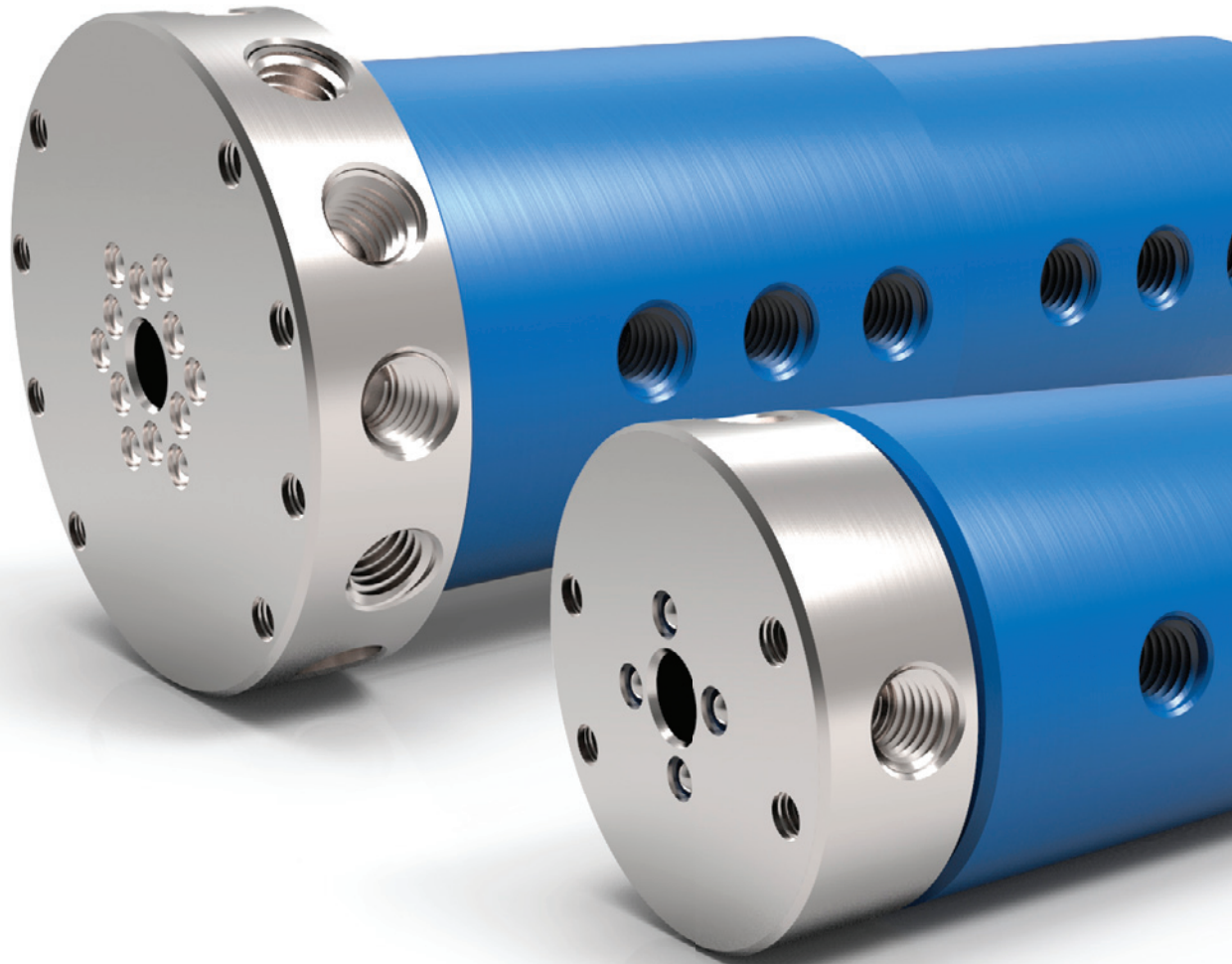

DYNAMIC SEALING TECHNOLOGIES, INC



Lightweight, Compact Rotary Unions

LT Series

FLOW PASSAGE OPTIONS



TDS Precision Products GmbH
Industriestrasse 1a
CH-8157 Dielsdorf

T + 41 44 885 30 80
info@tds-pp.com
www.tds-pp.com



Contents

- 3** What is a Rotary Union?
- 4** Overview
- 5** How To Order
- 7** Specifications & Operating Information
- 8** Performance Data
- 10** LT 2 Passage Dimensions / Optional Equipment
- 12** LT 4 Passage Dimensions / Optional Equipment
- 14** LT 8 Passage Dimensions / Optional Equipment
- 16** LT 12 Passage Dimensions / Optional Equipment
- 18** LT 24 Passage Dimensions / Optional Equipment
- 20** Customer Interface using O-Ring Seal Connection
- 21** Electrical Slip Ring Integration Options
- 22** Installation & Mounting
- 23** Warranty

About DSTI

Dynamic Sealing Technologies, Inc. (DSTI) serves a wide range of global industries as a leader in engineered fluid sealing and transfer solutions for rotating applications.

DSTI core business segments are fluid rotary unions, electrical slip rings, and value-added products and services—providing customers with a single-source solution from design and manufacturing through to testing and qualification—all under one roof. Located in North America and Europe with a team of distribution partners and technical support specialists worldwide.

Learn more at www.dsti.com

What is a Rotary Union?

A rotary union (or swivel joint) is a mechanism used to transfer fluid (under pressure or vacuum) from a stationary inlet to a rotating outlet, preserving and isolating the fluid connection.

Rotary unions are engineered to endure a wide range of temperatures and pressures for a variety of conditions and environments. In addition, rotary unions may integrate multiple passages and handle different types of fluid simultaneously.

See examples at www.dsti.com/industries

HOW DO I CHOOSE THE BEST ROTARY UNION FOR MY APPLICATION?

Tell us about your requirements so we can make a recommendation:

- 1) Type of media(s) / fluid(s) to be transferred
- 2) Number of independent flow channels (passages)
- 3) Operating pressure
- 4) Operating temperature
- 5) Operating speed
- 6) Shaft & housing connection type
- 7) Flow channel (passage) size
- 8) Torque & load requirements
- 9) Duty cycle*

*Does the temperature, speed or pressure fluctuate or change during operation? If so, please provide the detailed ranges for each parameter and time durations of each condition.

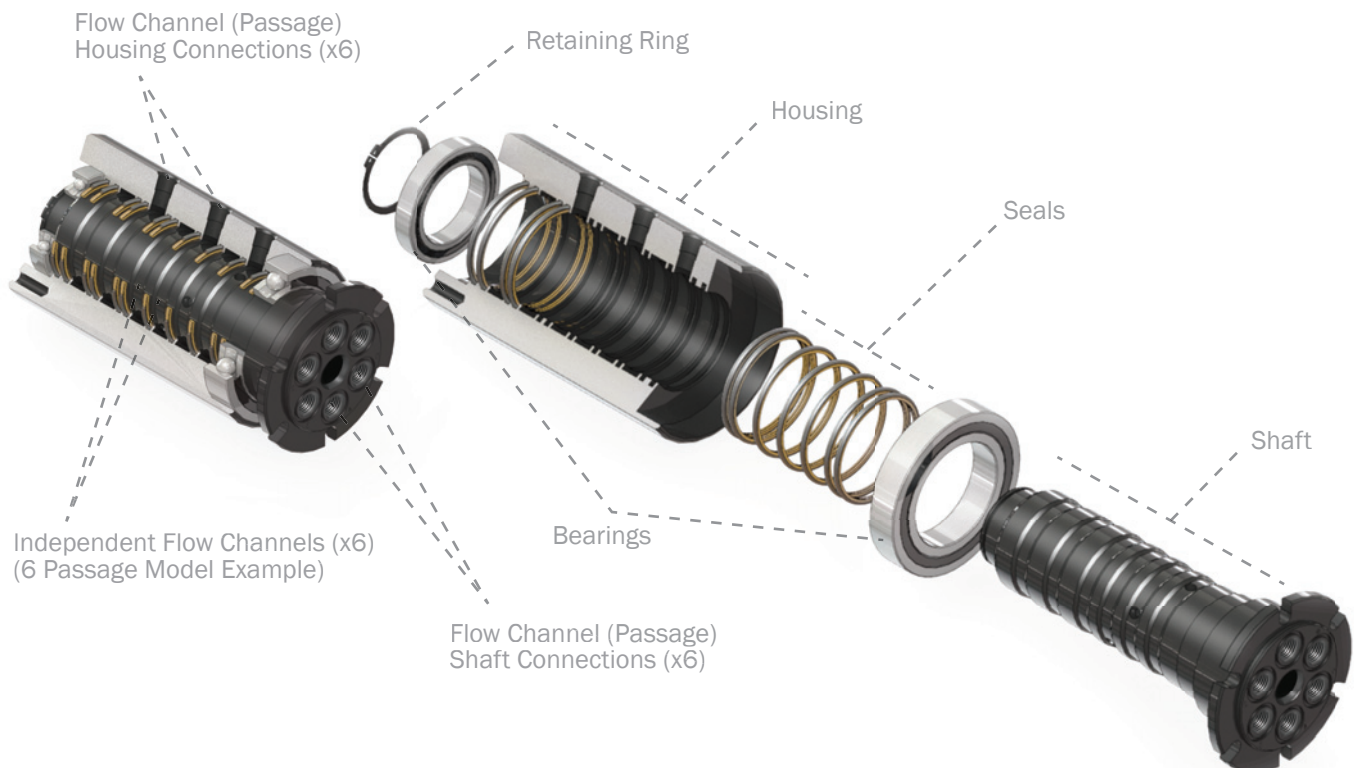

Overview

- + Low Torque Seals
- + Compact Design
- + Lightweight Construction
- + NPT / BSPT / O-Ring Connection Options
- + Low Heat Generation
- + Increased Seal Life Performance
- + Cost-effective Fluid Transfer Solution
- + Custom Modifications Available

Available in 2, 4, 8, 12 and 24 passage models, the LT Series rotary unions are designed for air, gas and vacuum use and are ideal for a number of automation and robotic applications. These lightweight, compact rotary unions feature an all-aluminum construction and independent flow passages capable of transferring different types of media simultaneously.

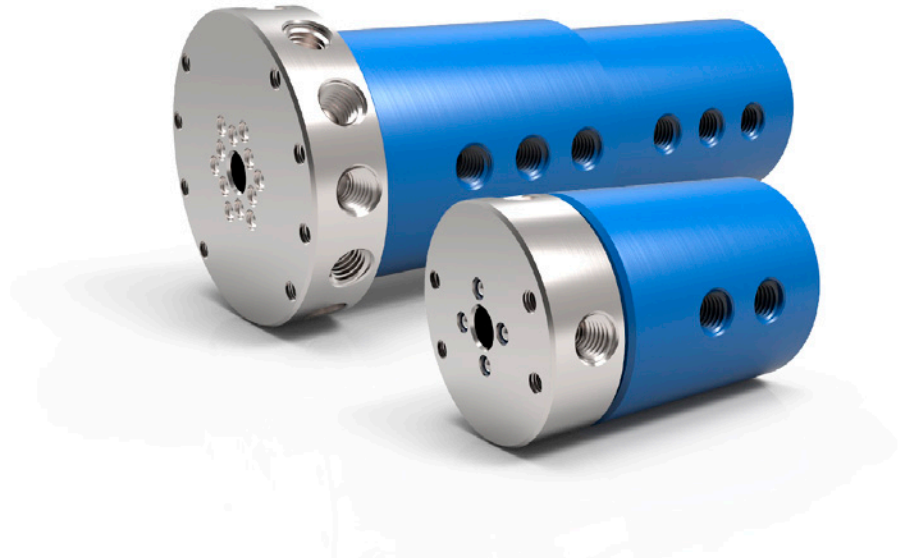

All LT Series models come standard with threaded connections on the sides of the shaft and housing. Models are also available with optional shaft O-ring face seal glands for flush mounting the union to an interface (must be specified when ordering).

How to Order: Create your Part Number



OPTIONS See Next Page

1 With Thru-bore

NOTE
All LT Series rotary unions include thru-bores

- 2** 2 Flow Passages
- 4** 4 Flow Passages
- 8** 8 Flow Passages
- 12** 12 Flow Passages
- 24** 24 Flow Passages

- 1** 1/8" (3.175 mm) Passage Size
- 3** 3/8" (9.525 mm) Passage Size

2 Product Series (LT)

- LT** LT Series (NPT Connection)
- LTM** LTM (Metric) Series (BSPT Connection)

PART NUMBER EXAMPLES

LTM-2181

- LTM 8-Passage, 1/8" BSPT (Metric) Connections

LT-2321

- LT 2-Passage, 3/8" NPT Connections

LT-21121

- LT 12-Passage, 1/8" NPT Connections

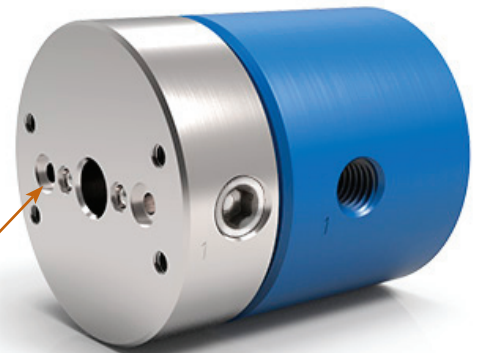

O-RING FACE SEAL GLAND CONNECTIONS

If your application requires flush mounting the rotary union using the face of the shaft, optional O-ring face seal gland connections are available. Please specify "OF" when configuring the part number (see page 6).

How to Order: Choose your Options

LT — 2 — 1 — 2 — 1 — **OF** — **ES12A** — **F2** — **C1**

OF

Add "OF" for Optional Shaft O-ring Face Seal Gland Connections

F1

Housing Mounting Flange

F2

Shaft Mounting Flange

OPTIONAL ELECTRICAL SLIP RINGS¹

ES6A

6 Circuit, 120 Volts

ES12A

12 Circuit, 120 Volts

ESx

6 - 56 Circuits
240 Volts

ESEx

8 - 51 Circuits
240 Volts
Ethernet

ESMx

9 - 52 Circuits
240 Volts

NOTE

(F1) Housing flange required for slip ring assembly

C1

Cover For ES6A / ES12A

C2

Cover For All ES, ESE & ESM

PART NUMBER EXAMPLE

LT-2121-ES6A-C1

- LT 2-Passage, 1/8" NPT Connections, Optional ES6A Electrical Slip Ring w/ (C1) Cover



PART NUMBER EXAMPLE

LT-2121-OF-ES12-F1-F2-C2

- LT 2 Passage, 1/8" NPT Housing Connections, Optional O-ring Face Seal Gland Connections, ES12 Electrical Slip Ring w/ (C2) Cover and Required (F1) Housing Mounting Flange, Additional (F2) Shaft Mounting Flange

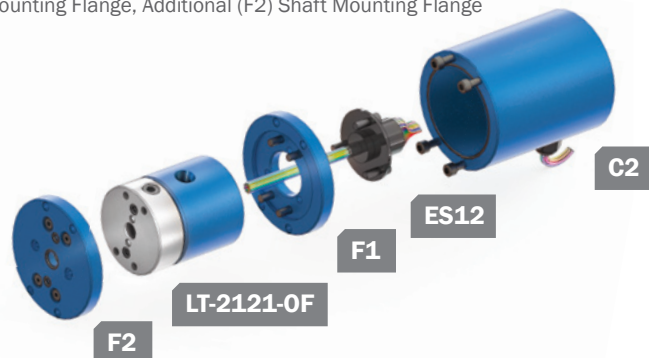

¹ See Electrical Slip Ring Options on page 23 for full specs

Specifications & Operating Information

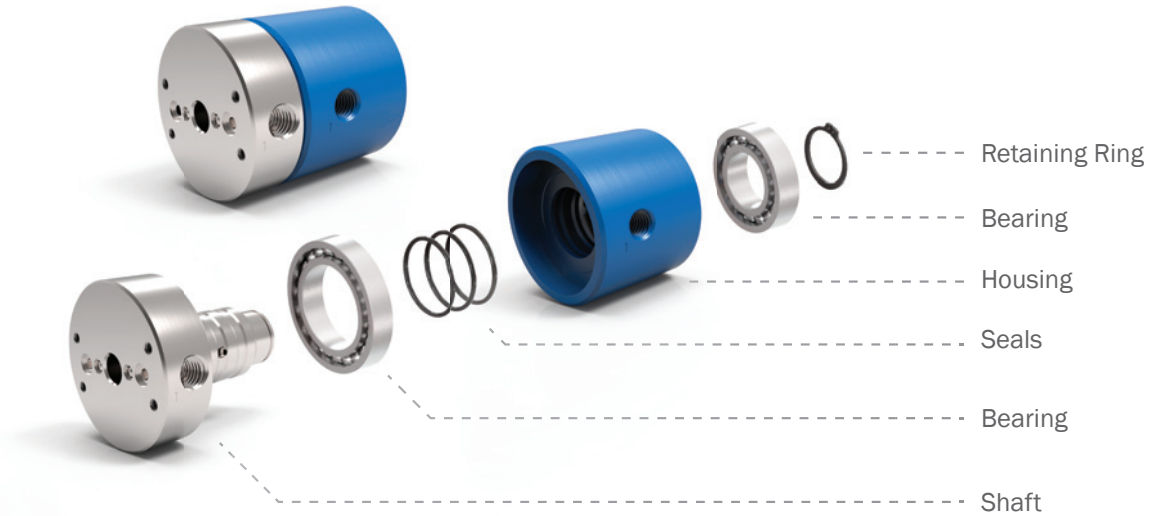

Flow Passage Options	2	4	8	12	24
Media Types	Air/Gas ⁴				
Passage Sizes	1/8" and 3/8" (3.2 mm and 9.5 mm)				
Connection Type	NPT, Rc BSPT, O-ring Face Seals				
Max. Operating Pressure	600 PSI (40 BAR) ¹				
Max. Vacuum	30 HG ¹				
Max. Rotational Speed	500 RPM ²				
Operating Temperature	0° F to 220° F (-18° C to 105° C) ³				
Body Material Type	Aluminum				
Platings and Coatings	Shaft: E-Nickel, Housing: Blue Anodize				
Thru-bore Size	.375" - .440" (9.53 mm - 11.176 mm)				
Slip Ring Options	See Page 20				
Mounting Options	Tapped holes are provided on both the housing and shaft for mounting the assembly.				
Mounting Flange	Optional aluminum flange can be bolted onto the shaft end of the assembly for O-ring face mounting. Optional aluminum housing flange is also available.				

¹ Values are dependent on a combination of all application parameters. Please consult with DSTI.

² Operational life is dependent upon both rotational speed and duty cycle. Contact DSTI if your application requires operating close to the maximum rotational speed with a continuous duty cycle.

³ Applications above 220° F (105° C) require alternative seal materials. Please consult with DSTI.

⁴ The use of liquid media is not recommended for this product. Please select from one of our other product lines or consult DSTI if your application requires use of liquid media.

Performance Data: Pressure vs. Speed (Continuous)

1/8" PASSAGES SERIES

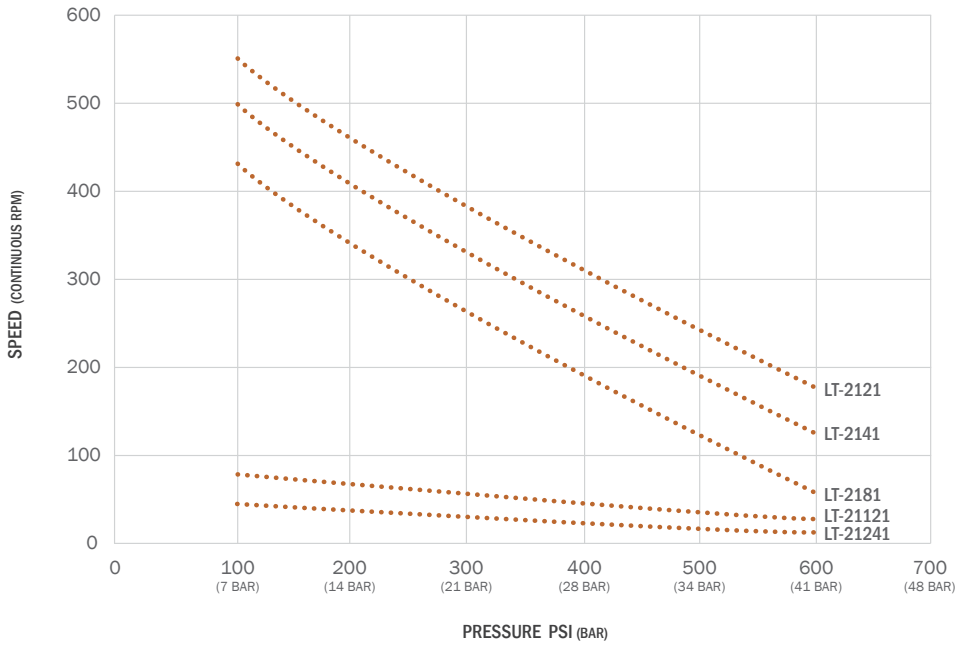

* This data is to be used as a general guideline. Data based on the product rotating continuously. Please consult DSTI about your specific application.

3/8" PASSAGES SERIES

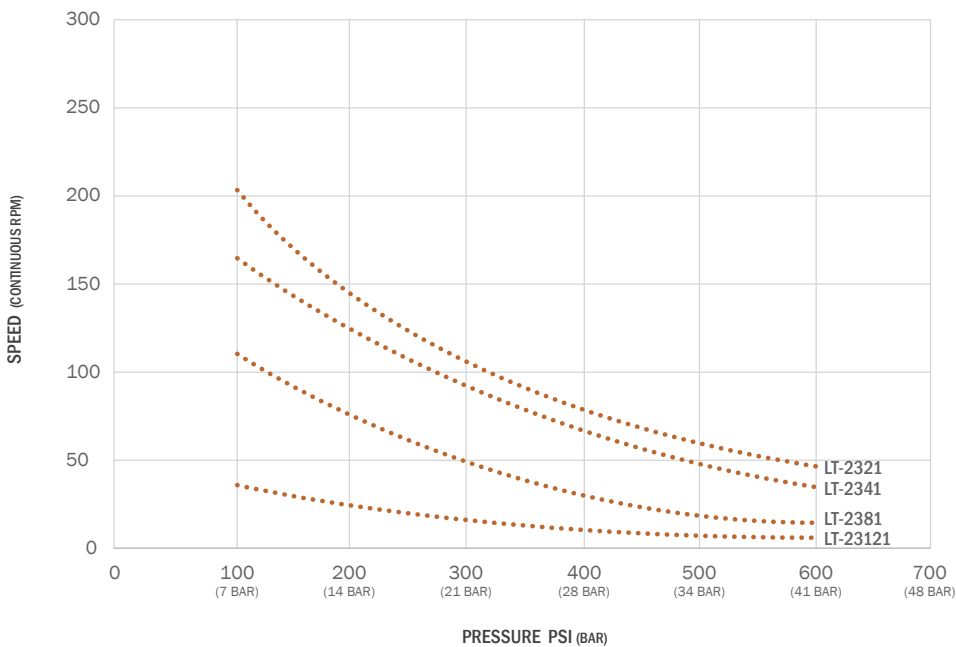

* This data is to be used as a general guideline. Data based on the product rotating continuously. Please consult DSTI about your specific application.

Performance Data: Pressure vs. Torque

1/8" PASSAGES SERIES

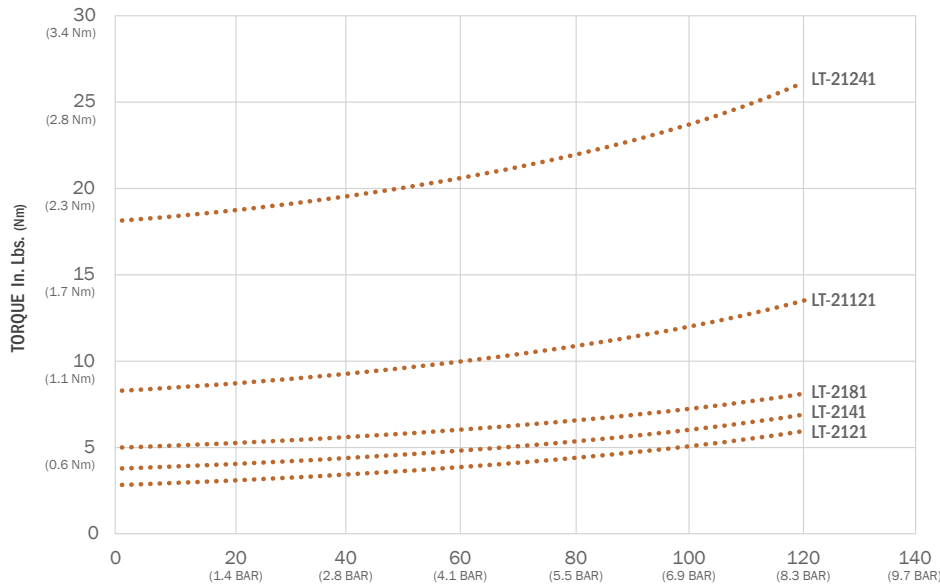

* This data is to be used as a general guideline. Torque data represents the minimum torque required to rotate based on all passages (ports) pressurized with oil/hydraulic media. Required torque to rotate may be greater when using other media types or dry running. For specific torque requirements, please contact DSTI to discuss your application.

3/8" PASSAGES SERIES

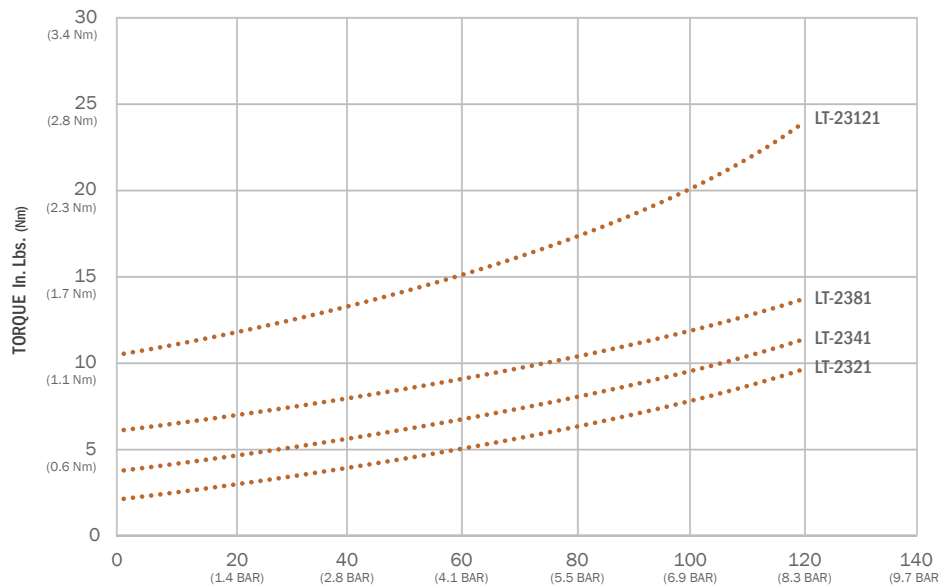

* This data is to be used as a general guideline. Torque data represents the minimum torque required to rotate based on all passages (ports) pressurized with oil/hydraulic media. Required torque to rotate may be greater when using other media types or dry running. For specific torque requirements, please contact DSTI to discuss your application.

2 Flow Passage: Dimensions

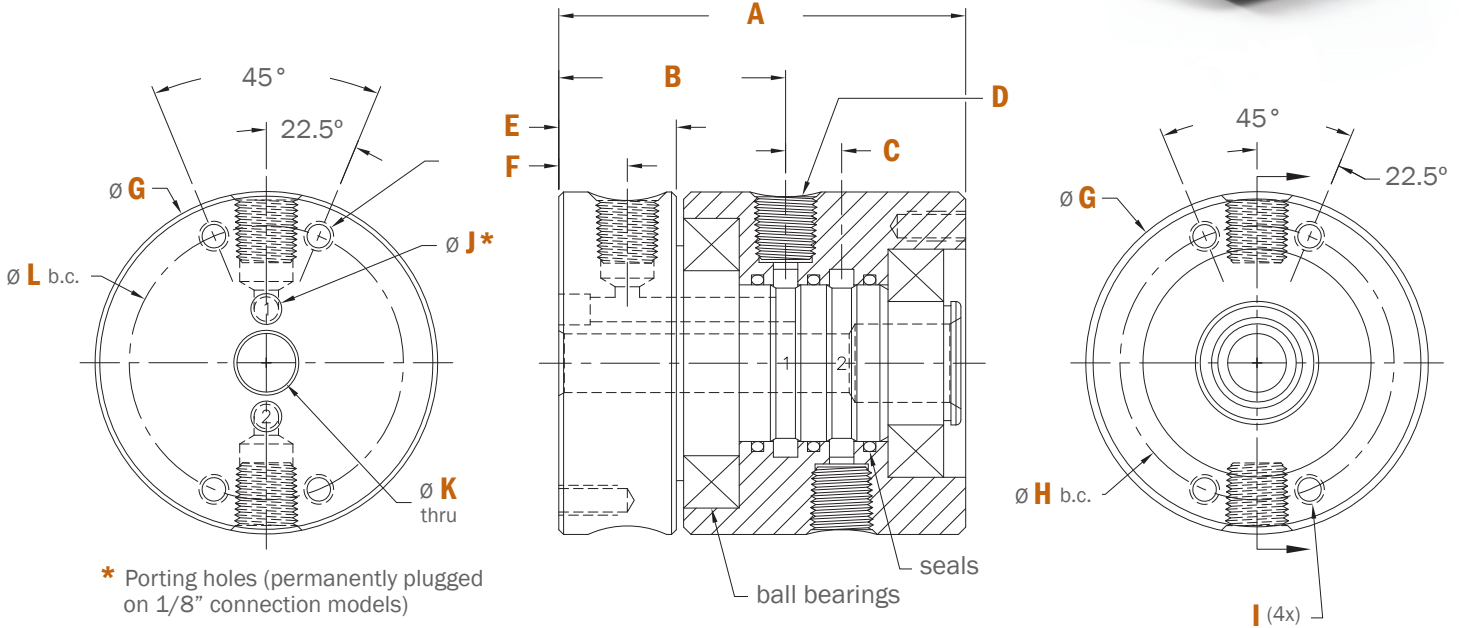
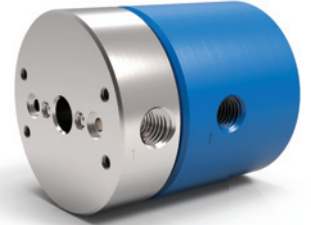

PART #	A	B	C	D	E	F	G	H	I
LT-2121	2.60"	1.45"	.358"	1/8"- 27 NPT	.750"	.438"	2.187"	1.750"	#10-24
LT-2321	4.62"	2.48"	.830"	3/8"- 18 NPT	1.250"	.750"	3.437"	3.000"	1/4"-20
LTM-2121	66.0mm	36.8mm	9.09mm	R _c 1/8"- 28 BSPT	19.05mm	11.11mm	55.55mm	44.45mm	M5x0.8
LTM-2321	117.4mm	63.1mm	21.08mm	R _c 3/8"- 19 BSPT	31.75mm	19.05mm	87.30mm	76.20mm	M6x1.0

PART #	J	K	L
LT-2121	.16"	.375"	1.750"
LT-2321	.38"	.375"	3.000"
LTM-2121	4.0mm	9.53mm	44.45mm
LTM-2321	9.5mm	9.53mm	76.20mm

Reference tolerances listed on the PDF Part Drawing.

OPTIONAL O-RING FACE SEAL GLAND CONNECTION



Must specify when ordering. Please add "-OF" to the Part Number. (Example: LT-2121-OF)

LT-2121-OF [LTM-2121-OF]

Ø .14 [3.6mm] to intersect C-bore: Ø .281" [7.14mm]
Gland: .0500" [1.270mm] dp.
O-ring: 2-007

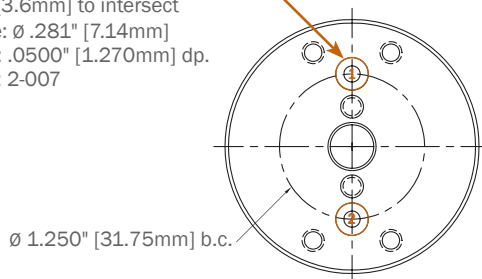

LT-2321-OF [LTM-2321-OF]

Ø .38 [9.5mm] to depth
Ø .500" [12.70mm] ID x
Ø .656" [16.66mm] OD
Gland: .0500" [1.270mm] dp.
O-ring: 2-014

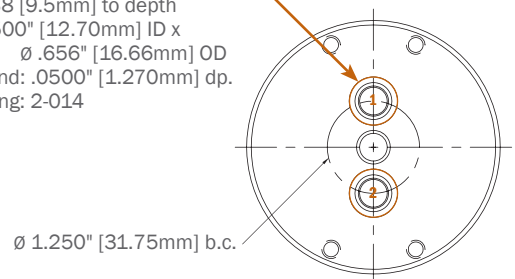

2 Flow Passage: Optional Equipment

OPTIONAL ELECTRICAL SLIP RING COVERS

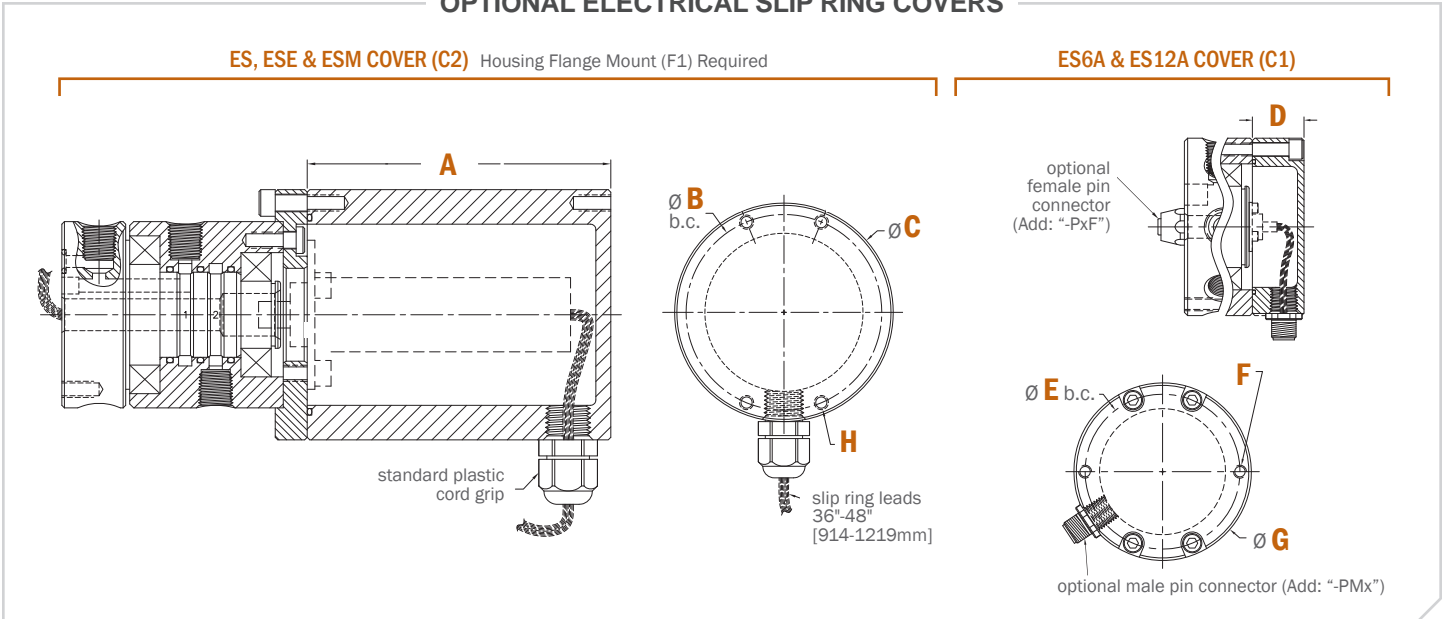

OPTIONAL SHAFT & HOUSING FLANGE MOUNTS

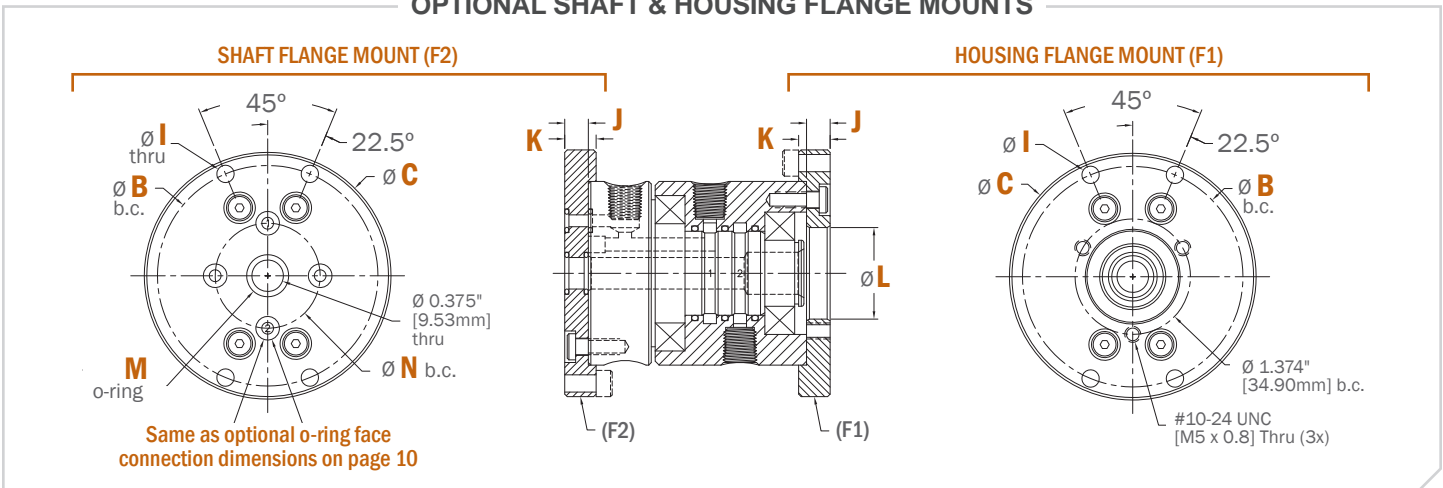

PART #	A	B	C	D	E	F	G	H	I (thru)	J
LT-2121	3.56"	2.630"	2.937"	.875"	1.750"	#10-24	2.187"	#10-24	.206"	.28"
LT-2321	3.56"	4.000"	4.437"	1.000"	3.000"	1/4"-20	3.437"	1/4"-20	.265"	.41"
LTM-2121	90.5mm	66.80mm	74.60mm	22.23mm	44.45mm	M5x0.8	55.55mm	M5x0.8	5.50mm	7.1mm
LTM-2321	90.5mm	101.60mm	112.70mm	25.40mm	76.20mm	M6x1.0	87.30mm	M6x1.0	6.60mm	10.3mm

PART #	K	L	M	N
LT-2121	.375"	1.090"	2-012	1.250"
LT-2321	.500"	1.100"	2-012	1.250"
LTM-2121	9.53mm	27.69mm	2-012	31.75mm
LTM-2321	12.70mm	27.94mm	2-012	31.75mm

Reference tolerances listed on the PDF Part Drawing.

4 Flow Passage: Dimensions

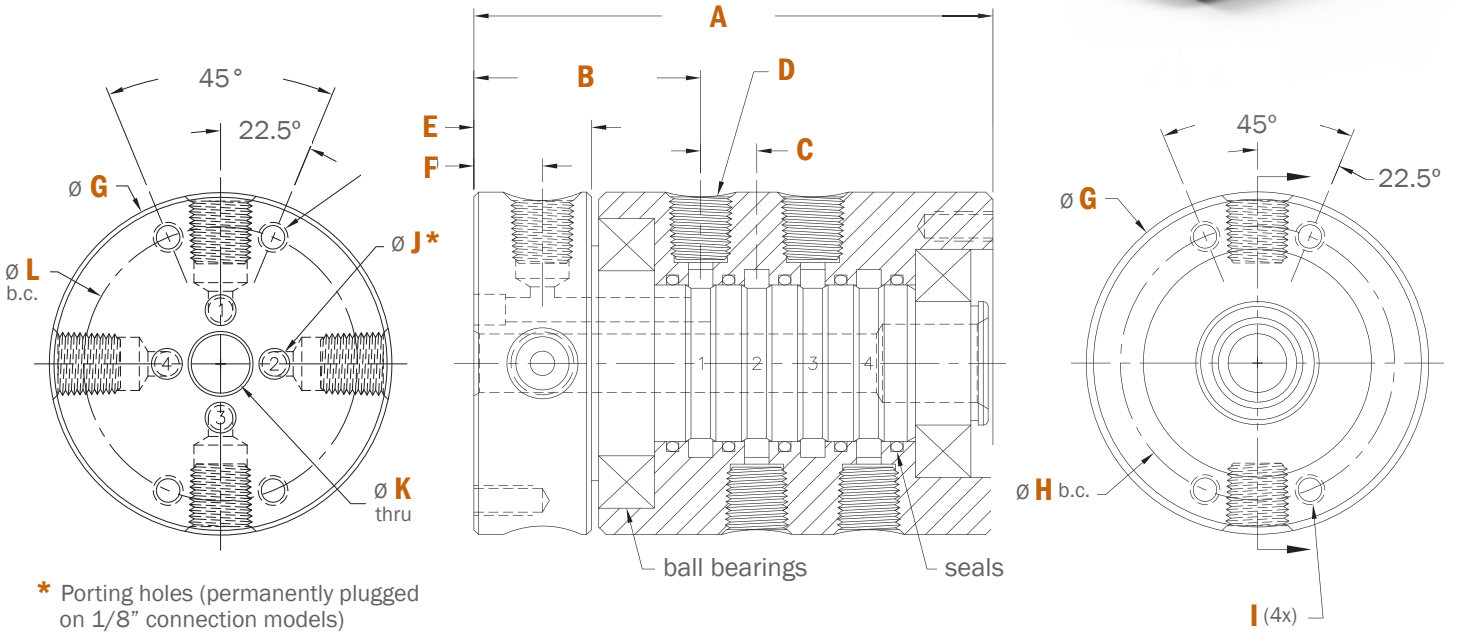
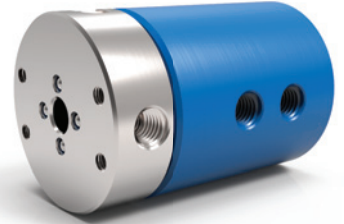

PART #	A	B	C	D	E	F
LT-2141	3.31"	1.45"	.358"	1/8"- 27 NPT	.750"	.438"
LT-2341	6.28"	2.48"	.830"	3/8"- 18 NPT	1.250"	.750"
LTM-2141	84.2mm	36.8mm	9.09mm	R _c 1/8"-28 BSPT	19.05mm	11.11mm
LTM-2341	159.6mm	63.1mm	21.08mm	R _c 3/8"-19 BSPT	31.75mm	19.05mm

PART #	G	H	I	J	K (thru)	L
LT-2141	2.187"	1.750"	#10-24	.16"	.375"	1.750"
LT-2341	3.437"	3.000"	1/4"-20	.38"	.375"	3.000"
LTM-2141	55.55mm	44.45mm	M5x0.8	4.0mm	9.53mm	44.45mm
LTM-2341	87.30mm	76.20mm	M6x1.0	9.5mm	9.53mm	76.20mm

Reference tolerances listed on the PDF Part Drawing.

OPTIONAL O-RING FACE SEAL GLAND CONNECTION



Must specify when ordering. Please add "-OF" to the Part Number. (Example: LT-2141-OF)

LT-2141-OF [LTM-2141-OF]

Ø .14 [3.6mm] to intersect C-bore: Ø .281" [7.14mm]
Gland: .0500" [1.270mm] dp.
O-ring: 2-007

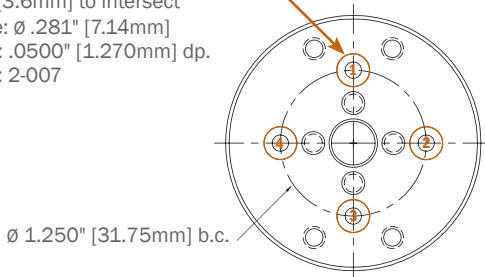

LT-2341-OF [LTM-2341-OF]

Ø .38 [9.5mm] to depth
Ø .500" [12.70mm] ID x
Ø .656" [16.66mm] OD
Gland: .0500" [1.270mm] dp.
O-ring: 2-014

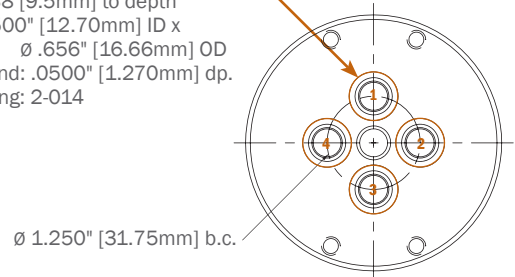

4 Flow Passage: Optional Equipment

OPTIONAL ELECTRICAL SLIP RING COVERS

ES, ESE & ESM COVER (C2) Housing Flange Mount (F1) Required

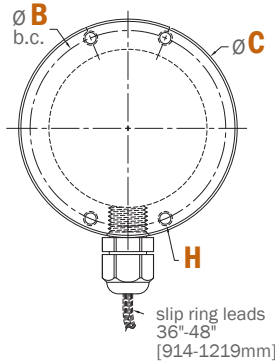
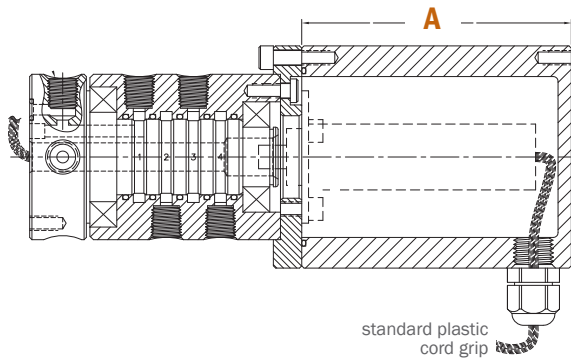

ES6A & ES12A COVER (C1)

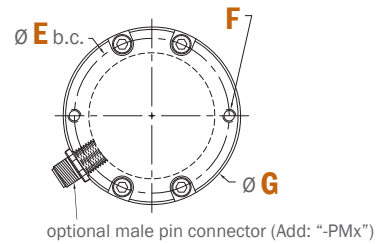
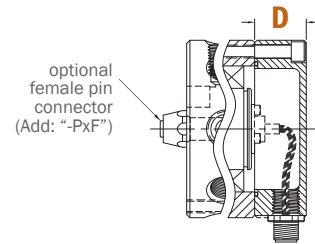

OPTIONAL SHAFT & HOUSING FLANGE MOUNTS

SHAFT FLANGE MOUNT (F2)

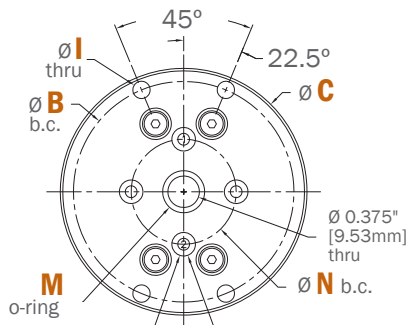

Same as optional o-ring face connection dimensions on page 12

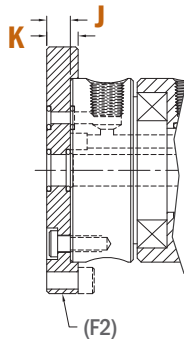

HOUSING FLANGE MOUNT (F1)

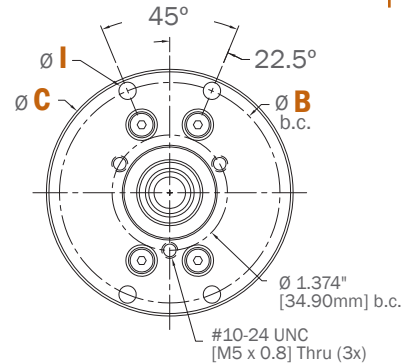
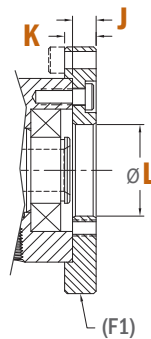

PART #	A	B	C	D	E	F	G	H	I (thru)	J
LT-2141	3.56"	2.630"	2.937"	.875"	1.750"	#10-24	2.187"	#10-24	.206"	.28"
LT-2341	3.56"	4.000"	4.437"	1.000"	3.000"	1/4"-20	3.437"	1/4"-20	.265"	.41"
LTM-2141	90.5mm	66.80mm	74.60mm	22.23mm	44.45mm	M5x0.8	55.55mm	M5x0.8	5.50mm	7.1mm
LTM-2341	90.5mm	101.60mm	112.70mm	25.40mm	76.20mm	M6x1.0	87.30mm	M6x1.0	6.60mm	10.3mm

PART #	K	L	M	N
LT-2141	.375"	1.090"	2-012	1.250"
LT-2341	.500"	1.100"	2-012	1.250"
LTM-2141	9.53mm	27.69mm	2-012	31.75mm
LTM-2341	12.70mm	27.94mm	2-012	31.75mm

Reference tolerances listed on the PDF Part Drawing.

8 Flow Passage: Dimensions

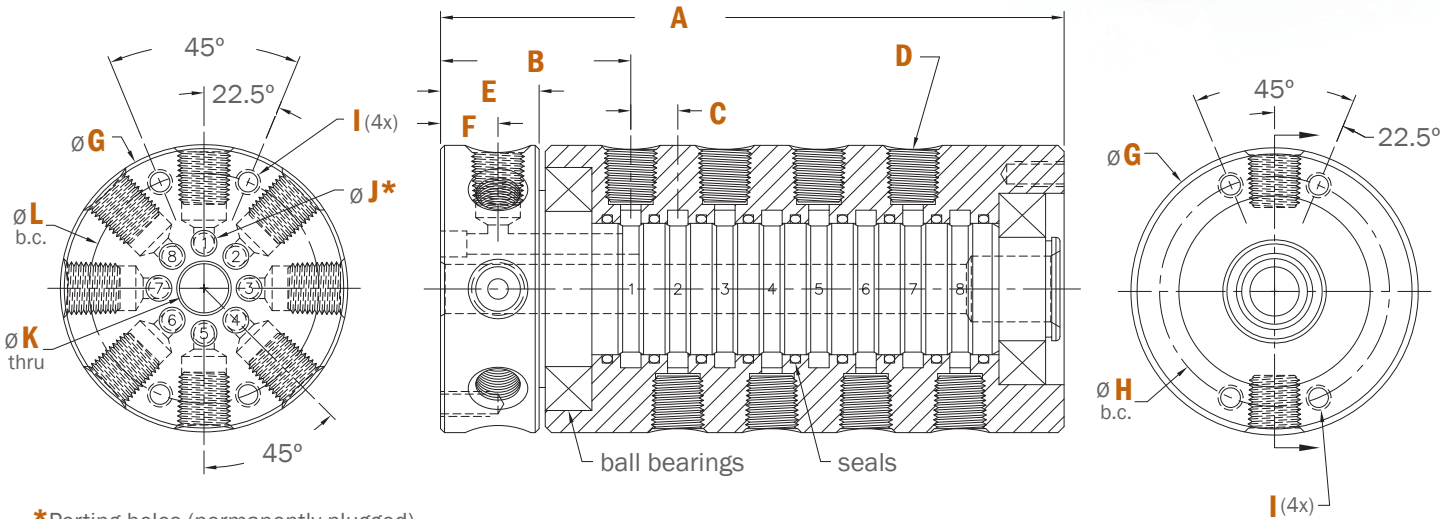

*Porting holes (permanently plugged)

PART #	A	B	C	D	E	F
LT-2181	4.75"	1.45"	.358"	1/8"-27 NPT	.750"	.438"
LT-2381	9.61"	2.48"	.830"	3/8"-18 NPT	1.250"	.750"
LTM-2181	120.5mm	36.8mm	9.09mm	R _c 1/8"-28 BSPT	19.05mm	11.11mm
LTM-2381	244.0mm	63.1mm	21.08mm	R _c 3/8"-19 BSPT	31.75mm	19.05mm

PART #	G	H	I	J	K (thru)	L
LT-2181	2.187"	1.750"	#10-24	.16"	.375"	1.750"
LT-2381	3.437"	3.000"	1/4"-20	.38"	.44"	3.000"
LTM-2181	55.55mm	44.45mm	M5x0.8	4.0mm	9.53mm	44.45mm
LTM-2381	87.30mm	76.20mm	M6x1.0	9.5mm	11.1mm	76.20mm

Reference tolerances listed on the PDF Part Drawing.

OPTIONAL O-RING FACE SEAL GLAND CONNECTION



Must specify when ordering. Please add "-OF" to the Part Number. (Example: LT-2181-OF)

LT-2181-OF [LTM-2181-OF]

Ø .14 [3.6mm] to intersect
C-bore: Ø .281" [7.14mm]
Gland: .0500" [1.270mm] dp.
O-ring: 2-007

Ø 1.250" [31.75mm] b.c.

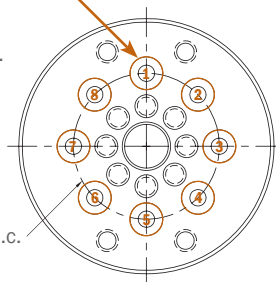

LT-2381-OF [LTM-2381-OF]

Ø .34 [8.7mm] to intersect
Ø .438" [11.13mm] ID x
Ø .594" [15.09mm] OD
Gland: .0500" [1.270mm] dp.
O-ring: 2-013

Ø 2.375" [60.33mm] b.c.

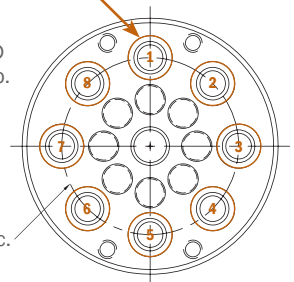

8 Flow Passage: Optional Equipment

OPTIONAL ELECTRICAL SLIP RING COVERS

ES, ESE & ESM COVER (C2) Housing Flange Mount (F1) Required

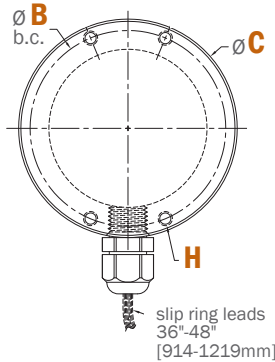
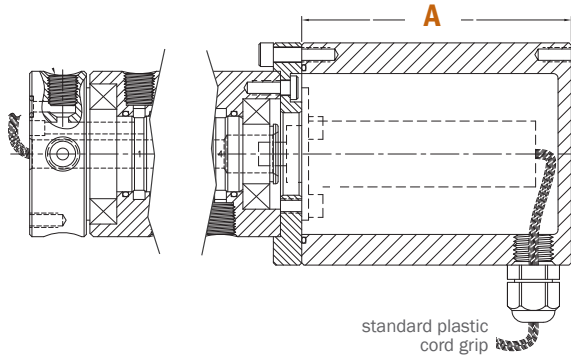

ES6A & ES12A COVER (C1)

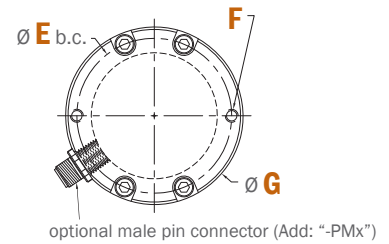
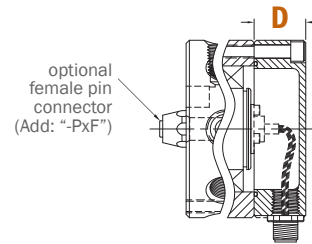

OPTIONAL SHAFT & HOUSING FLANGE MOUNTS

SHAFT FLANGE MOUNT (F2)

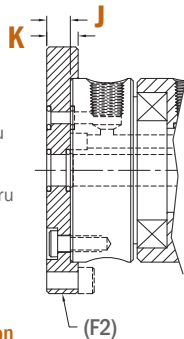
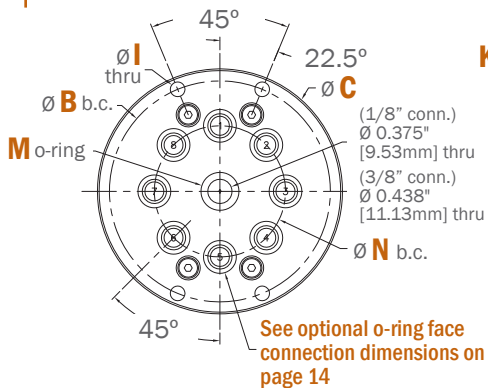

HOUSING FLANGE MOUNT (F1)

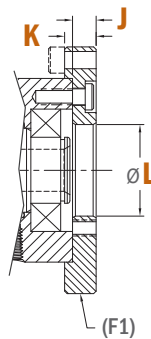
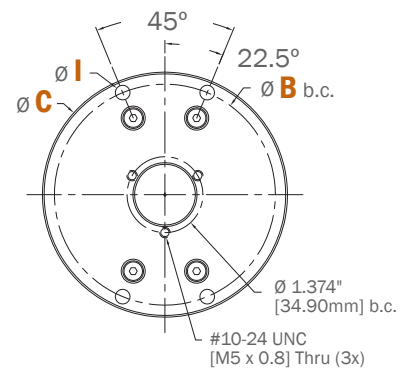

PART #	A	B	C	D	E	F	G	H	I	J
LT-2181	3.56"	2.630"	2.937"	.875"	1.750"	#10-24	2.187"	#10-24	.206"	.28"
LT-2381	3.56"	4.000"	4.437"	1.000"	3.000"	1/4"-20	3.437"	1/4"-20	.265"	.41"
LTM-2181	90.5mm	66.80mm	74.60mm	22.23mm	44.45mm	M5x0.8	55.55mm	M5x0.8	5.50mm	7.1mm
LTM-2381	90.5mm	101.60mm	112.70mm	25.40mm	76.20mm	M6x1.0	87.30mm	M6x1.0	6.60mm	10.3mm

PART #	K	L	M	N
LT-2181	.375"	1.090"	2-012	1.250"
LT-2381	.500"	1.100"	2-015	2.375"
LTM-2181	9.53mm	27.69mm	2-012	31.75mm
LTM-2381	12.70mm	27.94mm	2-015	60.33mm

Reference tolerances listed on the PDF Part Drawing.

12 Flow Passage: Dimensions

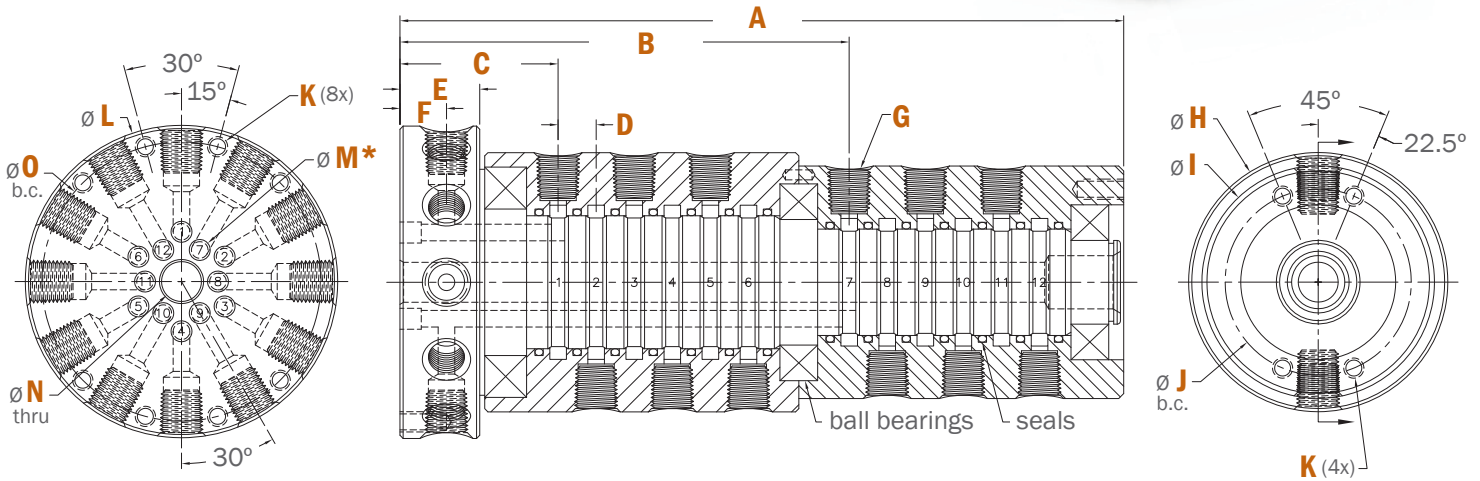
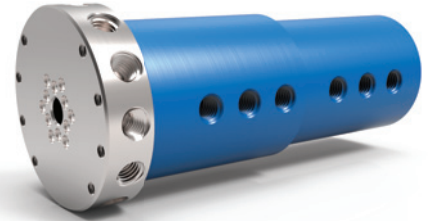

* Porting holes (permanently plugged)

PART #	A	B	C	D	E	F
LT-21121	6.81"	4.22"	1.49"	.358"	.750"	0.438"
LT-23121	14.07"	8.53"	2.68"	.830"	1.250"	0.750"
LTM-21121	172.9mm	107.3mm	37.8mm	9.09mm	19.05mm	11.11mm
LTM-23121	357.4mm	216.6mm	68.1mm	21.08mm	31.75mm	19.05mm

Reference tolerances listed on the PDF Part Drawing.

PART #	G	H	I	J	K	L	M	N	O
LT-21121	1/8"-27 NPT	2.437"	2.187"	1.750"	#10-24	2.937"	.16"	.375"	2.625"
LT-23121	3/8"-18 NPT	4.438"	3.437"	3.000"	1/4"-20	4.438"	.38"	.44"	4.000"
LTM-21121	R _c 1/8"-28 BSPT	61.90mm	55.55mm	44.45mm	M5x0.8	74.60mm	4.0mm	9.53mm	66.68mm
LTM-23121	R _c 3/8"-19 BSPT	112.73mm	87.30mm	76.20mm	M6x1.0	112.73mm	9.5mm	11.1mm	101.60mm

OPTIONAL O-RING FACE SEAL GLAND CONNECTION



Must specify when ordering. Please add "-OF" to the Part Number. (Example: LT-21121-OF)

LT-21121-OF [LTM-21121-OF]

Ø .14 [3.6mm] to intersect
C-bore: Ø .281" [7.14mm]
Gland: .0500" [1.270mm] dp.
O-ring: 2-007

Ø 1.500" [38.10mm] b.c.

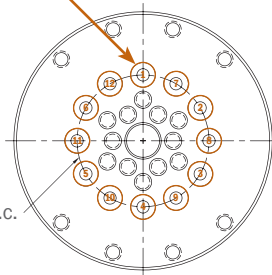

LT-23121-OF [LTM-23121-OF]

Ø .34 [8.7mm] to intersect
Ø .438" [11.13mm] ID x
Ø .594" [15.09mm] OD
Gland: .0500" [1.270mm] dp.
O-ring: 2-013

Ø 3.000" [76.20mm] b.c.

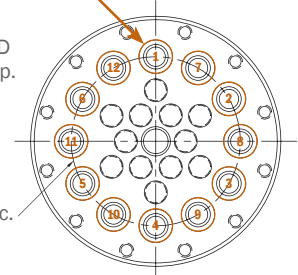

12 Flow Passage: Optional Equipment

OPTIONAL ELECTRICAL SLIP RING COVERS

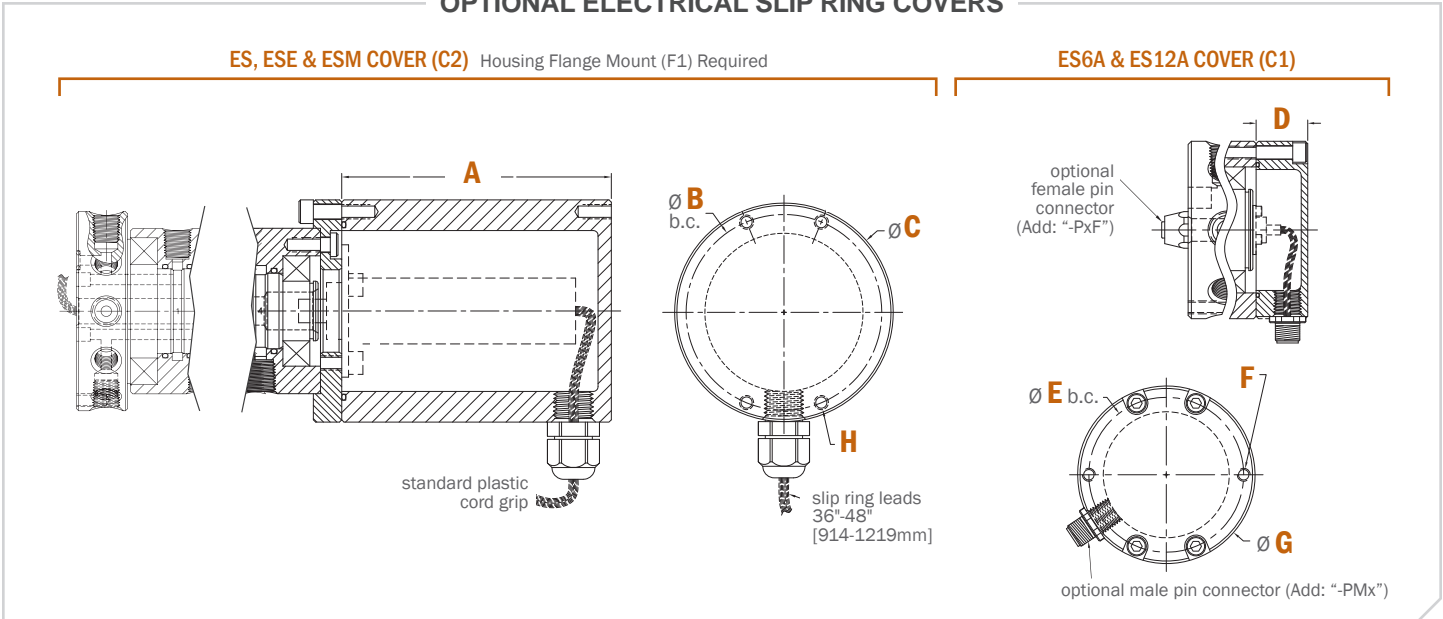

OPTIONAL SHAFT & HOUSING FLANGE MOUNTS

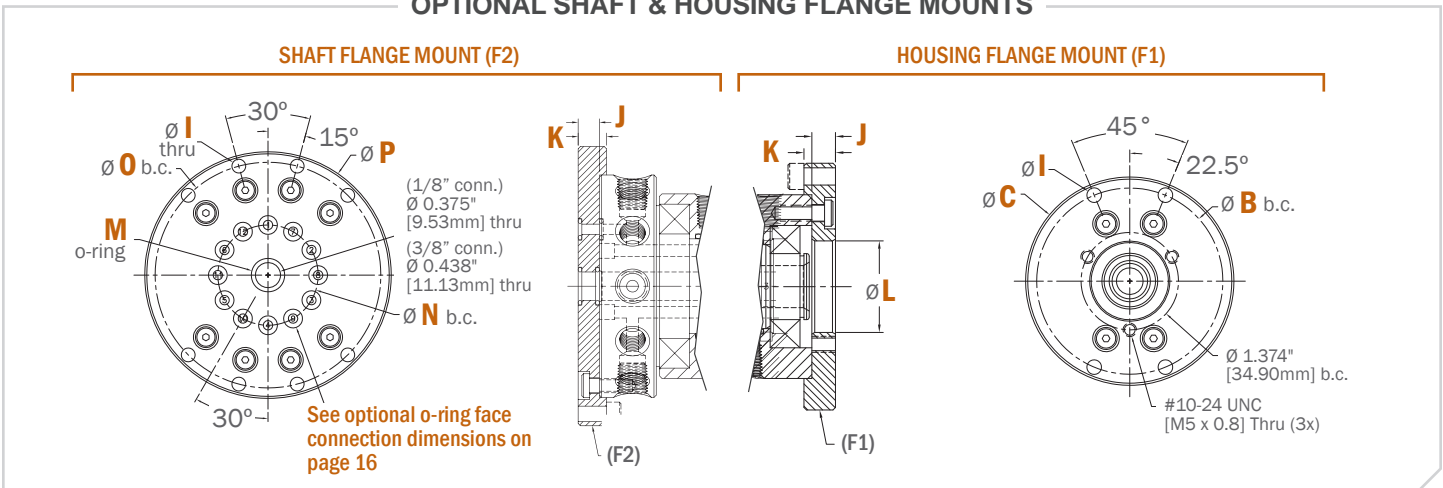

PART #	A	B	C	D	E	F	G	H	I	J
LT-21121	3.56"	2.630"	2.937"	.875"	1.750"	#10-24	2.187"	#10-24	.206"	.28"
LT-23121	3.56"	4.000"	4.437"	1.000"	3.000"	1/4"-20	3.437"	1/4"-20	.265"	.41"
LTM-21121	90.5mm	66.80mm	74.60mm	22.23mm	44.45mm	M5x0.8	55.55mm	M5x0.8	5.50mm	7.1mm
LTM-23121	90.5mm	101.60mm	112.70mm	25.40mm	76.20mm	M6x1.0	87.30mm	M6x1.0	6.60mm	10.3mm

PART #	K	L	M	N	O	P
LT-21121	.375"	1.090"	2-012	1.500"	3.375"	3.687"
LT-23121	.500"	1.100"	2-015	3.000"	5.000"	5.438"
LTM-21121	9.53mm	27.69mm	2-012	38.10mm	85.73mm	93.65mm
LTM-23121	12.70mm	27.94mm	2-015	76.20mm	127.00mm	138.13mm

Reference tolerances listed on the PDF Part Drawing.

24 Flow Passage: Dimensions

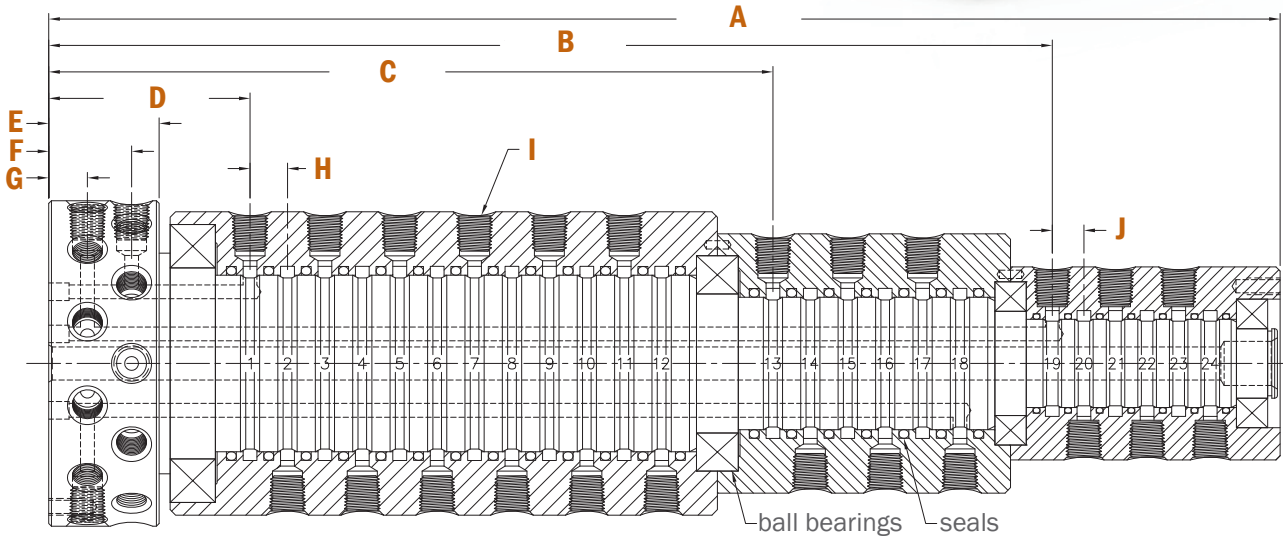

PART #	LT-21241	LTM-21241
A	13.95"	354.4mm
B	11.37"	288.8mm
C	8.21"	208.4mm
D	2.28"	57.9mm
E	1.250"	31.75mm
F	.938"	23.83mm
G	.438"	11.13mm
H	.424"	10.77mm
I	1/8"-27 NPT	R _c 1/8"-28 BSPT
J	.358"	9.09mm
K	2.938"	74.63mm
L	2.187"	55.55mm
M	3.438"	87.33mm
N	1.750"	44.45mm
O	#10-24	M5x0.8
P	3.688"	93.68mm
Q	3.250"	82.55mm
R	.375"	9.53mm
S	.16"	4.0mm

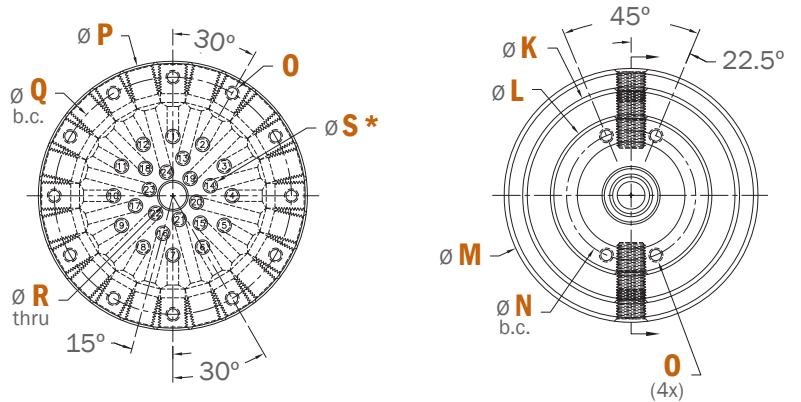

* Porting size (Permanently plugged)

OPTIONAL O-RING FACE SEAL GLAND CONNECTION



Must specify when ordering. Please add "-OF" to the Part Number. (Example: LT-21241-OF)

LT-21241-OF [LTM-21241-OF]
 Ø .14 [3.6mm] to intersect
 C-bore: Ø .281" [7.14mm]
 Gland: .0500" [1.270mm] dp.
 O-ring: 2-007

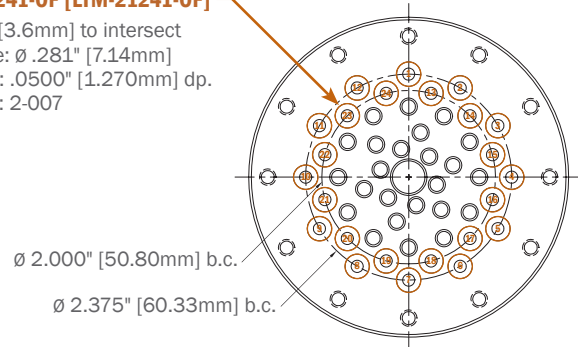

Reference tolerances listed on the PDF Part Drawing.

24 Flow Passage: Optional Equipment

OPTIONAL ELECTRICAL SLIP RING COVERS

ES, ESE & ESM COVER (C2) Housing Flange Mount (F1) Required

ES6A & ES12A COVER (C1)

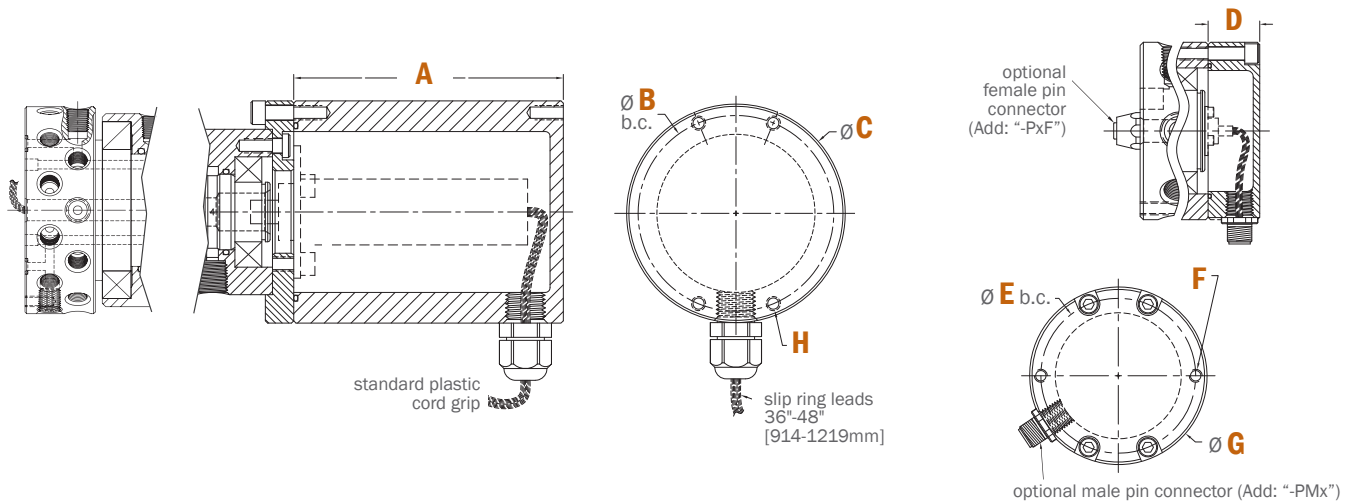

OPTIONAL SHAFT & HOUSING FLANGE MOUNTS

SHAFT FLANGE MOUNT (F2)

HOUSING FLANGE MOUNT (F1)

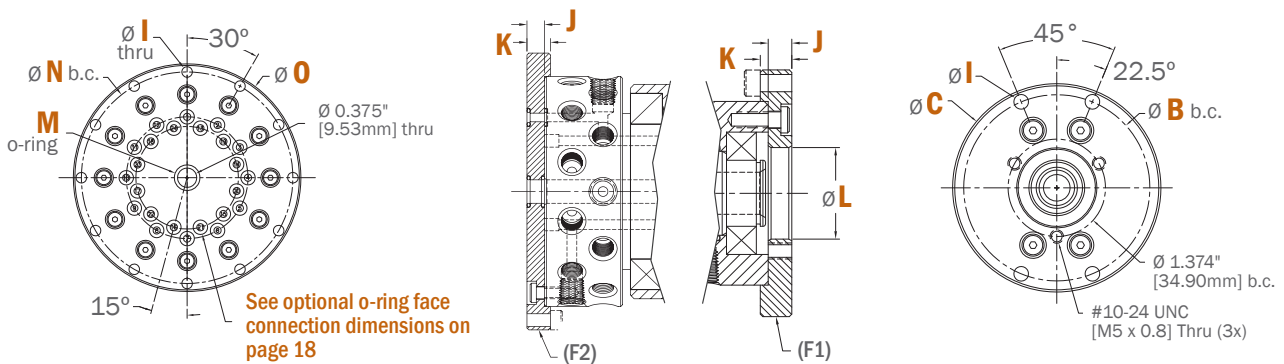

PART #	A	B	C	D	E	F	G	H
LT-21241	3.56"	2.630"	2.937"	.875"	1.750"	#10-24	2.187"	#10-24
LTM-21241	90.5mm	66.80mm	74.60mm	22.23mm	44.42mm	M5x0.8	55.55mm	M5x0.8

PART #	I	J	K	L	M	N	O
LT-21241	.206"	.28"	.375"	1.090"	2-012	4.125"	4.438"
LTM-21241	5.50mm	7.1mm	9.53mm	27.69mm	2-012	104.78mm	112.73mm

Reference tolerances listed on the PDF Part Drawing.

Customer Interface using O-Ring Seal Connection

CUSTOMER INTERFACE EXAMPLE

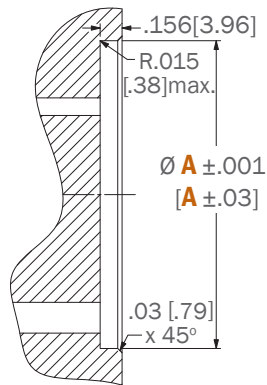

LT SERIES ROTARY UNION

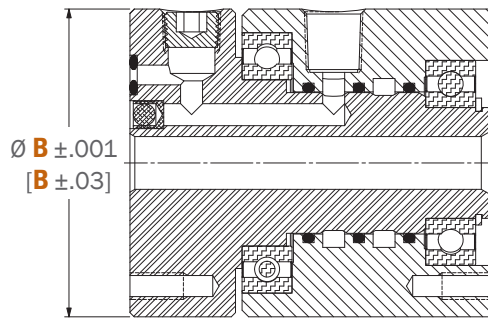
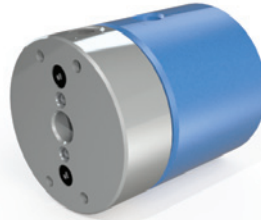

PART #	A	B	C (Nx)
LT(M)-2121	2.190" [55.63mm]	2.187" [55.55mm]	.281" [7.14mm] (2x)
LT(M)-2141	2.190" [55.63mm]	2.187" [55.55mm]	.281" [7.14mm] (4x)
LT(M)-2181	2.190" [55.63mm]	2.187" [55.55mm]	.281" [7.14mm] (8x)
LT(M)-2321	3.440" [87.38mm]	3.437" [87.30mm]	.656" [16.66mm] (2x)
LT(M)-2341	3.440" [87.38mm]	3.437" [87.30mm]	.656" [16.66mm] (4x)
LT(M)-2381	3.440" [87.38mm]	3.437" [87.30mm]	.594" [15.09mm] (8x)
LT(M)-21121	2.940" [74.68mm]	2.937" [74.60mm]	.281" [7.14mm] (12x)
LT(M)-21241	3.691" [93.75mm]	3.688" [93.68mm]	.281" [7.14mm] (24x)
LT(M)-23121	4.441" [112.8mm]	4.438" [112.73mm]	.594" [15.09mm] (12x)

Electrical Slip Ring Integration Options

- + Ethernet Slip Rings Available
- + 100 BaseT & 1000 BaseT Ethernet Connections
- + High-Quality, Gold-on-Gold Contacts
- + Capsule & Thru-bore Options
- + Low Electrical Noise
- + Analog/Digital Transfer
- + Cord Sets & Pin Connectors Options
- + Compatible With a Range of Data Bus Protocols

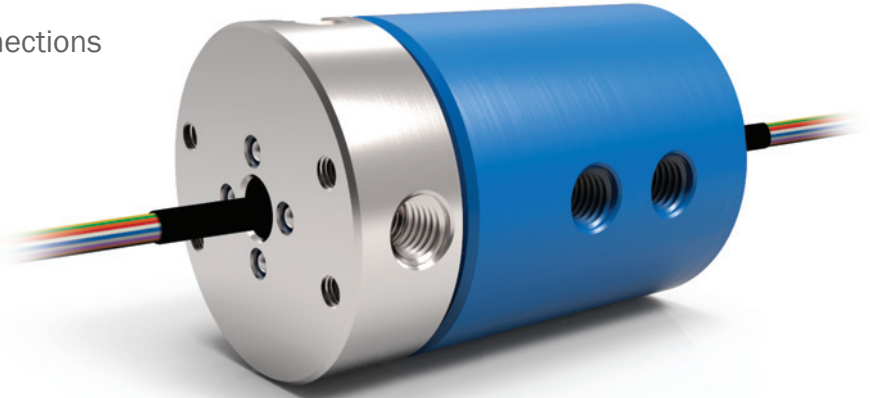

AVAILABLE SLIP RINGS¹

PART #	# OF CIRCUITS	MAX AMPS/ CIRCUIT	MAX VOLTS	MAX DATA SPEED
ES6A ⁴	6	2	120	Under 50 Mbps
ES6 ⁴	6	2	240	Under 50 Mbps
ES12A ⁴	12	2	120	Under 50 Mbps
ES12 ⁴	12	2	240	Under 50 Mbps
ES18 ⁴	18	2	240	Under 50 Mbps
ES24 ⁴	24	2	240	Under 50 Mbps
ES36 ⁴	36	2	240	Under 50 Mbps
ES56 ⁴	56	2	240	Under 50 Mbps
ESE64 ²	10	(6x) 2A	240	100 Mbps
ESE264 ²	12	(2x) 5A, (6x) 2A	240	100 Mbps
ESE224 ²	8	(2x) 10A, (2x) 2A	240	100 Mbps
ESE2124 ²	18	(2x) 5A, (12x) 2A	240	100 Mbps
ESE284 ²	14	(2x) 10A, (8x) 2A	240	100 Mbps
ESE438 ³	51	(43x) 2A	240	1 Gbps
ESE4358 ³	47	(4x) 5A, (35x) 2A	240	1 Gbps
ESE2358 ³	45	(2x) 10A, (35x) 2A	240	1 Gbps
ESE8278 ³	43	(8x) 5A, (27x) 2A	240	1 Gbps
ESE24278 ³	41	(2x) 10A, (4x) 5A, (27x) 2A	240	1 Gbps

PART #	# OF CIRCUITS	MAX AMPS/ CIRCUIT	MAX VOLTS	MAX DATA SPEED
ESM36 ⁴	9	(3x) 10A, (6x) 2A	240	Under 50 Mbps
ESM312 ⁴	15	(3x) 5A, (12x) 2A	240	Under 50 Mbps
ESM420 ⁴	24	(4x) 10A, (20x) 2A	240	Under 50 Mbps
ESM428 ⁴	32	(4x) 5A, (28x) 2A	240	Under 50 Mbps
ESM440 ⁴	44	(4x) 10A, (40x) 2A	240	Under 50 Mbps
ESM448 ⁴	52	(4x) 5A, (48x) 2A	240	Under 50 Mbps

¹ All slip ring lead wire lengths are 48" (1219mm)

² 100 BaseT Ethernet connections

³ 1000 BaseT Ethernet connections

⁴ In order to successfully transfer digital data signals, a variety of conditions must be met. Please consult with DSTI for approval.

Installation & Mounting

PREPARATION:

Remove the rotary union from the shipping container. Inspect the entire assembly, including all passage connections to make sure that they are clean and no visual damage occurred during transport. If the assembly is a rotary union/electrical slip ring, the electrical slip ring may be packaged separately to protect during shipping. If this is the case, mount the electrical slip ring to the rotating union assembly using the supplied hardware.

RECOMMENDED INSTALLATION PRACTICE:

DSTI does not recommend mounting the rotary union with both the shaft & housing components solidly bolted into place. One of the two components should be mounted in a manner that allows for some movement in the event of misalignment or run-out during rotation. Using only the supply lines or hoses to fix the stationary component in place is also not recommended. An anti-rotation arm that attaches to the stationary part of the rotary union assembly and rests against part of the equipment framework is recommended (see figure 1).

MOUNTING A ROTARY UNION W/ AN ELECTRICAL SLIP RING:

Make sure the electrical wiring is fixed in place and protected from contact with other components or equipment. Care should be taken to make sure the slip ring area remains clean and dry during use.

SHAFT MOUNTING, O-RING FACE SEAL CONNECTIONS

Make sure the rotary union shaft face & equipment mounting surface is clean and free from dents or chips to insure proper installation. Equipment pilot bore needs to be concentric to the center line of the rotary union shaft to assure proper function. Install face mount O-rings into groove or counter bore in rotating union shaft face. General assembly grease can be used as needed to hold O-rings into place during assembly. Align rotary union shaft with equipment pilot bore and flow passages, then insert into place. Bolt assembly into place using tapped holes on the face of the rotating union shaft or purchase an optional shaft flange (F2) for help mounting the union.

THESE INSTRUCTIONS ARE INTENDED TO BE USED AS A GENERAL GUIDE, PLEASE CONSULT DSTI TO DISCUSS ANY SPECIFIC QUESTIONS RELATED TO YOUR INSTALLATION.

SHAFT MOUNTING, THREADED PORT CONNECTIONS

When mounting the shaft using threaded port connections, make sure all fittings are properly tightened & pipe thread sealant is used as required. Equipment mounting surface needs to be concentric to the center line of the rotary union shaft to assure proper function. After all fittings are in place, bolt assembly into place using tapped holes on the face of the rotating union shaft or purchase an optional shaft flange (F2) for help mounting the union.

HOUSING MOUNTING

If using the housing to secure the union into a piece of equipment, bolt the assembly into place using the tapped holes on the back of the housing or purchase an optional housing flange (F1) for help mounting the union.

INITIAL START-UP:

After rotary union is installed, a dry run is recommended to assure proper mounting of the rotating union assembly. Begin rotation of the equipment, and verify that while rotating at the maximum operating speed there is no visible movement of the rotary union assembly due to misalignment.



- ① LT HOUSING
- ② LT SHAFT
- ③ ANTI-ROTATE DEVICE EXAMPLE
- ④ O-RINGS FOR OPTIONAL FACE SEAL MOUNTING
- ⑤ OPTIONAL FLANGE FOR MOUNTING AND/OR FACE CONNECTION

Warranty

DSTI Warrants, for a period of 2 years from the date of original delivery, its products to be free from defects in material and workmanship. DSTI's obligation under this warranty is limited to repair or replacement at its factory of any part or parts of said products which shall be returned to DSTI with transportation charges prepaid and which DSTI's examination shall disclose to its satisfaction to have been defective. Under no circumstances shall DSTI be held liable for loss, damage, cost of repair of consequential damages of any kind in connection with the sale, use or repair of any product purchased from DSTI. Warranty is subject to change.



TDS Precision Products GmbH
Industriestrasse 1a
CH-8157 Dielsdorf

T + 41 44 885 30 80
info@tds-pp.com
www.tds-pp.com