

ATOM SC Series

SVTN A 03

Coreless BLDC motors

2 Pole Brushless DC Motors with Integrated Electronics

ATOM SC Series

SVTN A 03

Coreless BLDC motors

2 Pole Brushless DC Motors with Integrated Electronics



Cost effective



Easy to use



Long service life



The benefits of this build technology join the simplicity of use of a brushed DC motor with the longevity of a brushless motor, maintaining cost-effectiveness and ease of integration.

The lack of cogging is typical of the coreless motors and guarantees a reduce ripple torque, a linear correlation between torque, speed and low inertia.

The miniaturization of the electronics allows to maintain the diameter of the motor unvaried with a slight increase in length.

Benefits

Long lifetime

High efficiency

Low noise

High reliability

No cogging

Low inertia

Cost-effective

Product code

SVTN A 03 ○○◇◇ - □□ - 〡 - 〡☆☆

A Series

03 Brushless DC Motors

○ Diameter

◇ Length

□ Voltage

〡 Shaft
Single shaft [S]; Double shaft [D]

〡 Direction of rotation
CW [0]; CCW [1]; Third wire for direction control [2]

☆☆ Customizations

Features

Winding	3 phase (2-wires DC regulated)
Operating temperature	-30° +100° C
Connectors	Flying leads or JST* or MOLEX*
Magnets	Neodymium
Construction technology	Coreless winding system
Estimated operating lifetime	Lifetime depends on motor working conditions. It can reach 20.000 work hours under optimal conditions (almost 100 hours under extreme conditions).

Customizations

Flange	Shape
Shaft	Length/Diameter/D-Cut
Leadwire	PVC/Silicon/Teflon/UL No/Dimension/length
Connector	JST/MOLEX

*Optional



ATOM SC Series SVTN A 03 1228

1.5 Watt

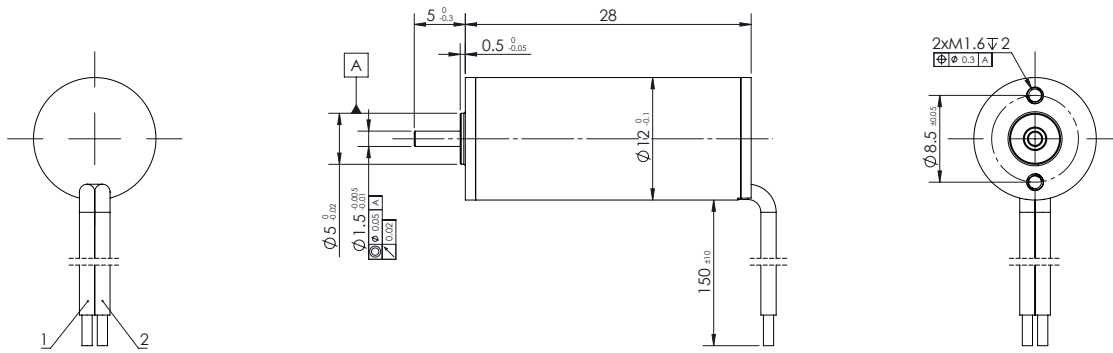

V 2.6.5

Values	Unit	SVTN A 03 1228-06..
Motor Data		
1	Nominal voltage	V
2	No load speed	rpm
3	No load current	mA
4	Nominal speed	rpm
5	Nominal torque	mNm
6	Nominal current	A
7	Stall torque	mNm
8	Stall current	A
9	Max. efficiency	%
Characteristics		
10	Supply Voltage +Vcc	V
11	Direction of rotation	CCW viewed from shaft endend
12	Torque constant	mNm/A
13	Speed constant	rpm/V
14	Speed/torque gradient	rpm/mNm
15	Mechanical time constant	ms
16	Rotor inertia	gcm ²
Mechanical data		
17	Thermal resistance housing-ambient	38.3 K/W
18	Thermal resistance winding-housing	9.6 K/W
19	Thermal time constant winding	5 s
20	Thermal time constant motor	196 s
21	Ambient temperature	-30...+100°C
22	Max. permissible winding temperature	+125°C
23	Max. permissible speed	50000 rpm
24	Radial play	preloaded
25	Max. axial load (dynamic)	0,3
26	Max.force for press fits (static)	11N
27	(static, shaft supported)	200 N
28	Max. radial loading, 5mm from flange	4.3 N
Other specifications		
29	Number of poles	2
30	Number of phases	3
31	Weight	12.2 g

Connection

Connection	PTFE
Pin 1	+VCC AWG24 red
Pin 2	GND AWG24 black

Optional:

Pin 3	FR* AWG28 yellow
-------	------------------

*Reverse direction when connected to GND

Gearbox combinations

SVTG A 10
SVTG A 12

Caution
Incorrect lead connection will damage the controller!



ATOM SC Series
SVTN A 03 1638

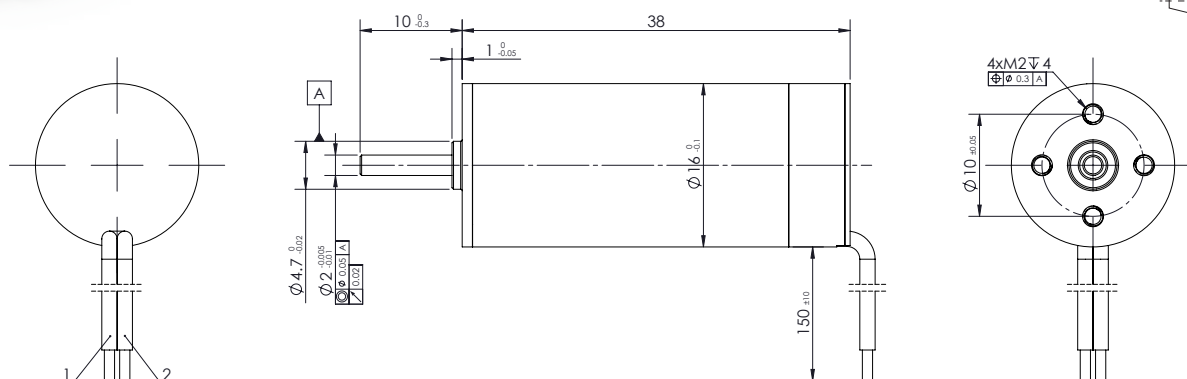

V 2.6.5

Values	Unit	SVTN A 03 1638-06..	1638-12..	
Motor Data				
1	Nominal voltage	V	6	12
2	No load speed	rpm	8832	17664
3	No load current	mA	110	100
4	Nominal speed	rpm	6102	14491
5	Nominal torque	mNm	1,5	2
6	Nominal current	A	0,37	0,43
7	Stall torque	mNm	4,85	11,1
8	Stall current	A	0,96	1,91
9	Max. efficiency	%	43,7	59,5
Characteristics				
10	Supply Voltage +Vcc	V	4.5..7	8..13
11	Direction of rotation		CCW viewed from shaft end	
12	Torque constant	mNm/A	5,74	6,11
13	Speed constant	rpm/V	1664	1562
14	Speed/torque gradient	rpm/mNm	1820	1604
15	Mechanical time constant	ms	8,2	7,2
16	Rotor inertia	gcm ²	0,4	0,4
Mechanical data				
17	Thermal resistance housing-ambient		20,2 K/W	
18	Thermal resistance winding-housing		8,7 K/W	
19	Thermal time constant winding		7 s	
20	Thermal time constant motor		238 s	
21	Ambient temperature		-30...+100°C	
22	Max. permissible winding temperature		+150°C	
23	Max. permissible speed		35000 rpm	
24	Radial play		preloaded	
25	Max. axial load (dynamic)		1.3 N	
26	Max. force for press fits (static)		15 N	
27	(static, shaft supported)		350 N	
28	Max. radial loading, 5mm from flange		5 N	
Other specifications				
29	Number of poles		2	
30	Number of phases		3	
31	Weight		27 g	

Connection

Connection		PTFE
Pin 1	+VCC	AWG24 red
Pin 2	GND	AWG24 black
Optional:		
Pin 3	FR*	AWG28 yellow

*Reverse direction when connected to GND

Gearbox combinations

SVTG A 10

Caution
Incorrect lead connection will damage the controller!

INTEGRATED
ELECTRONICS



ATOM SC Series
SVTN A 03 2238

9 Watt

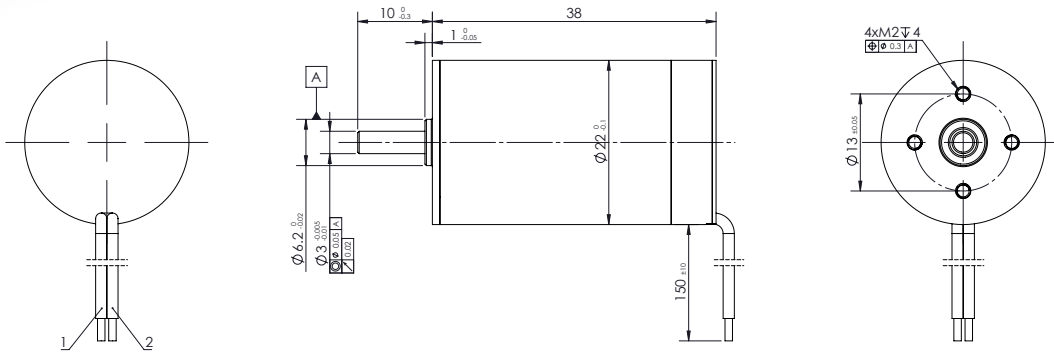

V 2.6.5

Values	Unit	SVTN A 03 2238-12..	2238-18..	2238-24..	
Motor Data					
1	Nominal voltage	V	12	18	24
2	No load speed	rpm	17445	17830	17721
3	No load current	mA	220	150	110
4	Nominal speed	rpm	14292	14700	14260
5	Nominal torque	mNm	6	6	6
6	Nominal current	A	1,13	0,75	0,57
7	Stall torque	mNm	44,8	45,3	40,7
8	Stall current	A	7,44	4,96	3,39
9	Max. efficiency	%	70,2	70,3	67,7
Characteristics					
10	Supply Voltage +Vcc	V	10..28	10..28	10..28
11	Direction of rotation		CCW viewed from shaft end		
12	Torque constant	mNm/A	6,15	9,32	12,3
13	Speed constant	rpm/V	1553	1024	777
14	Speed/torque gradient	rpm/mNm	407	399	447
15	Mechanical time constant	ms	6,4	6,2	7
16	Rotor inertia	gcm ²	1,5	1,5	1,5
Mechanical data					
17	Thermal resistance housing-ambient		15.2 K/W		
18	Thermal resistance winding-housing		6.0 K/W		
19	Thermal time constant winding		11 s		
20	Thermal time constant motor		383 s		
21	Ambient temperature		-30...+100°C		
22	Max. permissible winding temperature		+150°C		
23	Max. permissible speed		35000 rpm		
24	Radial play		preloaded		
25	Max. axial load (dynamic)		3,5 N		
26	Max. force for press fits (static)		44 N		
27	Max. radial loading, 5mm from flange		15 N		
Other specifications					
28	Number of poles		2		
29	Number of phases		3		
30	Weight		63 g		

Connection

Connection		PTFE
Pin 1	+VCC	AWG24 red
Pin 2	GND	AWG24 black

Optional:

Pin 3	FR*	AWG28 yellow
-------	-----	--------------

*Reverse direction when connected to GND

Gearbox combinations

SVTG B 22*
SVTG B 24*

Caution
Incorrect lead connection will damage the controller!

*On request. Contact factory.



ATOM SC Series
SVTN A 03 2246

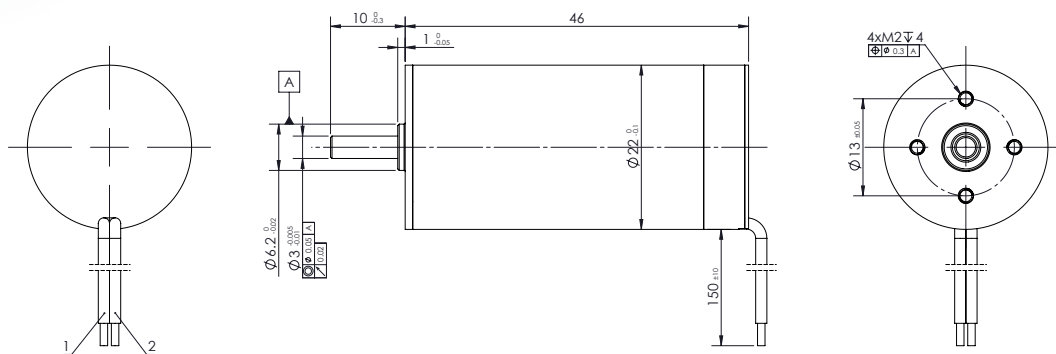

V 2.6.5

Values	Unit	SVTN A 03 2246-12..	2246-24..	
Motor Data				
1	Nominal voltage	V	12	24
2	No load speed	rpm	11570	15627
3	No load current	mA	170	140
4	Nominal speed	rpm	10085	12771
5	Nominal torque	mNm	8	12
6	Nominal current	A	1,01	1,01
7	Stall torque	mNm	60,4	82,8
8	Stall current	A	6,7	6,28
9	Max. efficiency	%	70,5	71,8
Characteristics				
10	Supply Voltage +Vcc	V	10..28	10..28
11	Direction of rotation		CCW viewed from shaft end	
12	Torque constant	mNm/A	9,2	13,4
13	Speed constant	rpm/V	1038	712
14	Speed/torque gradient	rpm/mNm	202	203
15	Mechanical time constant	ms	4,8	4,8
16	Rotor inertia	gcm ²	2,3	2,3
Mechanical data				
17	Thermal resistance housing-ambient	K/W	12,7	
18	Thermal resistance winding-housing	K/W	5,0	
19	Thermal time constant winding	s	12	
20	Thermal time constant motor	s	420	
21	Ambient temperature	°C	-30...+100°C	
22	Max. permissible winding temperature	°C	+150°C	
23	Max. permissible speed	rpm	35000 rpm	
24	Radial play		preloaded	
25	Max. axial load (dynamic)	N	3,5 N	
26	Max. force for press fits (static)	N	44 N	
27	Max. radial loading, 5mm from flange	N	15 N	
Other specifications				
28	Number of poles		2	
29	Number of phases		3	
30	Weight	g	79 g	

Connection

Connection			PTFE
Pin 1	+VCC		AWG24 red
Pin 2	GND		AWG24 black
Optional:			
Pin 3	FR*		AWG28 yellow

*Reverse direction when connected to GND

Gearbox combinations

SVTG B 22*
SVTG B 24*

Caution
Incorrect lead connection will damage the controller!

*On request. Contact factory.



ATOM SC Series SVTN A 03 2452

8 Watt

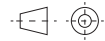
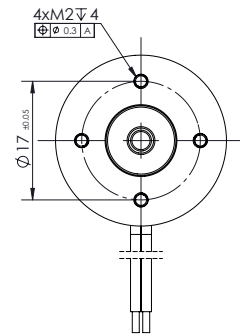
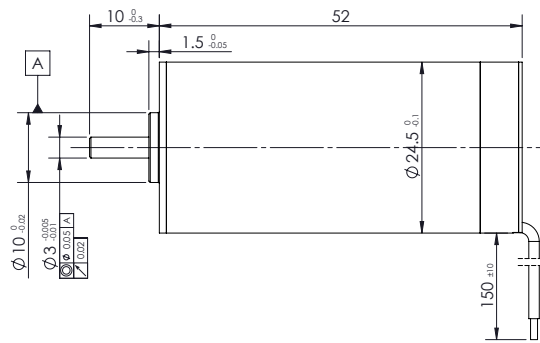
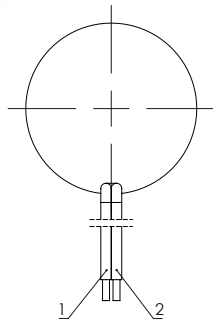

V 2.6.5

Values	Unit	SVTN A 03 2452-12..	2452-24..	
Motor Data				
1	Nominal voltage	V	12	24
2	No load speed	rpm	6904	6980
3	No load current	mA	103	70
4	Nominal speed	rpm	5087	5089
5	Nominal torque	mNm	14	14
6	Nominal current	A	0,98	0,51
7	Stall torque	mNm	87	85,2
8	Stall current	A	5,58	2,73
9	Max. efficiency	%	71,7	67,9
Characteristics				
10	Supply Voltage +Vcc	V	10..28	10..28
11	Direction of rotation		CCW viewed from shaft end	
12	Torque constant	mNm/A	15,9	32
13	Speed constant	rpm/V	601	298
14	Speed/torque gradient	rpm/mNm	81,3	81,9
15	Mechanical time constant	ms	3,6	3,6
16	Rotor inertia	gcm ²	4,2	4,2
Mechanical data				
17	Thermal resistance housing-ambient	K/W	11,6	
18	Thermal resistance winding-housing	K/W	5,6	
19	Thermal time constant winding	s	30	
20	Thermal time constant motor	s	557	
21	Ambient temperature	°C	-30...+100°C	
22	Max. permissible winding temperature	°C	+150°C	
23	Max. permissible speed	rpm	30000 rpm	
24	Radial play		preloaded	
25	Max. axial load (dynamic)	N	3,5 N	
26	Max. force for press fits (static)	N	44 N	
27	Max. radial loading, 5mm from flange	N	15 N	
Other specifications				
28	Number of poles		2	
29	Number of phases		3	
30	Weight	g	112 g	

Connection

Connection		PTFE
Pin 1	+VCC	AWG24 red
Pin 2	GND	AWG24 black

Optional:

Pin 3	FR*	AWG28 yellow
-------	-----	--------------

*Reverse direction when connected to GND

Gearbox combinations

SVTG B 24*
SVTG B 28*

Caution
Incorrect lead connection will damage the controller!

*On request. Contact factory.



ATOM SC Series
SVTN A 03 2459

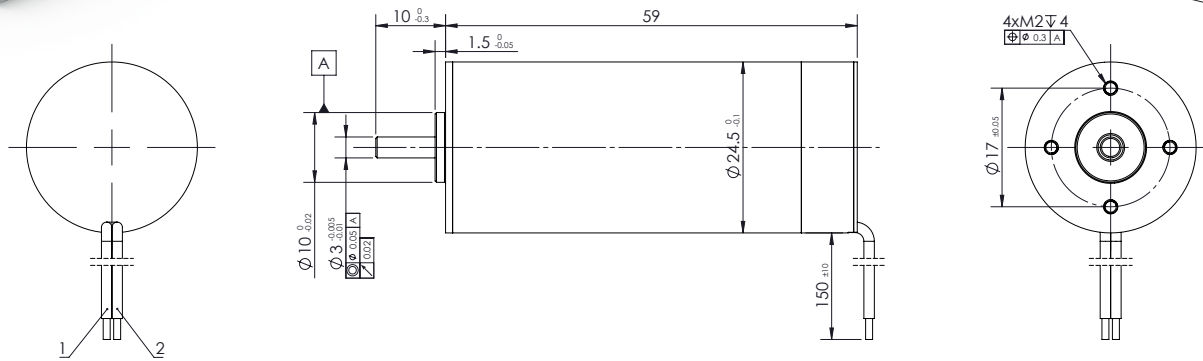

V 2.6.5

Values	Unit	SVTN A 03 2459-12..	2459-24..	
Motor Data				
1	Nominal voltage	V	12	24
2	No load speed	rpm	7699	7655
3	No load current	mA	114	73
4	Nominal speed	rpm	6958	6597
5	Nominal torque	mNm	14	20
6	Nominal current	A	1,07	0,75
7	Stall torque	mNm	145	145
8	Stall current	A	10	4,98
9	Max. efficiency	%	79,8	77,2
Characteristics				
10	Supply Voltage +Vcc	V	10..28	10..28
11	Direction of rotation		CCW viewed from shaft end	
12	Torque constant	mNm/A	14,7	29,5
13	Speed constant	rpm/V	649	324
14	Speed/torque gradient	rpm/mNm	52,9	52,9
15	Mechanical time constant	ms	3,3	3,3
16	Rotor inertia	gcm ²	5,9	5,9
Mechanical data				
17	Thermal resistance housing-ambient		10.2 K/W	
18	Thermal resistance winding-housing		6.4 K/W	
19	Thermal time constant winding		36 s	
20	Thermal time constant motor		555 s	
21	Ambient temperature		-30...+100°C	
22	Max. permissible winding temperature		+150°C	
23	Max. permissible speed		30000 rpm	
24	Radial play		preloaded	
25	Max. axial load (dynamic)		3.5 N	
26	Max. force for press fits (static)		44 N	
27	Max. radial loading, 5mm from flange		15 N	
Other specifications				
28	Number of poles		2	
29	Number of phases		3	
30	Weight		130 g	

Connection

Connection		PTFE
Pin 1	+VCC	AWG24 red
Pin 2	GND	AWG24 black
Optional:		
Pin 3	FR*	AWG28 yellow

*Reverse direction when connected to GND

Gearbox combinations

- SVTG B 24
- SVTG B 28

Caution
Incorrect lead connection will damage the controller!



ATOM SC Series
SVTN A 03 2854

10 Watt

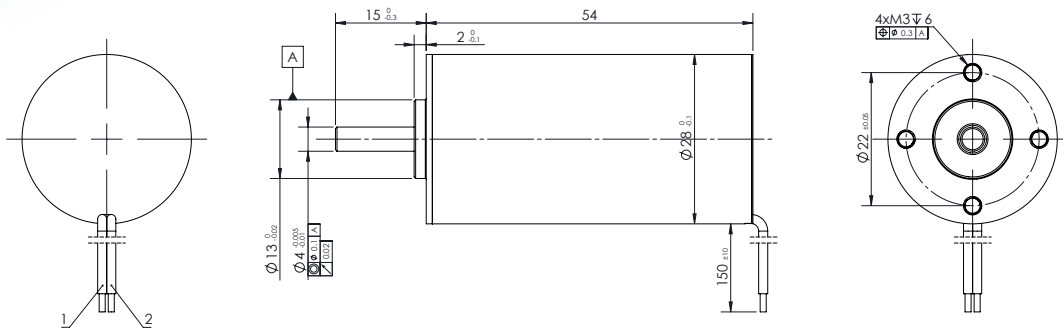
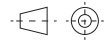

V 2.6.5

Values	Unit	SVTN A 03 2854-12..	2854-24..	
Motor Data				
1	Nominal voltage	V	12	24
2	No load speed	rpm	6878	6700
3	No load current	mA	121	76
4	Nominal speed	rpm	5674	5157
5	Nominal torque	mNm	15	18
6	Nominal current	A	1,04	0,62
7	Stall torque	mNm	85,7	78,1
8	Stall current	A	5,38	2,43
9	Max. efficiency	%	72,3	67,8
Characteristics				
10	Supply Voltage +Vcc	V	10..28	10..28
11	Direction of rotation		CCW viewed from shaft end	
12	Torque constant	mNm/A	16,3	33,1
13	Speed constant	rpm/V	586	288
14	Speed/torque gradient	rpm/mNm	80,3	85,7
15	Mechanical time constant	ms	4,4	4,7
16	Rotor inertia	gcm ²	5,2	5,2
Mechanical data				
17	Thermal resistance housing-ambient		9.6 K/W	
18	Thermal resistance winding-housing		6.3 K/W	
19	Thermal time constant winding		37 s	
20	Thermal time constant motor		584 s	
21	Ambient temperature		-30...+100°C	
22	Max. permissible winding temperature		+150°C	
23	Max. permissible speed		25000 rpm	
24	Radial play		preloaded	
25	Max. axial load (dynamic)		7.5 N	
26	Max. force for press fits (static)		100 N	
27	Max. radial loading, 5mm from flange		25 N	
Other specifications				
28	Number of poles		2	
29	Number of phases		3	
30	Weight		153 g	

Connection

Connection		PTFE
Pin 1	+VCC	AWG20 red
Pin 2	GND	AWG20 black

Optional:

Pin 3	FR*	AWG28 yellow
-------	-----	--------------

*Reverse direction when connected to GND

Gearbox combination

SVTG B 28

Caution
Incorrect lead connection will damage the controller!

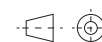

ATOM SC Series
SVTN A 03 2863

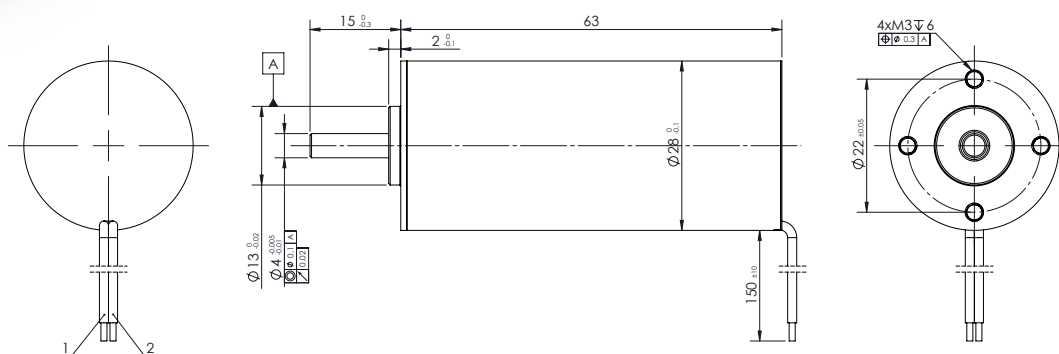

V 2.6.5

Values	Unit	SVTN A 03 2863-12..	2863-24..	
Motor Data				
1	Nominal voltage	V	12	24
2	No load speed	rpm	4168	4162
3	No load current	mA	70	60
4	Nominal speed	rpm	3264	3033
5	Nominal torque	mNm	25	25
6	Nominal current	A	0,99	0,53
7	Stall torque	mNm	115	92,1
8	Stall current	A	4,33	1,79
9	Max. efficiency	%	76,2	66,7
Characteristics				
10	Supply Voltage +Vcc	V	10..28	10..28
11	Direction of rotation		CCW viewed from shaft end	
12	Torque constant	mNm/A	27	53,2
13	Speed constant	rpm/V	353	179
14	Speed/torque gradient	rpm/mNm	36,2	45,2
15	Mechanical time constant	ms	3,2	4,0
16	Rotor inertia	gcm ²	8,5	8,5
Mechanical data				
17	Thermal resistance housing-ambient		7,1 K/W	
18	Thermal resistance winding-housing		5 K/W	
19	Thermal time constant winding		51 s	
20	Thermal time constant motor		552 s	
21	Ambient temperature		-30...+100°C	
22	Max. permissible winding temperature		+150°C	
23	Max. permissible speed		25000 rpm	
24	Radial play		preloaded	
25	Max. axial load (dynamic)		7,5 N	
26	Max. force for press fits (static)		100 N	
27	Max. radial loading, 5mm from flange		25 N	
Other specifications				
28	Number of poles		2	
29	Number of phases		3	
30	Weight		188 g	

Connection

Connection		PTFE
Pin 1	+VCC	AWG20 red
Pin 2	GND	AWG20 black
Optional:		
Pin 3	FR*	AWG28 yellow

*Reverse direction when connected to GND

Gearbox combinations

SVTG B 28

Caution
Incorrect lead connection will damage the controller!



ATOM SC Series
SVTN A 03 3270

26 Watt

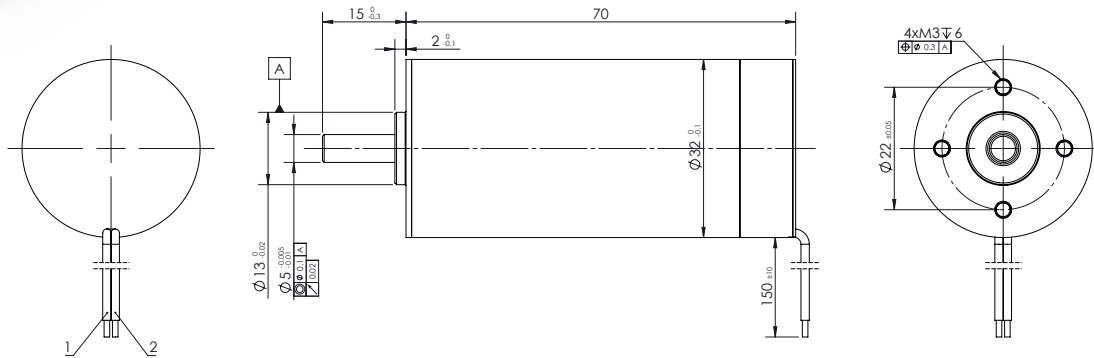

V 2.6.5

Values	Unit	SVTN A 03 3270-12..	3270-24..	
Motor Data				
1	Nominal voltage	V	12	24
2	No load speed	rpm	7200	7100
3	No load current	mA	194	110
4	Nominal speed	rpm	6623	6243
5	Nominal torque	mNm	25	40
6	Nominal current	A	1,78	1,36
7	Stall torque	mNm	312	331
8	Stall current	A	20	10,5
9	Max. efficiency	%	81,3	80,6
Characteristics				
10	Supply Voltage +Vcc	V	10..28	10..28
11	Direction of rotation		CCW viewed from shaft end	
12	Torque constant	mNm/A	15,8	31,9
13	Speed constant	rpm/V	606	299
14	Speed/torque gradient	rpm/mNm	23,1	21,4
15	Mechanical time constant	ms	3,7	3,5
16	Rotor inertia	gcm ²	15,5	15,5
Mechanical data				
17	Thermal resistance housing-ambient	K/W	5	
18	Thermal resistance winding-housing	K/W	4	
19	Thermal time constant winding	s	52	
20	Thermal time constant motor	s	540	
21	Ambient temperature	°C	-30...+100	
22	Max. permissible winding temperature	°C	+150	
23	Max. permissible speed	rpm	25000	
24	Radial play		preloaded	
25	Max. axial load (dynamic)	N	7,5	
26	Max. force for press fits (static)	N	100	
27	Max. radial loading, 5mm from flange	N	25	
Other specifications				
28	Number of poles		2	
29	Number of phases		3	
30	Weight	g	255	

Connection

Connection		PTFE
Pin 1	+VCC	AWG20 red
Pin 2	GND	AWG20 black

Optional:

Pin 3	FR*	AWG28 yellow
-------	-----	--------------

*Reverse direction when connected to GND

Gearbox combinations

- SVTG B 32
- SVTG B 36

Caution
Incorrect lead connection will damage the controller!



ATOM SC Series
SVTN A 03 3673

17 Watt

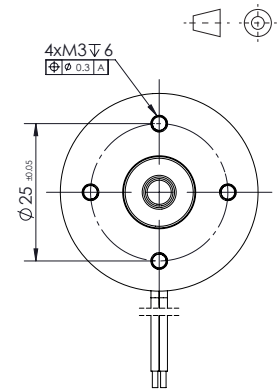
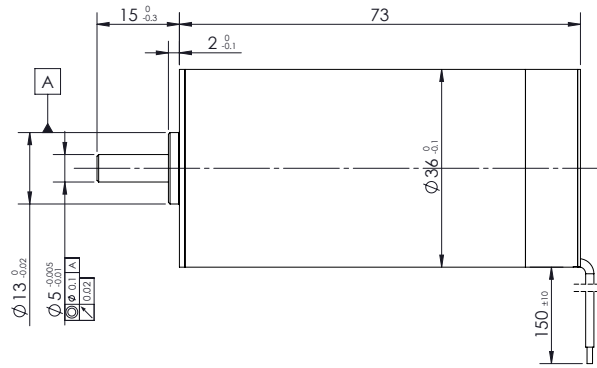
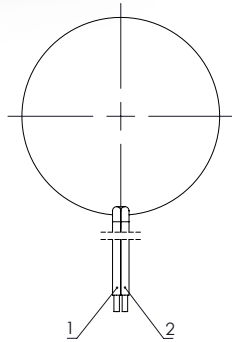

V 2.6.5

Values	Unit	SVTN A 03 3673-12..	3673-24..	
Motor Data				
1	Nominal voltage	V	12	24
2	No load speed	rpm	4070	4042
3	No load current	mA	148	84
4	Nominal speed	rpm	3229	3223
5	Nominal torque	mNm	50	50
6	Nominal current	A	1,95	0,98
7	Stall torque	mNm	242	247
8	Stall current	A	8,89	4,52
9	Max. efficiency	%	75,9	74,6
Characteristics				
10	Supply Voltage +Vcc	V	10..28	10..28
11	Direction of rotation		CCW viewed from shaft end	
12	Torque constant	mNm/A	27,7	55,7
13	Speed constant	rpm/V	345	172
14	Speed/torque gradient	rpm/mNm	16,8	16,4
15	Mechanical time constant	ms	3,4	3,3
16	Rotor inertia	gcm ²	19,5	19,5
Mechanical data				
17	Thermal resistance housing-ambient		4.9 K/W	
18	Thermal resistance winding-housing		1.6 K/W	
19	Thermal time constant winding		45 s	
20	Thermal time constant motor		630 s	
21	Ambient temperature		-30...+100°C	
22	Max. permissible winding temperature		+150°C	
23	Max. permissible speed		20000 rpm	
24	Radial play		preloaded	
25	Max. axial load (dynamic)		7.5 N	
26	Max. force for press fits (static)		100 N	
27	Max. radial loading, 5mm from flange		25 N	
Other specifications				
28	Number of poles		2	
29	Number of phases		3	
30	Weight		317 g	

Connection

Connection		PTFE
Pin 1	+VCC	AWG20 red
Pin 2	GND	AWG20 black
Optional:		
Pin 3	FR*	AWG28 yellow

*Reverse direction when connected to GND

Gearbox combinations

- SVTG B 36
- SVTG B 42

Caution
Incorrect lead connection will damage the controller!



ATOM SC Series
SVTN A 03 3683

24 Watt

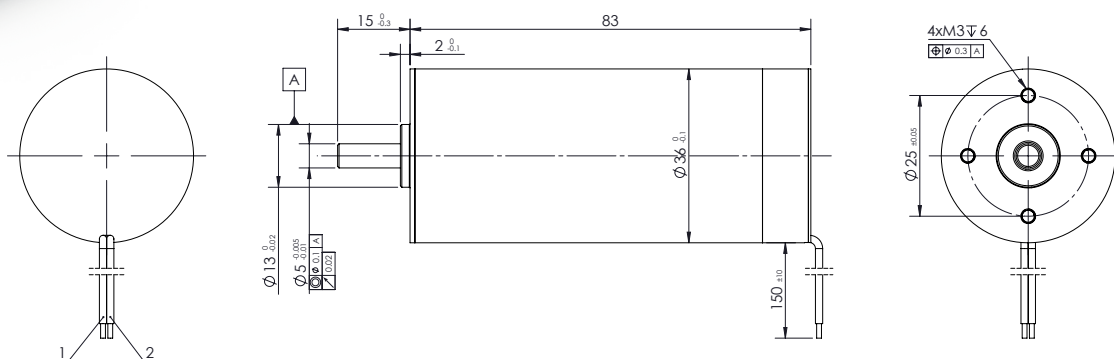
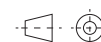

V 2.6.5

Values	Unit	SVTN A 03 3683-12..	3683-24..	
Motor Data				
1	Nominal voltage	V	12	24
2	No load speed	rpm	3278	3273
3	No load current	mA	137	78
4	Nominal speed	rpm	2294	2304
5	Nominal torque	mNm	100	100
6	Nominal current	A	3,04	1,53
7	Stall torque	mNm	333	338
8	Stall current	A	9,8	4,98
9	Max. efficiency	%	77,8	76,5
Characteristics				
10	Supply Voltage +Vcc	V	10..28	10..28
11	Direction of rotation		CCW viewed from shaft end	
12	Torque constant	mNm/A	34,5	68,9
13	Speed constant	rpm/V	277	139
14	Speed/torque gradient	rpm/mNm	9,83	9,69
15	Mechanical time constant	ms	2,2	2,2
16	Rotor inertia	gcm ²	21,5	21,5
Mechanical data				
17	Thermal resistance housing-ambient	K/W	5	
18	Thermal resistance winding-housing	K/W	2.3	
19	Thermal time constant winding	s	46	
20	Thermal time constant motor	s	816	
21	Ambient temperature	°C	-30...+100	
22	Max. permissible winding temperature	°C	+150	
23	Max. permissible speed	rpm	20000	
24	Radial play		preloaded	
25	Max. axial load (dynamic)	N	7.5	
26	Max. force for press fits (static)	N	100	
27	Max. radial loading, 5mm from flange	N	25	
Other specifications				
28	Number of poles		2	
29	Number of phases		3	
30	Weight	g	366	

Connection

Connection		PTFE
Pin 1	+VCC	AWG20 red
Pin 2	GND	AWG20 black

Optional:

Pin 3	FR*	AWG28 yellow
-------	-----	--------------

*Reverse direction when connected to GND

Gearbox combinations

SVTG B 36
SVTG B 42

Caution
Incorrect lead connection will damage the controller!

Hello,
how can I help you?



TDS Precision Products GmbH
Industriestrasse 1a
CH-8157 Dielsdorf

T + 41 44 885 30 80
info@tds-pp.com
www.tds-pp.com