

# **ATOM EC Series**

## SVTN A 01

Coreless BLDC motors  
2 Pole Brushless DC Motors

# Contents

Model	W	Max rpm	Page
SVTN A 01-1220	up to 8	37.000	12
SVTN A 01-1230	up to 15	25.000	13
SVTN A 01-1630	up to 12	23.000	14
SVTN A 01-1636	up to 21	14.500	15
SVTN A 01-2040	up to 32	18.500	16
SVTN A 01-2232	up to 20	23.500	17
SVTN A 01-2240	up to 39	17.000	18
SVTN A 01-2248	up to 43	13.000	19
SVTN A 01-2260	up to 70	16.000	20
SVTN A 01-2446	up to 42	14.000	21
SVTN A 01-2453	up to 54	15.000	22
SVTN A 01-2845	up to 35	13.500	23
SVTN A 01-2854	up to 72	8.500	24
SVTN A 01-2864	up to 88	8.000	25
SVTN A 01-3242	up to 60	9.500	26
SVTN A 01-3260	up to 120	11.000	27
SVTN A 01-3270	up to 130	9.000	28
SVTN A 01-3660	up to 140	8.000	29
SVTN A 01-3670	up to 250	6.500	30
SVTN A 01-4058	up to 150	8.000	31
SVTN A 01-4070	up to 210	8.000	32
SVTN A 01-4088	up to 400	8.000	33

# ATOM EC Series

## SVTN A 01

Coreless BLDC motors  
2 Pole Brushless DC Motors



Cost effective



High power density



High efficiency



The benefits of this new technology are torque and high-speed when compared to same sizing. The lack of cogging, a reduced ripple torque, a linear correlation between speed and torque, low inertia bring performance to greater level in terms of power, dynamics by means of reduced weights and reduced dimensions.

Servotecnica's brushless motors apply hall sensors as a standard option, in addition to having the magnetic encoder option. Thanks to the sensors it is possible to control rotation speed, and, thanks to the lack of cogging, provide high performance and accuracy.

### Benefits

High power density	Long operational lifetime
High efficiency	No cogging
High reliability	Low inertia
Low noise	Robust
Low inductance	Cost-effective
Good heat dissipation	

## Product code

SVTN A 01 - ○○◇◇ - □□ - ◇ - ◇☆☆

A Series

01 Brushless DC Motors

○ Diameter

◇ Length

□ Nominal Voltage

◇ Shaft  
Single shaft - standard [S]; Double shaft [D]

◇ Sensor  
Sensorless [0]; Hall sensor [H]\*

☆☆ Customizations

\* Standard option from SVTN A 01 1630 onwards.

## Features

Winding	3 phase
Operating temperature	-30° +100° C
Connectors	JST PHR-8 1630; 1636; 2040; 2232; 2240; 2248; 2260; 2446; 2453; 2845; 2854; 2864  MOLEX 39-01-2080 3242; 3260; 3270; 3660; 3670; 4058; 4070; 4088
Magnets	Neodymium
Construction technology	Coreless winding system
Estimated operating lifetime	Lifetime depends on motor working conditions. It can reach 20.000 work hours under optimal conditions (almost 100 hours under extreme conditions).

## Feedback

Hall Sensor (standard)	
Magnetic encoder**	3 channels, from 25 to 1024 ppr

## Customizations

Hall Sensor (standard)	
Shaft	Length/Diameter/D-Cut/double shaft
Leadwire	PVC/Silicon/Teflon/UL No/Dimension/length
Connector	JST/MOLEX

\*\*See page 115 for more information

# Explanation of the performance diagram

The performance diagram shows the range of possible operating points of a drive at an ambient temperature of 25°C and includes both the operation in the thermally insulated and in the cooled state. The possible speed ranges are shown in dependence on the shaft torque.

The sector shown dashed describes potential operating points in which the drive can be engaged in intermittent operation or with increased cooling.

## Nominal torque [mNm]

Describes the max. continuous torque in the steady state at nominal voltage and with a thermal reduction of the  $R_{th2}$  value by 50 %. The continuous speed decreases linearly vis-a-vis the continuous torque. In the case of slotted flat brushless motors, this point is indicated with the motor mounted on a metal flange and is the same as MN. The continuous torque is independent of the continuous output power and can be exceeded if the motor is operated intermittently, for example, in S2 operation and/or if more cooling is applied.

## Nominal output power [W]

Describes the max. possible output power in continuous operation in steady state with a thermal reduction of the  $R_{th2}$  value by 50 %. The value is independent of the continuous torque, responds linearly to the cooling factor and can be exceeded if the motor is operated intermittently, for example, in S2 operation and/or if more cooling is applied.

## Nominal voltage curve [V]

The nominal voltage curve describes the operating points at  $U_N$  in the uncooled and cooled state. In steady state, the starting point corresponds to the no-load speed  $n_0$  of the drive. Operating points above this curve can be attained by an increase, operating points below by a reduction of the nominal voltage.

Additional Information for Slotted Brushless Motors The performance curves for slotted motors with a housing will be significantly different than the diagrams of the motors without housing. Typically motors without a housing will have a higher performance due to the effects of ambient air flow cooling.

\*The diagram based on ambient temperature of 25°.

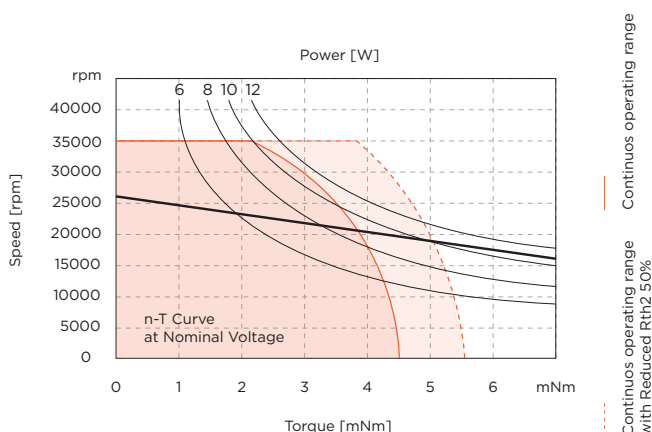

Example: Power diagram for rated values at continuous operation.

## Table explanation SVTN A Series

### Nominal voltage

It is the applied voltage between two powered phases in block commutation. All nominal data (lines 2 – 9) refer to this voltage. Lower and higher voltages are permissible, provided that limits are not exceeded.

### No load speed

It is the speed at which the unloaded motor runs with the nominal voltage applied. It is proportional to the applied voltage.

### No load current

This is the typical current that the unloaded motor draws when operating at nominal voltage. No load friction depends heavily on temperature. It decreases in extended operation and increases at lower temperatures.

### Nominal speed

It is the speed set for operation at nominal voltage and nominal torque at a motor temperature of 25°C.

### Nominal torque

It is the torque generated for operation at nominal voltage and nominal current at a motor temperature of 25°C. It is at the limit of the motor's continuous operation range. Higher torques heat up the winding too much.

### Nominal current

It is the current in the active phase the nominal torque at the given nominal speed (= max. permissible continuous load current). The maximum winding temperature is reached at 25°C ambient temperature in continuous operation with Nominal current.

### Stall torque

It is the linearly calculated load torque for motors that causes the shaft to stall at nominal voltage. This torque often cannot be achieved due to saturation effects.

### Stall current

It is the quotient from nominal voltage and the motor's terminal resistance. Stall current is equivalent to stall torque. With larger motors, Stall current cannot be reached due to the amplifier's current limits.

### Max. efficiency

It is the optimal relationship between input and output power at nominal voltage. Contact factory for more detail.

### Terminal resistance

It is determined by the resistance at 25 °C between two motor phase.

### Terminal inductance

It is the winding inductance between two motor phase.

### Torque constant

Represents the quotient from generated torque and applicable current.

### Speed constant

It indicates the theoretical no load speed per volt of applied voltage, disregarding friction losses.

### Speed/torque gradient

The speed/torque gradient is an indicator of the motor's performance. It is based on the quotient of ideal no load speed and ideal stall torque (tolerance  $\pm 20\%$ ).

### Mechanical time constant

It is the time required for the rotor to accelerate from standstill to 63% of its no load speed.

### Rotor moment of inertia

It is the mass moment of inertia of the rotor.

### Thermal resistance housing-ambient

Characteristic values of thermal contact resistance without additional heat sinking. Lines 17 and 18 combined define the maximum heating at a given power loss (load). Thermal resistance Rth2 on motors with metal flanges can decrease by up to 80% if the motor is coupled directly to a good heat-conducting.

### Thermal resistance winding-housing

Characteristic values of thermal contact resistance without additional heat sinking. Lines 17 and 18 combined define the maximum heating at a given power loss (load). Thermal resistance Rth2 on motors with metal flanges can decrease by up to 80% if the motor is coupled directly to a good heat-conducting.

### Thermal time constant winding

These are the typical reaction times for a temperature change of winding and motor. It can be seen that the motor reacts much more sluggishly in thermal terms than the winding. The values are calculated from the product of thermal capacity and given heat resistances.

### Thermal time constant motor

These are the typical reaction times for a temperature change of winding and motor. It can be seen that the motor reacts much more sluggishly in thermal terms than the winding. The values are calculated from the product of thermal capacity and given heat resistances.

### Ambient temperature

Operating temperature range. This derives from the heat reliability of the materials.

### Max. permissible winding temperature

Maximum permissible winding temperature.

### Max. permissible speed

It is the maximum recommended speed based on thermal and mechanical perspectives. A reduced service life can be expected at higher speeds.

### Radial play

Radial play is the bearing's radial movement

### Max. axial load (dynamics)

Dynamic: axial loading permissible in operation. If different values apply for traction and thrust, the smaller value is given.

### Max force for press fits (static)

Maximum axial force applying to the shaft at standstill if the force is not input at the other shaft end. This is not possible for motors with only one shaft end.

### Max. radial load

The value is given for a typical distance from the front flange. As the distance increases, this value decreases.

### Number of pole pairs

Number of north poles of the permanent magnet. The phase streams and commutation signals pass through per revolution p cycles. Servo-controllers require the correct details of the number of pole pairs.

### Number of phases

All motors have three phases.

### Weight



# ATOM EC Series SVTN A 01-1220

8 Watt

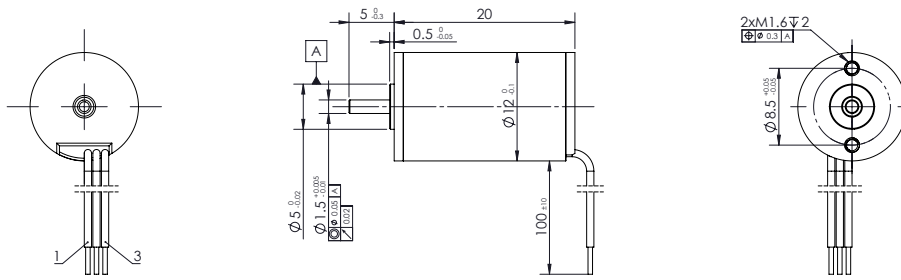
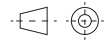

V 2.6.5

Values	Unit	SVTN A 01 1220-06..	1220-09..
--------	------	------------------------	-----------

Motor Data				
1	Nominal voltage	V	6	9
2	No load speed	rpm	25000	36890
3	No load current	mA	69	83
4	Nominal speed	rpm	16536	29888
5	Nominal torque	mNm	1,5	1,3
6	Nominal current	A	0,75	0,66
7	Stall torque	mNm	4,43	6,85
8	Stall current	A	2,07	3,1
9	Max. efficiency	%	66,8	70
Characteristics				
10	Terminal resistance*	$\Omega$	2,9	2,9
11	Terminal inductance*	mH	0,19	0,19
12	Torque constant	mNm/A	2,22	2,27
13	Speed constant	rpm/V	4310	4212
14	Speed/torque gradient	rpm/mNm	5642	5386
15	Mechanical time constant	ms	10	9,6
16	Rotor inertia	gcm <sup>2</sup>	0,17	0,17

Mechanical data		
17	Thermal resistance housing-ambient	38.3 K/W
18	Thermal resistance winding-housing	9.6 K/W
19	Thermal time constant winding	5 s
20	Thermal time constant motor	196 s
21	Ambient temperature	-30...+100°C
22	Max. permissible winding temperature	+125°C
23	Max. permissible speed	50000 rpm
24	Radial play	preloaded
25	Max. axial load (dynamic)	0,3
26	Max. force for press fits (static)	11N
27	Max. radial loading, 5mm from flange	4.3 N
Other specifications		
28	Number of poles	2
29	Number of phases	3
30	Weight	9,8g

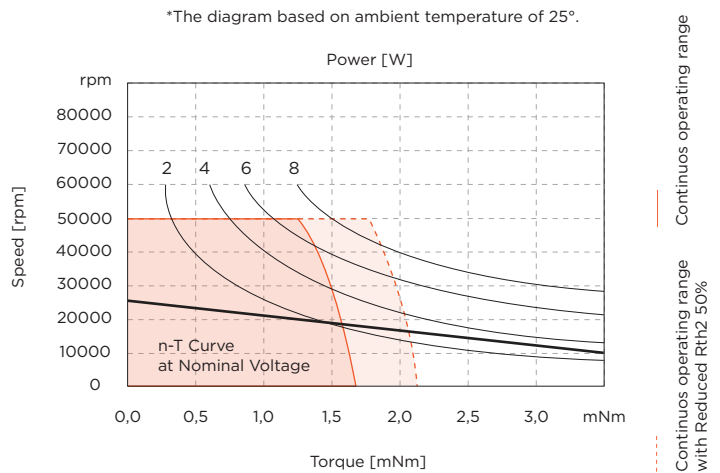

Connection			
Connection 0	(Sensorless)	PVC	
Pin 1	Motor winding MA	AWG28	yellow
Pin 2	Motor winding MB	AWG28	green
Pin 3	Motor winding MC	AWG28	blue

Gearbox combinations	
SVTG A 10*	
SVTG A 12*	
*On request	



ATOM EC Series  
**SVTN A 01-1230**

15 Watt



CORELESS BRUSHLESS servotecnica

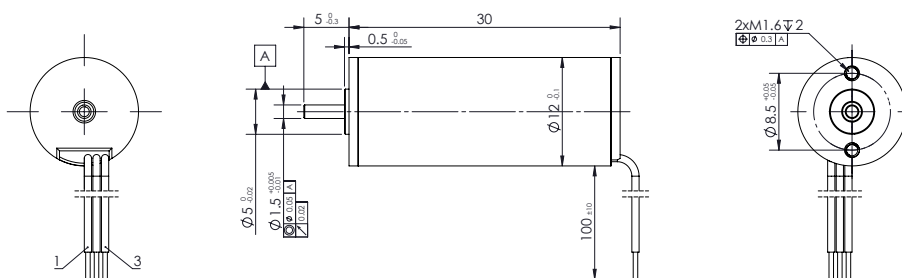

V 2.6.5

Values	Unit	SVTN A 01	1230-06..	1230-09..	1230-12..
--------	------	-----------	-----------	-----------	-----------

Motor Data					
1	Nominal voltage	V	6	9	12
2	No load speed	rpm	25310	25100	24930
3	No load current	mA	122	90	72
4	Nominal speed	rpm	20719	20565	20449
5	Nominal torque	mNm	3	3	3
6	Nominal current	A	1,47	0,98	0,74
7	Stall torque	mNm	16,5	16,6	16,7
8	Stall current	A	7,55	5,03	3,77
9	Max. efficiency	%	76,2	75	74,3
Characteristics					
10	Terminal resistance*	Ω	0,8	1,79	3,18
11	Terminal inductance*	mH	0,02	0,04	0,08
12	Torque constant	mNm/A	2,23	3,36	4,51
13	Speed constant	rpm/V	4288	2840	2118
14	Speed/torque gradient	rpm/mNm	1530	1512	1494
15	Mechanical time constant	ms	5,1	5,1	5
16	Rotor inertia	gcm <sup>2</sup>	0,32	0,32	0,32

Mechanical data		
17	Thermal resistance housing-ambient	28.4 K/W
18	Thermal resistance winding-housing	7.1 K/W
19	Thermal time constant winding	4 s
20	Thermal time constant motor	240 s
21	Ambient temperature	-30...+100°C
22	Max. permissible winding temperature	+125°C
23	Max. permissible speed	50000 rpm
24	Radial play	preloaded
25	Max. axial load (dynamic)	0,3
26	Max. force for press fits (static)	11N
27	Max. radial loading, 5mm from flange	4.3 N
Other specifications		
28	Number of poles	2
29	Number of phases	3
30	Weight	16.3 g

\*The diagram based on ambient temperature of 25°.

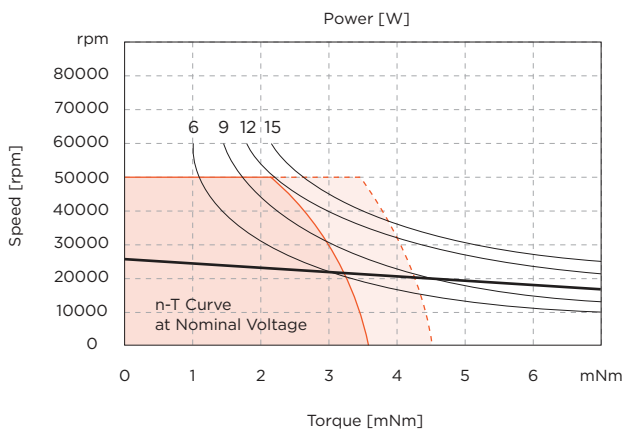

Continuous operating range  
Continuous operating range with Reduced  $\eta$  50%

**Connection**

Connection 0	(Sensorless)	PVC
Pin 1	Motor winding MA	AWG28 yellow
Pin 2	Motor winding MB	AWG28 green
Pin 3	Motor winding MC	AWG28 blue

**Gearbox combinations**

- SVTG A 10\*
- SVTG A 12\*

\*On request





# ATOM EC Series SVTN A 01-1630

12 Watt

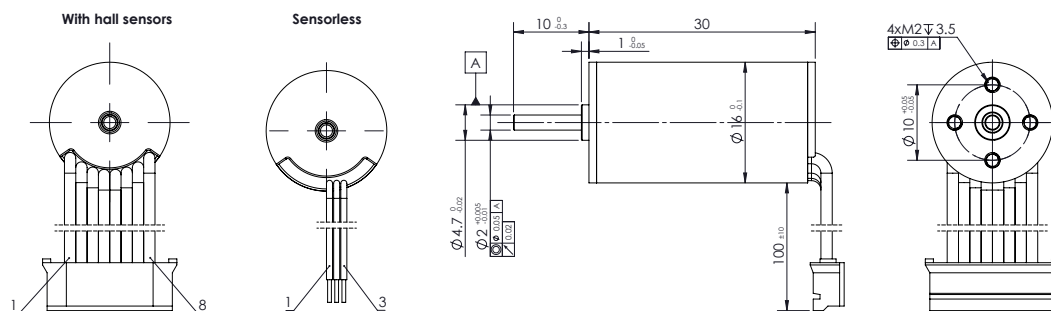

V 2.6.5

Values	Unit	SVTN A 01 1630-12..	1630-18..	1630-24..	
<b>Motor Data</b>					
1	Nominal voltage	V	12	18	24
2	No load speed	rpm	23220	23511	23760
3	No load current	mA	210	150	100
4	Nominal speed	rpm	19138	19506	19203
5	Nominal torque	mNm	3,5	3,5	3,5
6	Nominal current	A	0,95	0,65	0,48
7	Stall torque	mNm	19,9	20,5	18,2
8	Stall current	A	4,44	3,1	2,09
9	Max. efficiency	%	61,3	60,9	61
<b>Characteristics</b>					
10	Terminal resistance*	$\Omega$	2,7	5,8	11,5
11	Terminal inductance*	mH	0,08	0,17	0,33
12	Torque constant	mNm/A	4,7	6,96	9,18
13	Speed constant	rpm/V	2031	1373	1040
14	Speed/torque gradient	rpm/mNm	1166	1144	1302
15	Mechanical time constant	ms	5,8	5,7	6,5
16	Rotor inertia	gcm <sup>2</sup>	0,48	0,48	0,48
<b>Mechanical data</b>					
17	Thermal resistance housing-ambient	20.0 K/W			
18	Thermal resistance winding-housing	8.8 K/W			
19	Thermal time constant winding	8 s			
20	Thermal time constant motor	236 s			
21	Ambient temperature	-30...+100°C			
22	Max. permissible winding temperature	+150°C			
23	Max. permissible speed	35000 rpm			
24	Radial play	preloaded			
25	Max. axial load (dynamic)	1.3 N			
26	Max. force for press fits (static)	15 N			
27	Max. radial loading, 5mm from flange	5 N			
<b>Other specifications</b>					
28	Number of poles	2			
29	Number of phases	3			
30	Weight	25 g			

\*The diagram based on ambient temperature of 25°.

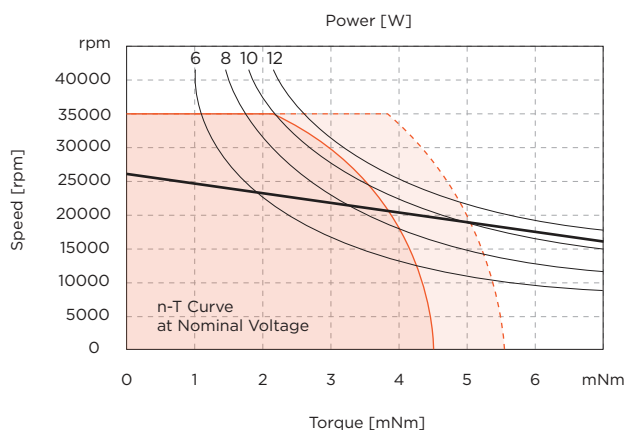

Continuous operating range  
Continuous operating range with Reduced Rth2 50%

### Connection

Connection H (Sensor)	PVC
Pin 1	Vhall 3-18 VDC
Pin 2	Hall sensor HA
Pin 3	Hall sensor HB
Pin 4	Hall sensor HC
Pin 5	GND
Pin 6	Motor winding MA
Pin 7	Motor winding MB
Pin 8	Motor winding MC
Connector	JST PHR-8
Connection O (Sensorless)	
Pin 1	Motor winding MA
Pin 2	Motor winding MB
Pin 3	Motor winding MC

### Drive combinations

Hall sensor	Encoder
SVTE-A-E40	SVTE-A-E45
SVTE-A-E50	SVTE-A-E55
Encoder combinations	
EN 16A	EN 16AL
Gearbox combinations	
SVTG A 16	



ATOM EC Series  
SVTN A 01-1636

21 Watt



servotecnica  
CORELESS  
BRUSHLESS

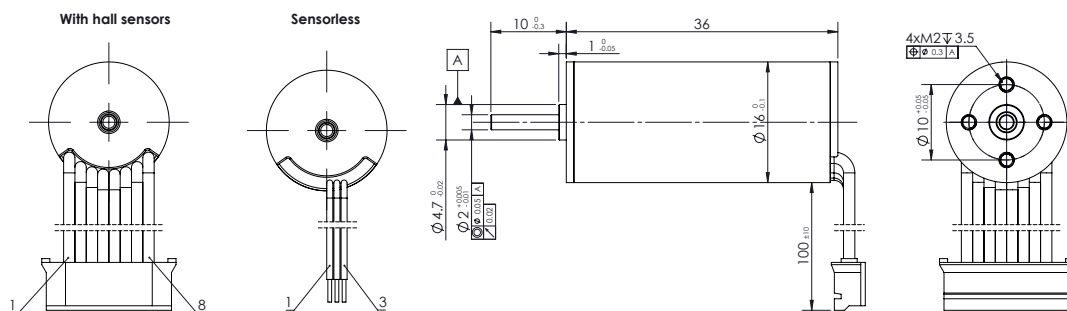

V 2.6.5

Values	Unit	SVTN A 01 1636-06..	1636-09..	1636-12..	1636-24..
--------	------	------------------------	-----------	-----------	-----------

Motor Data						
1	Nominal voltage	V	6	9	12	24
2	No load speed	rpm	13835	14533	14460	14668
3	No load current	mA	150	110	70	50
4	Nominal speed	rpm	11412	11930	11615	12005
5	Nominal torque	mNm	6	6	6	6
6	Nominal current	A	1,62	1,14	0,84	0,44
7	Stall torque	mNm	34,3	33,5	30,5	33
8	Stall current	A	8,57	5,88	3,99	2,21
9	Max. efficiency	%	75,3	74,5	75,3	72,2
Characteristics						
10	Terminal resistance*	Ω	0,7	1,53	3,01	10,8
11	Terminal inductance*	mH	0,04	0,08	0,15	0,81
12	Torque constant	mNm/A	4,07	5,8	7,79	15,3
13	Speed constant	rpm/V	2347	1646	1227	625
14	Speed/torque gradient	rpm/mNm	404	434	474	444
15	Mechanical time constant	ms	2,6	2,8	3,1	2,9
16	Rotor inertia	gcm <sup>2</sup>	0,62	0,62	0,62	0,62

Mechanical data		
17	Thermal resistance housing-ambient	17,1 K/W
18	Thermal resistance winding-housing	5,3 K/W
19	Thermal time constant winding	6 s
20	Thermal time constant motor	252 s
21	Ambient temperature	-30...+100°C
22	Max. permissible winding temperature	+150°C
23	Max. permissible speed	35000 rpm
24	Radial play	preloaded
25	Max. axial load (dynamic)	1,3 N
26	Max. force for press fits (static)	15 N
27	Max. radial loading, 5mm from flange	5 N
Other specifications		
28	Number of poles	2
29	Number of phases	3
30	Weight	32 g

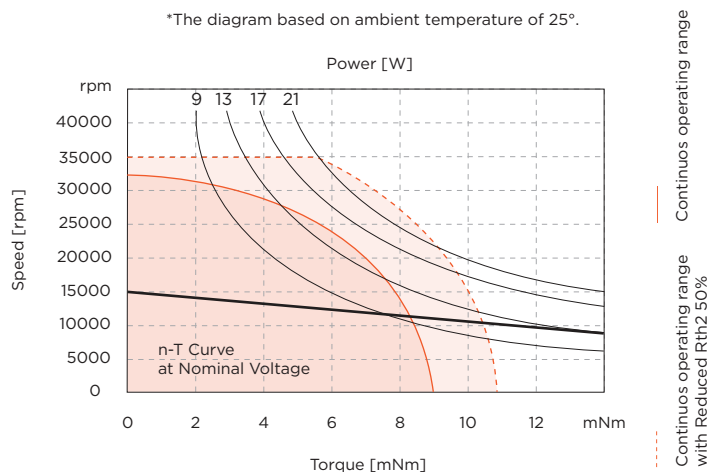

Connection

Connection H (Sensor)	PVC
Pin 1	Vhall 3-18 VDC
Pin 2	Hall sensor HA
Pin 3	Hall sensor HB
Pin 4	Hall sensor HC
Pin 5	GND
Pin 6	Motor winding MA
Pin 7	Motor winding MB
Pin 8	Motor winding MC
Connector	JST PHR-8
Connection O (Sensorless)	
Pin 1	Motor winding MA
Pin 2	Motor winding MB
Pin 3	Motor winding MC

Drive combinations

Hall sensor	Encoder
SVTE-A-E40	SVTE-A-E45
SVTE-A-E50	SVTE-A-E55
Encoder combinations	EN 16A
Gearbox combinations	SVTG A 16



# ATOM EC Series SVTN A 01-2040

32 Watt

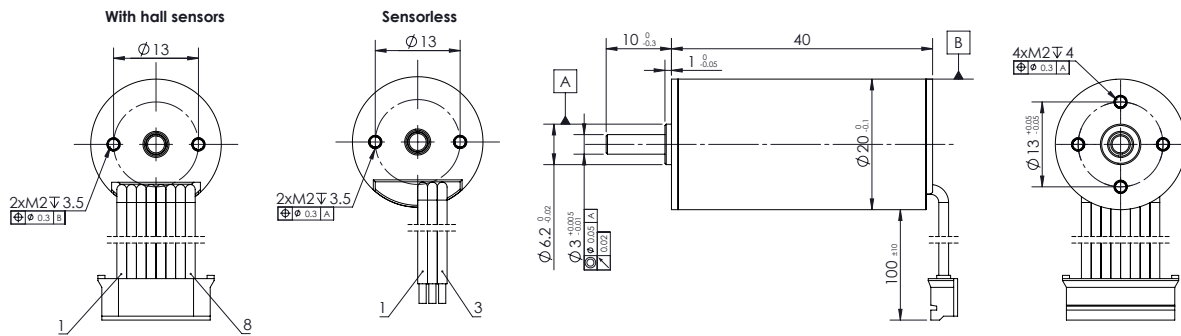

V 2.6.5

Values	Unit	SVTN A 01 2040-12..	2040-18..	2040-24..	2040-36..	
<b>Motor Data</b>						
1	Nominal voltage	V	12	18	24	36
2	No load speed	rpm	17780	18360	18500	18880
3	No load current	mA	149	137	105	83
4	Nominal speed	rpm	15083	16171	16042	16164
5	Nominal torque	mNm	10	10	10	10
6	Nominal current	A	1,72	1,22	0,93	0,64
7	Stall torque	mNm	65,9	83,9	75,3	69,5
8	Stall current	A	10,5	9,23	6,28	3,98
9	Max. efficiency	%	77,6	77,1	75,8	73,2
<b>Characteristics</b>						
10	Terminal resistance*	$\Omega$	1,14	1,95	3,82	9,04
11	Terminal inductance*	mH	0,08	0,17	0,3	0,62
12	Torque constant	mNm/A	6,35	9,22	12,18	17,83
13	Speed constant	rpm/V	1503	1035	784	536
14	Speed/torque gradient	rpm/mNm	270	219	246	272
15	Mechanical time constant	ms	6,4	5,2	5,8	6,4
16	Rotor inertia	gcm <sup>2</sup>	2,3	2,3	2,3	2,3
<b>Mechanical data</b>						
17	Thermal resistance housing-ambient	K/W	13,8			
18	Thermal resistance winding-housing	K/W	4,3			
19	Thermal time constant winding	s	8			
20	Thermal time constant motor	s	366			
21	Ambient temperature	°C	-30...+100			
22	Max. permissible winding temperature	°C	+150			
23	Max. permissible speed	rpm	35000			
24	Radial play		preloaded			
25	Max. axial load (dynamic)	N	3,5			
26	Max. force for press fits (static)	N	44			
27	Max. radial loading, 5mm from flange	N	15			
<b>Other specifications</b>						
28	Number of poles		2			
29	Number of phases		3			
30	Weight	g	56			

\*The diagram based on ambient temperature of 25°.

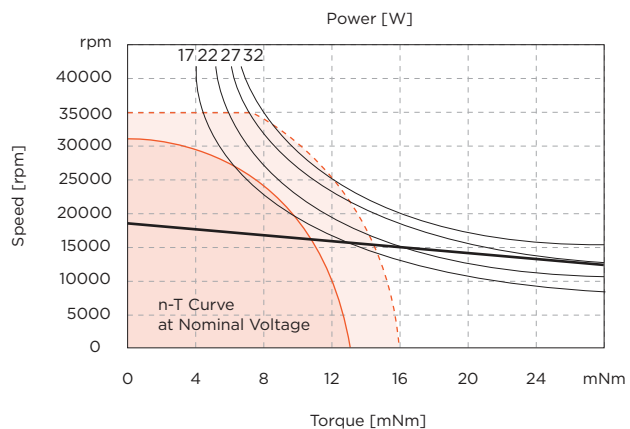

Continuous operating range  
Continuous operating range with Reduced Rtn2 50%

## Connection

Connection H (Sensor)	PVC		
Pin 1	Vhall 3-18 VDC	AWG26	black
Pin 2	Hall sensor HA	AWG26	black
Pin 3	Hall sensor HB	AWG26	black
Pin 4	Hall sensor HC	AWG26	black
Pin 5	GND	AWG26	black
Pin 6	Motor winding MA	AWG26	black
Pin 7	Motor winding MB	AWG26	black
Pin 8	Motor winding MC	AWG26	black
Connector	JST	PHR-8	
Connection O (Sensorless)			
Pin 1	Motor winding MA	AWG26	yellow
Pin 2	Motor winding MB	AWG26	green
Pin 3	Motor winding MC	AWG26	blue

## Drive combinations

Hall sensor	Encoder
SVTE-A-E40	SVTE-A-E45
SVTE-A-E50	SVTE-A-E55
Encoder combinations	
EN 22A	EN 22AL
Gearbox combinations	
SVTG B 22	



ATOM EC Series  
**SVTN A 01-2232**

20 Watt

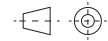

CORELESS BRUSHLESS servotecnica

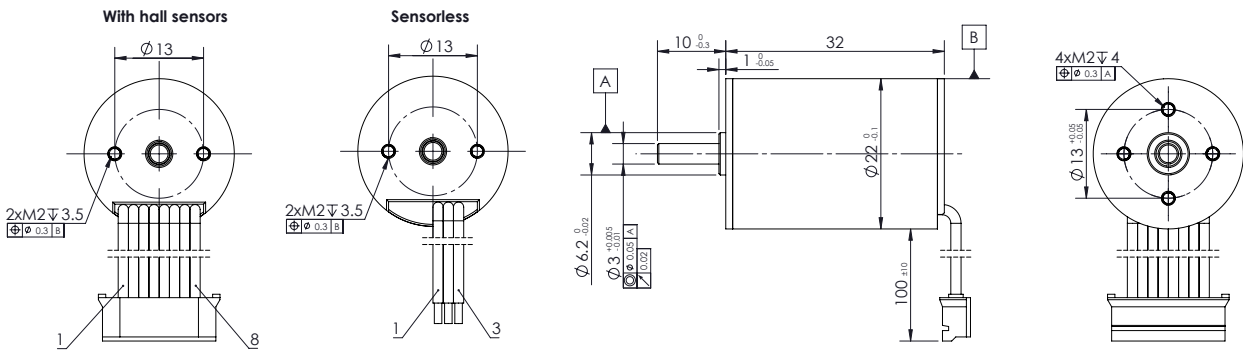

V 2.6.5

Values	Unit	SVTN A 01 2232-06..	2232-12..	2232-18..	2232-24..
--------	------	------------------------	-----------	-----------	-----------

Motor Data						
1	Nominal voltage	V	6	12	18	24
2	No load speed	rpm	11700	11184	12080	12164
3	No load current	mA	230	150	86	60
4	Nominal speed	rpm	9585	9023	9937	9358
5	Nominal torque	mNm	6	6	6	6
6	Nominal current	A	1.5	0.76	0.52	0.39
7	Stall torque	mNm	33.2	31.1	33.8	26
8	Stall current	A	7.23	3.32	2.55	1.5
9	Max. efficiency	%	67.5	62	66.6	64
Characteristics						
10	Terminal resistance*	Ω	0.83	3.61	7.07	16
11	Terminal inductance*	mH	0.08	0.28	0.66	1.72
12	Torque constant	mNm/A	4.74	9.78	13.7	18.1
13	Speed constant	rpm/V	2014	976	695	528
14	Speed/torque gradient	rpm/mNm	353	360	357	468
15	Mechanical time constant	ms	5.5	5.6	5.6	7.3
16	Rotor inertia	gcm <sup>2</sup>	1.5	1.5	1.5	1.5

Mechanical data		
17	Thermal resistance housing-ambient	15.2 K/W
18	Thermal resistance winding-housing	6.0 K/W
19	Thermal time constant winding	11 s
20	Thermal time constant motor	383 s
21	Ambient temperature	-30...+100°C
22	Max. permissible winding temperature	+150°C
23	Max. permissible speed	35000 rpm
24	Radial play	preloaded
25	Max. axial load (dynamic)	3.5 N
26	Max. force for press fits (static)	44 N
27	Max. radial loading, 5mm from flange	15 N
Other specifications		
28	Number of poles	2
29	Number of phases	3
30	Weight	48 g

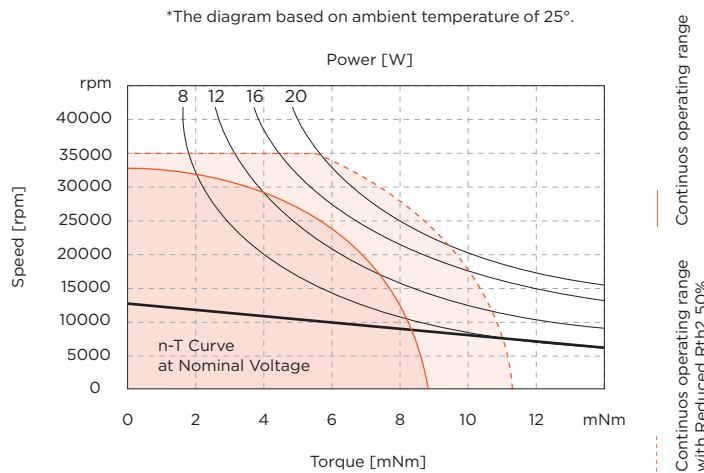

**Connection**

Connection H	(Sensor)	PVC	
Pin 1	Vhall 3-18 VDC	AWG26	black
Pin 2	Hall sensor HA	AWG26	black
Pin 3	Hall sensor HB	AWG26	black
Pin 4	Hall sensor HC	AWG26	black
Pin 5	GND	AWG26	black
Pin 6	Motor winding MA	AWG26	black
Pin 7	Motor winding MB	AWG26	black
Pin 8	Motor winding MC	AWG26	black
Connector			
JST	PHR-8		
Connection O (Sensorless)			
Pin 1	Motor winding MA	AWG26	yellow
Pin 2	Motor winding MB	AWG26	green
Pin 3	Motor winding MC	AWG26	blue

**Drive combinations**

Hall sensors	Encoder
SVTE-A-E40	SVTE-A-E45
SVTE-A-E50	SVTE-A-E55

**Encoder combinations**

EN 22A  
EN 22AL

**Gearbox combinations**

SVTG B 22  
SVTG B 24



# ATOM EC Series SVTN A 01-2240

39 Watt

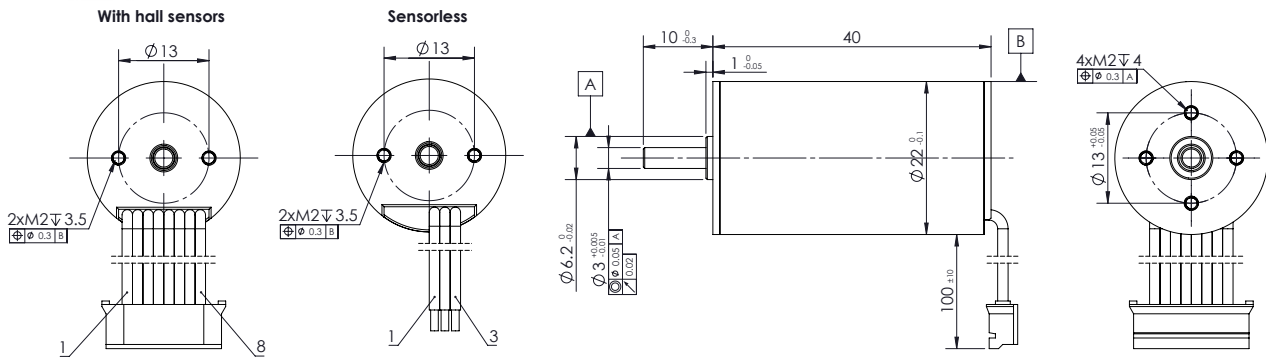
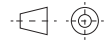

V 2.6.5

Values	Unit	SVTN A 01 2240-12..	2240-24..	2240-30..	2240-36..	
<b>Motor Data</b>						
1	Nominal voltage	V	12	24	30	36
2	No load speed	rpm	16748	16768	16713	16679
3	No load current	mA	183	115	87	73
4	Nominal speed	rpm	14354	14337	14360	14128
5	Nominal torque	mNm	12	12	12	12
6	Nominal current	A	1,96	1,01	0,8	0,67
7	Stall torque	mNm	83,9	82,8	85,2	78,5
8	Stall current	A	12,6	6,28	5,15	3,95
9	Max. efficiency	%	77,4	74,8	75,7	74,7
<b>Characteristics</b>						
10	Terminal resistance*	$\Omega$	0,95	3,82	5,83	9,11
11	Terminal inductance*	mH	0,07	0,28	0,44	0,64
12	Torque constant	mNm/A	6,74	13,4	16,9	20,2
13	Speed constant	rpm/V	1416	712	567	472
14	Speed/torque gradient	rpm/mNm	200	203	196	213
15	Mechanical time constant	ms	4,7	4,8	4,7	5,1
16	Rotor inertia	gcm <sup>2</sup>	2,3	2,3	2,3	2,3
<b>Mechanical data</b>						
17	Thermal resistance housing-ambient	K/W	12,7			
18	Thermal resistance winding-housing	K/W	5,0			
19	Thermal time constant winding	s	12			
20	Thermal time constant motor	s	420			
21	Ambient temperature	°C	-30...+100			
22	Max. permissible winding temperature	°C	+150			
23	Max. permissible speed	rpm	35000			
24	Radial play		preloaded			
25	Max. axial load (dynamic)	N	3,5			
26	Max. force for press fits (static)	N	44			
27	Max. radial loading, 5mm from flange	N	15			
<b>Other specifications</b>						
28	Number of poles		2			
29	Number of phases		3			
30	Weight	g	64			

\*The diagram based on ambient temperature of 25°.

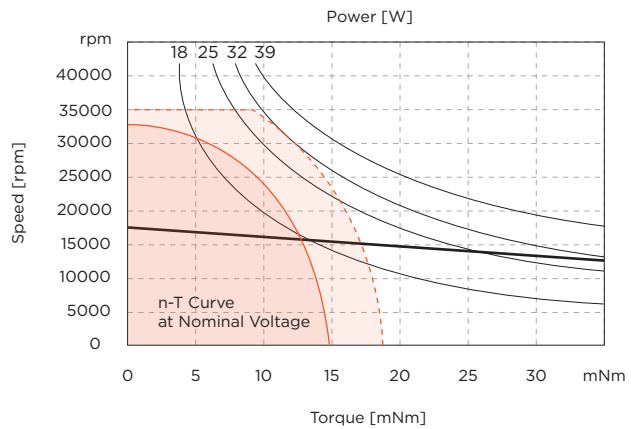

Continuous operating range  
Continuous operating range with Reduced Rtn2 50%

## Connection

Connection H (Sensor)	PVC		
Pin 1	Vhall 3-18 VDC	AWG26	black
Pin 2	Hall sensor HA	AWG26	black
Pin 3	Hall sensor HB	AWG26	black
Pin 4	Hall sensor HC	AWG26	black
Pin 5	GND	AWG26	black
Pin 6	Motor winding MA	AWG26	black
Pin 7	Motor winding MB	AWG26	black
Pin 8	Motor winding MC	AWG26	black
Connector			
JST	PHR-8		
Connection O (Sensorless)			
Pin 1	Motor winding MA	AWG26	yellow
Pin 2	Motor winding MB	AWG26	green
Pin 3	Motor winding MC	AWG26	blue

## Drive combinations

Hall sensors	Encoder
SVTE-A-E40	SVTE-A-E45
SVTE-A-E50	SVTE-A-E55

## Encoder combinations

EN 22A  
EN 22AL

## Gearbox combinations

SVTG B 22  
SVTG B 24



ATOM EC Series  
SVTN A 01-2248

43 Watt

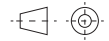

CORELESS  
BRUSHLESS

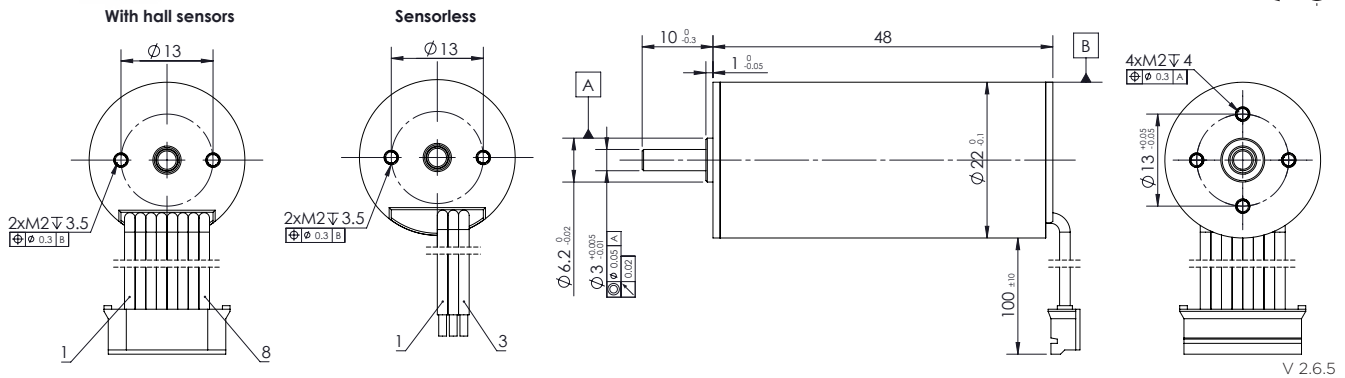

Values	Unit	SVTN A 01 2248-12..	2248-24..	2248-36..	2248-48..
--------	------	------------------------	-----------	-----------	-----------

Motor Data						
1	Nominal voltage	V	12	24	36	48
2	No load speed	rpm	13004	12930	13390	13641
3	No load current	mA	179	102	82	69
4	Nominal speed	rpm	11426	11413	11749	12159
5	Nominal torque	mNm	18	18	18	18
6	Nominal current	A	2,24	1,13	0,79	0,61
7	Stall torque	mNm	148	153	147	166
8	Stall current	A	17,2	8,88	5,88	5,07
9	Max. efficiency	%	80,6	79,7	77,8	78
Characteristics						
10	Terminal resistance*	Ω	0,7	2,71	6,12	9,47
11	Terminal inductance*	mH	0,07	0,28	0,58	0,97
12	Torque constant	mNm/A	8,72	17,5	25,3	33,1
13	Speed constant	rpm/V	1095	545	377	288
14	Speed/torque gradient	rpm/mNm	87,7	84,3	91,2	82,3
15	Mechanical time constant	ms	2,9	2,8	3	2,7
16	Rotor inertia	gcm <sup>2</sup>	3,1	3,1	3,1	3,1

Mechanical data		
17	Thermal resistance housing-ambient	11.8 K/W
18	Thermal resistance winding-housing	4.7 K/W
19	Thermal time constant winding	21 s
20	Thermal time constant motor	504 s
21	Ambient temperature	-30...+100°C
22	Max. permissible winding temperature	+150°C
23	Max. permissible speed	30000 rpm
24	Radial play	preloaded
25	Max. axial load (dynamic)	3.5 N
26	Max. force for press fits (static)	44 N
27	Max. radial loading, 5mm from flange	15 N
Other specifications		
28	Number of poles	2
29	Number of phases	3
30	Weight	85 g

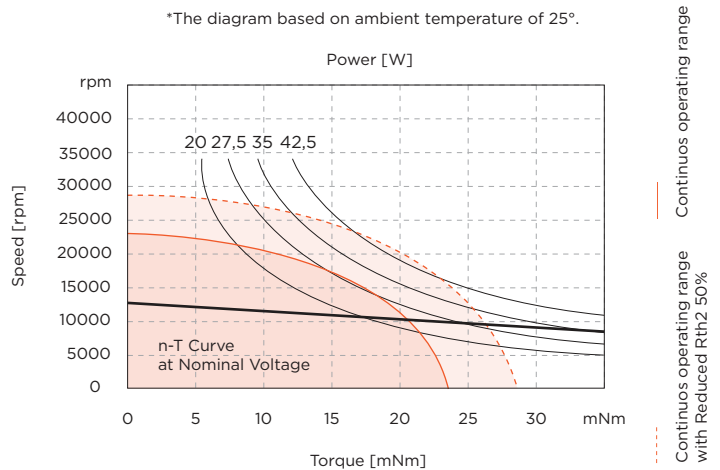

Connection

Connection H (Sensor)			
Connection H	(Sensor)	PVC	
Pin 1	Vhall 3-18 VDC	AWG26	black
Pin 2	Hall sensor HA	AWG26	black
Pin 3	Hall sensor HB	AWG26	black
Pin 4	Hall sensor HC	AWG26	black
Pin 5	GND	AWG26	black
Pin 6	Motor winding MA	AWG26	black
Pin 7	Motor winding MB	AWG26	black
Pin 8	Motor winding MC	AWG26	black
Connector			
JST	PHR-8		
Connection O (Sensorless)			
Pin 1	Motor winding MA	AWG26	yellow
Pin 2	Motor winding MB	AWG26	green
Pin 3	Motor winding MC	AWG26	blue

Drive combinations

Hall sensors	Encoder
SVTE-A-E40	SVTE-A-E45
SVTE-A-E50	SVTE-A-E55

Encoder combinations

- EN 22A
- EN 22AL

Gearbox combinations

- SVTG B 22
- SVTG B 24



# ATOM EC Series SVTN A 01-2260

70 Watt

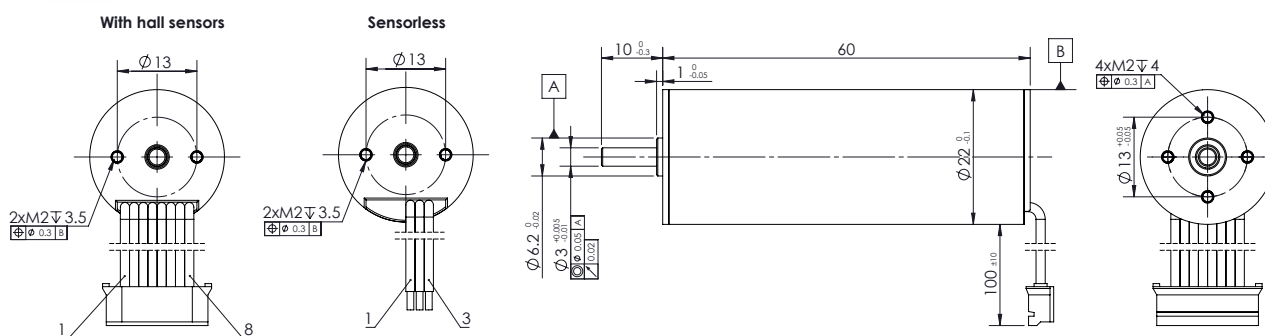

V 2.6.5

Values	Unit	SVTN A 01 2260-12..	2260-24..	2260-36..	2260-48..	
<b>Motor Data</b>						
1	Nominal voltage	V	12	24	36	48
2	No load speed	rpm	16360	16086	16030	16200
3	No load current	mA	440	230	170	110
4	Nominal speed	rpm	14517	14441	14364	14530
5	Nominal torque	mNm	28	28	28	28
6	Nominal current	A	4,49	2,22	1,49	1,11
7	Stall torque	mNm	249	274	269	272
8	Stall current	A	36,4	19,7	12,9	9,82
9	Max. efficiency	%	79,2	79,5	78,4	79,9
<b>Characteristics</b>						
10	Terminal resistance*	$\Omega$	0,33	1,22	2,79	4,89
11	Terminal inductance*	mH	0,03	0,13	0,3	0,52
12	Torque constant	mNm/A	6,92	14,1	21,2	28
13	Speed constant	rpm/V	1380	678	451	341
14	Speed/torque gradient	rpm/mNm	65,8	58,8	59,5	59,7
15	Mechanical time constant	ms	3,1	2,8	2,8	2,8
16	Rotor inertia	gcm <sup>2</sup>	4,5	4,5	4,5	4,5

<b>Mechanical data</b>		
17	Thermal resistance housing-ambient	7.6 K/W
18	Thermal resistance winding-housing	4.6 K/W
19	Thermal time constant winding	29 s
20	Thermal time constant motor	533 s
21	Ambient temperature	-30...+100°C
22	Max. permissible winding temperature	+150°C
23	Max. permissible speed	30000 rpm
24	Radial play	preloaded
25	Max. axial load (dynamic)	3.5 N
26	Max. force for press fits (static)	44 N
27	Max. radial loading, 5mm from flange	15 N
<b>Other specifications</b>		
28	Number of poles	2
29	Number of phases	3
30	Weight	122 g

\*The diagram based on ambient temperature of 25°.

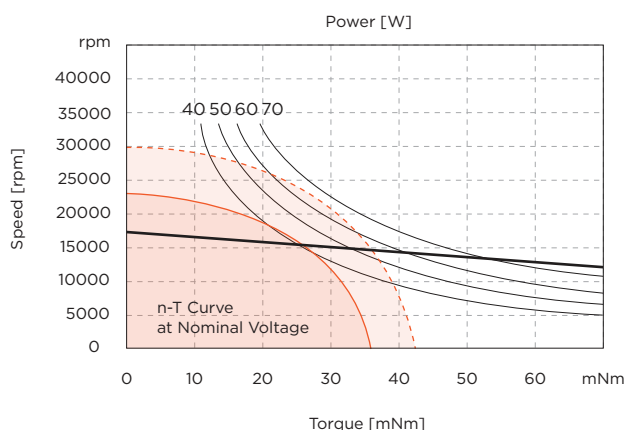

Continuous operating range  
Continuous operating range with Reduced Rtn2 50%

## Connection

Connection H	(Sensor)	PVC	
Pin 1	Vhall 3-18 VDC	AWG26	black
Pin 2	Hall sensor HA	AWG26	black
Pin 3	Hall sensor HB	AWG26	black
Pin 4	Hall sensor HC	AWG26	black
Pin 5	GND	AWG26	black
Pin 6	Motor winding MA	AWG26	black
Pin 7	Motor winding MB	AWG26	black
Pin 8	Motor winding MC	AWG26	black
Connector			
JST	PHR-8		
Connection O	(Sensorless)		
Pin 1	Motor winding MA	AWG26	yellow
Pin 2	Motor winding MB	AWG26	green
Pin 3	Motor winding MC	AWG26	blue

## Drive combinations

<b>Hall sensors</b>	<b>Encoder</b>
SVTE-A-E40	SVTE-A-E45
SVTE-A-E50	SVTE-A-E55

## Encoder combinations

EN 22A  
EN 22AL

## Gearbox combinations

SVTG B 22  
SVTG B 24



ATOM EC Series  
SVTN A 01-2446

42 Watt



CORELESS  
BRUSHLESS

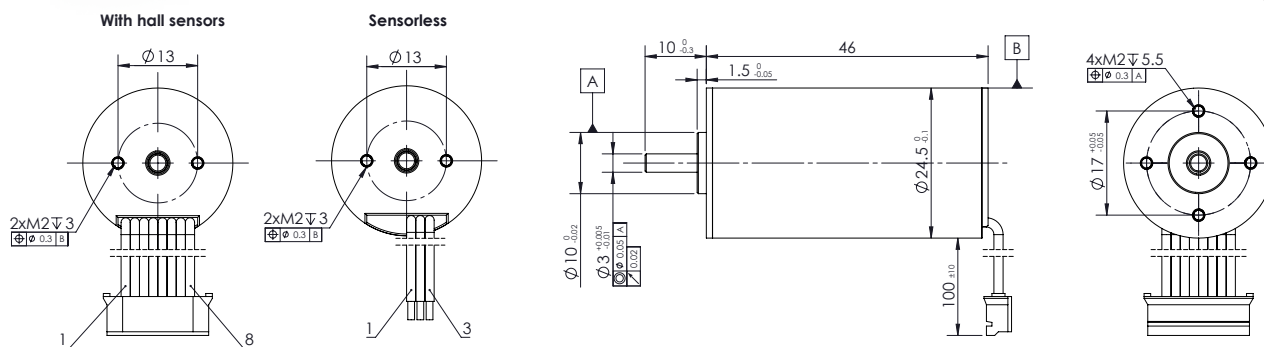

V 2.6.5

Values	Unit	SVTN A 01 2446-12..	2446-24..	2446-36..	2446-48..
--------	------	------------------------	-----------	-----------	-----------

Motor Data						
1	Nominal voltage	V	12	24	36	48
2	No load speed	rpm	14150	13872	13920	13870
3	No load current	mA	249	124	106	79
4	Nominal speed	rpm	12678	12487	12662	12446
5	Nominal torque	mNm	18	18	18	18
6	Nominal current	A	2,5	1,23	0,84	0,63
7	Stall torque	mNm	173	180	199	175
8	Stall current	A	21,9	11,2	8,28	5,46
9	Max. efficiency	%	79,8	80	78,6	77,4
Characteristics						
10	Terminal resistance*	Ω	0,55	2,15	4,35	8,79
11	Terminal inductance*	mH	0,07	0,29	0,62	1,14
12	Torque constant	mNm/A	8,01	16,3	24,4	32,6
13	Speed constant	rpm/V	1193	584	392	293
14	Speed/torque gradient	rpm/mNm	81,8	76,9	69,9	79,1
15	Mechanical time constant	ms	3,6	3,4	3,1	3,5
16	Rotor inertia	gcm <sup>2</sup>	4,2	4,2	4,2	4,2

Mechanical data		
17	Thermal resistance housing-ambient	11.6 K/W
18	Thermal resistance winding-housing	5.6 K/W
19	Thermal time constant winding	30 s
20	Thermal time constant motor	557 s
21	Ambient temperature	-30...+100°C
22	Max. permissible winding temperature	+150°C
23	Max. permissible speed	30000 rpm
24	Radial play	preloaded
25	Max. axial load (dynamic)	3.5 N
26	Max. force for press fits (static)	44 N
27	Max. radial loading, 5mm from flange	15 N

Other specifications		
28	Number of poles	2
29	Number of phases	3
30	Weight	92 g

\*The diagram based on ambient temperature of 25°.

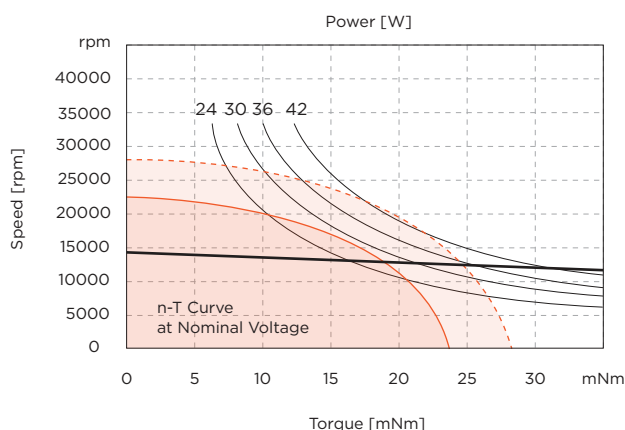

Continuous operating range  
Continuous operating range with Reduced Rtn2 50%

Connection

Connection H (Sensor)	PVC
Pin 1	Vhall 3-18 VDC
Pin 2	Hall sensor HA
Pin 3	Hall sensor HB
Pin 4	Hall sensor HC
Pin 5	GND
Pin 6	Motor winding MA
Pin 7	Motor winding MB
Pin 8	Motor winding MC
Connector	JST PHR-8
Connection O (Sensorless)	
Pin 1	Motor winding MA
Pin 2	Motor winding MB
Pin 3	Motor winding MC

Drive combinations

Hall sensors	Encoder
SVTE-A-E40	SVTE-A-E45
SVTE-A-E50	SVTE-A-E55

Encoder combinations

- EN 22A
- EN 22AL

Gearbox combinations

- SVTG B 24
- SVTG B 28





# ATOM EC Series SVTN A 01-2453

54 Watt

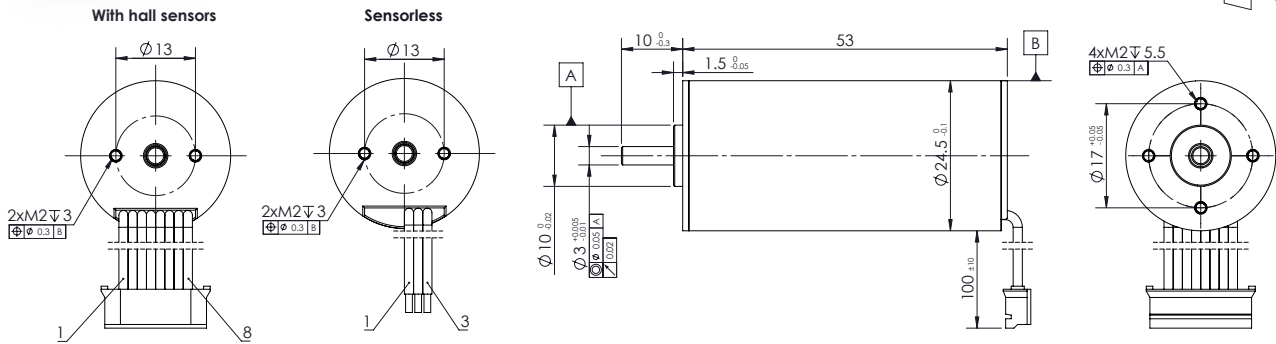

V 2.6.5

Values	Unit	SVTN A 01 2453-12..	2453-24..	2453-36..	2453-48..	
<b>Motor Data</b>						
1	Nominal voltage	V	12	24	36	48
2	No load speed	rpm	15083	15398	15202	15310
3	No load current	mA	308	156	115	94
4	Nominal speed	rpm	13938	14347	14211	14263
5	Nominal torque	mNm	20	20	20	20
6	Nominal current	A	2,96	1,51	1,01	0,77
7	Stall torque	mNm	263	293	307	293
8	Stall current	A	35,3	20	13,8	9,96
9	Max. efficiency	%	82,2	83,1	82,6	81,5
<b>Characteristics</b>						
10	Terminal resistance*	Ω	0,34	1,2	2,61	4,82
11	Terminal inductance*	mH	0,05	0,19	0,44	0,76
12	Torque constant	mNm/A	7,53	14,8	22,4	29,7
13	Speed constant	rpm/V	1268	647	426	322
14	Speed/torque gradient	rpm/mNm	57,2	52,5	49,6	52,3
15	Mechanical time constant	ms	3,5	3,2	3,1	3,2
16	Rotor inertia	gcm <sup>2</sup>	5,9	5,9	5,9	5,9
<b>Mechanical data</b>						
17	Thermal resistance housing-ambient		10.2 K/W			
18	Thermal resistance winding-housing		6.4 K/W			
19	Thermal time constant winding		36 s			
20	Thermal time constant motor		555 s			
21	Ambient temperature		-30...+100°C			
22	Max. permissible winding temperature		+150°C			
23	Max. permissible speed		30000 rpm			
24	Radial play		preloaded			
25	Max. axial load (dynamic)		3.5 N			
26	Max. force for press fits (static)		44 N			
27	Max. radial loading, 5mm from flange		15 N			
<b>Other specifications</b>						
28	Number of poles		2			
29	Number of phases		3			
30	Weight		110 g			

\*The diagram based on ambient temperature of 25°.

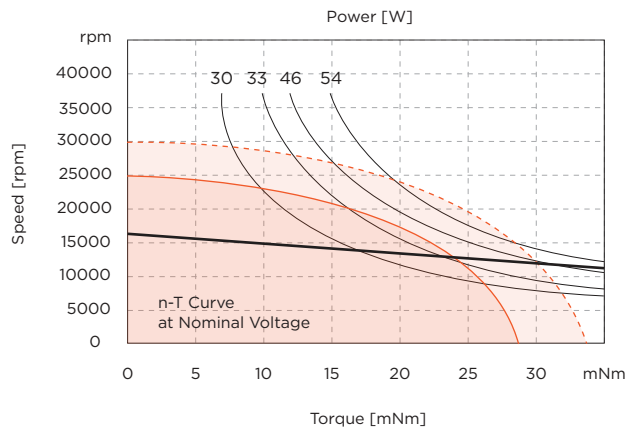

Continuous operating range  
Continuous operating range with Reduced Tm2 50%

## Connection

Connection H	(Sensor)	PVC	
Pin 1	Vhall 3-18 VDC	AWG26	black
Pin 2	Hall sensor HA	AWG26	black
Pin 3	Hall sensor HB	AWG26	black
Pin 4	Hall sensor HC	AWG26	black
Pin 5	GND	AWG26	black
Pin 6	Motor winding MA	AWG26	black
Pin 7	Motor winding MB	AWG26	black
Pin 8	Motor winding MC	AWG26	black
Connector			
JST	PHR-8		
Connection O	(Sensorless)		
Pin 1	Motor winding MA	AWG26	yellow
Pin 2	Motor winding MB	AWG26	green
Pin 3	Motor winding MC	AWG26	blue

## Drive combinations

Hall sensors	Encoder
SVTE-A-E40	SVTE-A-E45
SVTE-A-E50	SVTE-A-E55

## Encoder combinations

EN 22A  
EN 22AL

## Gearbox combinations

SVTG B 22  
SVTG B 24



ATOM EC Series  
SVTN A 01-2845

35 Watt

CORELESS  
BRUSHLESS

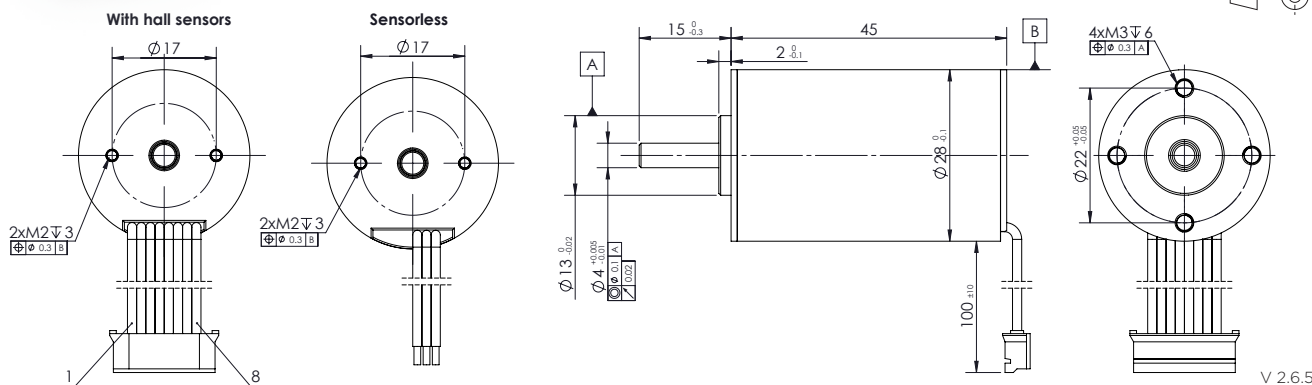

V 2.6.5

Values	Unit	SVTN A 01 2845-12..	2845-24..	2845-36..	2845-48..
--------	------	------------------------	-----------	-----------	-----------

Motor Data						
1	Nominal voltage	V	12	24	36	48
2	No load speed	rpm	13737	13756	13783	13400
3	No load current	mA	202	128	84	79
4	Nominal speed	rpm	12232	12342	12432	11903
5	Nominal torque	mNm	18	18	18	18
6	Nominal current	A	2,38	1,22	0,81	0,61
7	Stall torque	mNm	164	175	184	161
8	Stall current	A	20,1	10,8	7,53	4,87
9	Max. efficiency	%	81	79,4	80	76,1
Characteristics						
10	Terminal resistance*	Ω	0,6	2,23	4,78	9,86
11	Terminal inductance*	mH	0,08	0,34	0,73	1,47
12	Torque constant	mNm/A	8,26	16,5	24,7	33,7
13	Speed constant	rpm/V	1156	580	387	284
14	Speed/torque gradient	rpm/mNm	83,6	78,6	75	83,1
15	Mechanical time constant	ms	4,5	4,3	4,1	4,5
16	Rotor inertia	gcm <sup>2</sup>	5,2	5,2	5,2	5,2

Mechanical data		
17	Thermal resistance housing-ambient	9.6 K/W
18	Thermal resistance winding-housing	6.3 K/W
19	Thermal time constant winding	37 s
20	Thermal time constant motor	584 s
21	Ambient temperature	-30...+100°C
22	Max. permissible winding temperature	+150°C
23	Max. permissible speed	25000 rpm
24	Radial play	preloaded
25	Max. axial load (dynamic)	7.5 N
26	Max. force for press fits (static)	100 N
27	Max. radial loading, 5mm from flange	25 N
Other specifications		
28	Number of poles	2
29	Number of phases	3
30	Weight	120 g

\*The diagram based on ambient temperature of 25°.

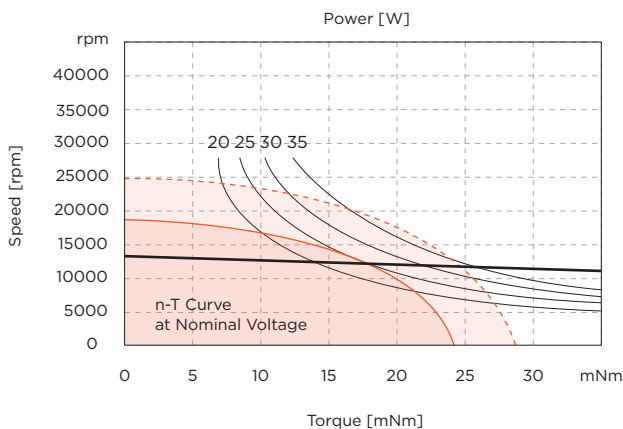

Continuous operating range  
Continuous operating range with Reduced Rη2 50%

Connection

Connection H (Sensor)			
Connection H	(Sensor)	PVC	
Pin 1	Vhall 3-18 VDC	AWG26	black
Pin 2	Hall sensor HA	AWG26	black
Pin 3	Hall sensor HB	AWG26	black
Pin 4	Hall sensor HC	AWG26	black
Pin 5	GND	AWG26	black
Pin 6	Motor winding MA	AWG26	black
Pin 7	Motor winding MB	AWG26	black
Pin 8	Motor winding MC	AWG26	black
Connector			
JST	PHR-8		
Connection O (Sensorless)			
Pin 1	Motor winding MA	AWG26	yellow
Pin 2	Motor winding MB	AWG26	green
Pin 3	Motor winding MC	AWG26	blue

Drive combinations

Hall sensors	Encoder
SVTE-A-E40	SVTE-A-E45
SVTE-A-E50	SVTE-A-E55

Encoder combinations

EN 22B  
EN 22BL

Gearbox combinations

SVTGB 28



# ATOM EC Series SVTN A 01-2854

72 Watt

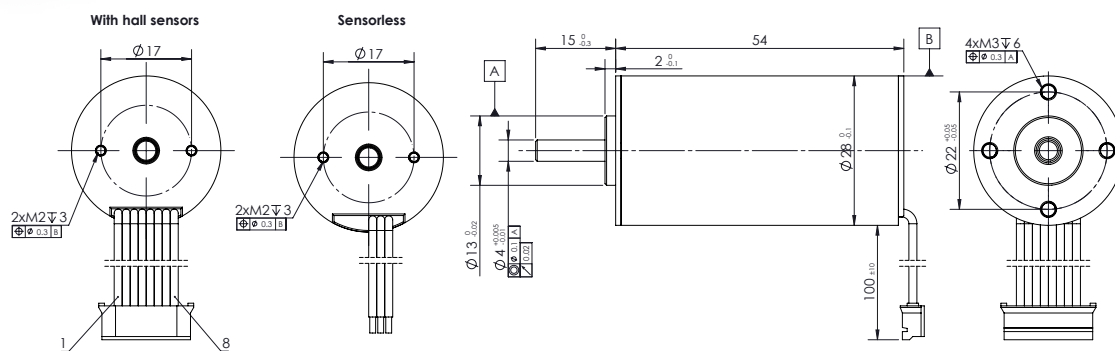

V 2.6.5

Values	Unit	SVTN A 01 2854-12..	2854-24..	2854-36..	2854-48..	
<b>Motor Data</b>						
1	Nominal voltage	V	12	24	36	48
2	No load speed	rpm	8031	8336	8175	8325
3	No load current	mA	142	94	65	51
4	Nominal speed	rpm	6646	7084	6891	6805
5	Nominal torque	mNm	35	35	35	35
6	Nominal current	A	2,62	1,38	0,91	0,7
7	Stall torque	mNm	203	233	223	192
8	Stall current	A	14,5	8,66	5,43	3,58
9	Max. efficiency	%	81,2	80,3	79,3	77,6
<b>Characteristics</b>						
10	Terminal resistance*	$\Omega$	0,83	2,77	6,63	13,4
11	Terminal inductance*	mH	0,16	0,61	1,41	2,56
12	Torque constant	mNm/A	14,1	27,2	41,5	54,3
13	Speed constant	rpm/V	676	351	230	176
14	Speed/torque gradient	rpm/mNm	39,6	35,8	36,7	43,4
15	Mechanical time constant	ms	3,5	3,2	3,3	3,9
16	Rotor inertia	gcm <sup>2</sup>	8,5	8,5	8,5	8,5
<b>Mechanical data</b>						
17	Thermal resistance housing-ambient	K/W	7,1			
18	Thermal resistance winding-housing	K/W	5			
19	Thermal time constant winding	s	51			
20	Thermal time constant motor	s	552			
21	Ambient temperature	°C	-30...+100			
22	Max. permissible winding temperature	°C	+150			
23	Max. permissible speed	rpm	25000			
24	Radial play		preloaded			
25	Max. axial load (dynamic)	N	7,5			
26	Max. force for press fits (static)	N	100			
27	Max. radial loading, 5mm from flange	N	25			
<b>Other specifications</b>						
28	Number of poles		2			
29	Number of phases		3			
30	Weight	g	156			

\*The diagram based on ambient temperature of 25°.

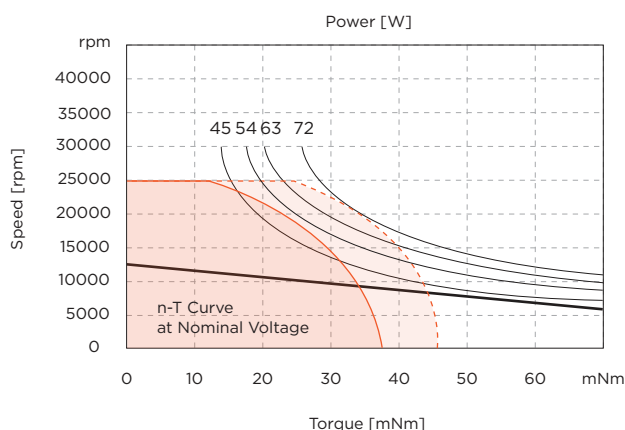

Continuous operating range  
Continuous operating range with Reduced Rth2 50%

## Connection

Connection H (Sensor)		PVC	
Pin 1	Vhall 3-18 VDC	AWG26	black
Pin 2	Hall sensor HA	AWG26	black
Pin 3	Hall sensor HB	AWG26	black
Pin 4	Hall sensor HC	AWG26	black
Pin 5	GND	AWG26	black
Pin 6	Motor winding MA	AWG26	black
Pin 7	Motor winding MB	AWG26	black
Pin 8	Motor winding MC	AWG26	black
Connector			
JST	PHR-8		
Connection O (Sensorless)			
Pin 1	Motor winding MA	AWG26	yellow
Pin 2	Motor winding MB	AWG26	green
Pin 3	Motor winding MC	AWG26	blue

## Drive combinations

Hall sensors	Encoder
SVTE-A-E40	SVTE-A-E45
SVTE-A-E50	SVTE-A-E55

## Encoder combinations

EN 22B  
EN 22BL

## Gearbox combinations

SVTG B 28



ATOM EC Series  
SVTN A 01-2864

CORELESS  
BRUSHLESS

With hall sensors

Sensorless

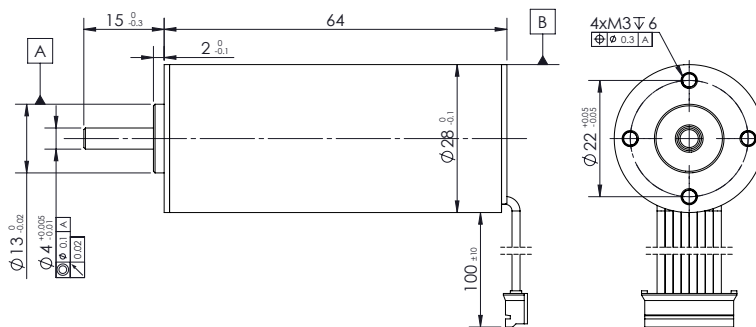
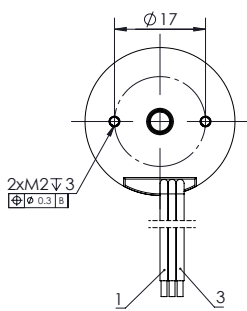
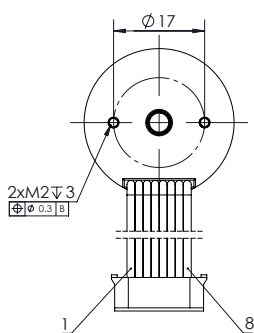

V 2.6.5

Values	Unit	SVTN A 01 2864-12..	2864-24..	2864-36..	2864-48..
--------	------	------------------------	-----------	-----------	-----------

Motor Data						
1	Nominal voltage	V	12	24	36	48
2	No load speed	rpm	7956	8014	8275	7960
3	No load current	mA	182	104	92	59
4	Nominal speed	rpm	6712	6840	7053	6782
5	Nominal torque	mNm	50	50	50	50
6	Nominal current	A	3,68	1,87	1,31	0,94
7	Stall torque	mNm	320	341	339	338
8	Stall current	A	22,6	12,1	8,33	5,99
9	Max. efficiency	%	82,8	82,3	80,1	81,1
Characteristics						
10	Terminal resistance*	Ω	0,53	1,98	4,32	8,02
11	Terminal inductance*	mH	0,11	0,46	0,96	1,83
12	Torque constant	mNm/A	14,3	14,3	14,3	14,3
13	Speed constant	rpm/V	668	337	232	167
14	Speed/torque gradient	rpm/mNm	24,9	23,5	24,4	23,6
15	Mechanical time constant	ms	2,5	2,4	2,5	2,4
16	Rotor inertia	gcm <sup>2</sup>	9,6	9,6	9,6	9,6

Mechanical data		
17	Thermal resistance housing-ambient	5.5 K/W
18	Thermal resistance winding-housing	4 K/W
19	Thermal time constant winding	56 s
20	Thermal time constant motor	521 s
21	Ambient temperature	-30...+100°C
22	Max. permissible winding temperature	+150°C
23	Max. permissible speed	25000 rpm
24	Radial play	preloaded
25	Max. axial load (dynamic)	7.5 N
26	Max. force for press fits (static)	100 N
27	Max. radial loading, 5mm from flange	25 N

Other specifications		
28	Number of poles	2
29	Number of phases	3
30	Weight	195 g

\*The diagram based on ambient temperature of 25°.

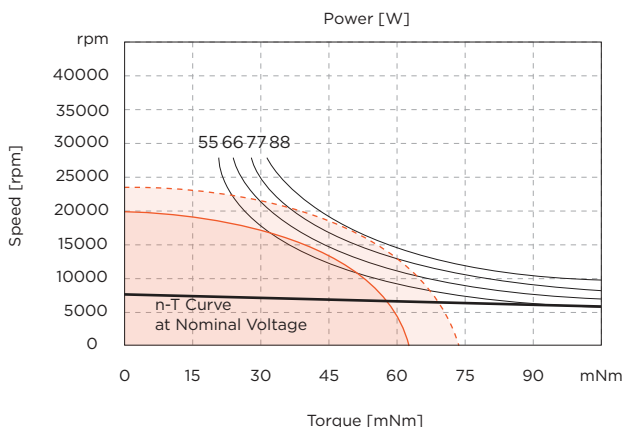

Continuous operating range  
Continuous operating range with Reduced Rtn2 50%

Connection

Connection H (Sensor)			
Connection H	(Sensor)	PVC	
Pin 1	Vhall 3-18 VDC	AWG26	black
Pin 2	Hall sensor HA	AWG26	black
Pin 3	Hall sensor HB	AWG26	black
Pin 4	Hall sensor HC	AWG26	black
Pin 5	GND	AWG26	black
Pin 6	Motor winding MA	AWG26	black
Pin 7	Motor winding MB	AWG26	black
Pin 8	Motor winding MC	AWG26	black
Connector	JST	PHR-8	
Connection O (Sensorless)			
Pin 1	Motor winding MA	AWG26	yellow
Pin 2	Motor winding MB	AWG26	green
Pin 3	Motor winding MC	AWG26	blue

Drive combinations

Hall sensors	Encoder
SVTE-A-E40	SVTE-A-E45
SVTE-A-E50	SVTE-A-E55

Encoder combinations

EN 22B  
EN 22BL

Gearbox combinations

SVTG B 28

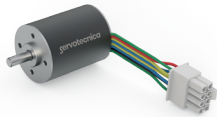

# ATOM EC Series SVTN A 01-3242

60 Watt

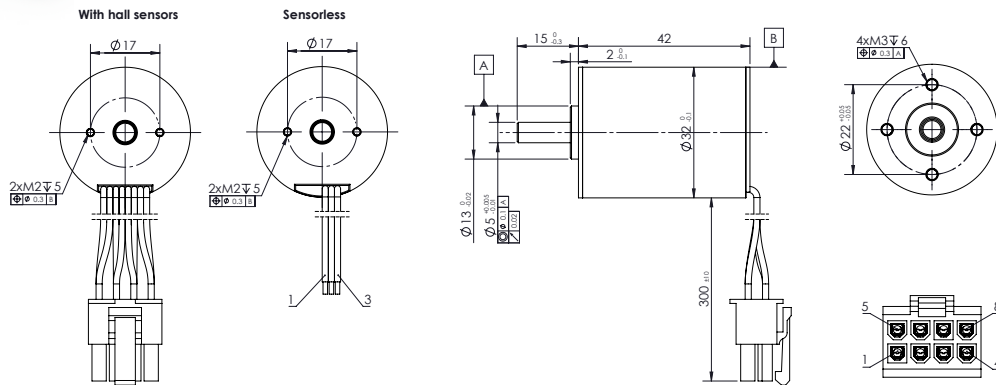
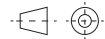

V 2.6.5

Values	Unit	SVTN A 01	3242-12..	3242-24..	3242-36..	3242-48..
<b>Motor Data</b>						
1	Nominal voltage	V	12	24	36	48
2	No load speed	rpm	9319	9516	9269	9389
3	No load current	mA	380	210	120	90
4	Nominal speed	rpm	8198	8364	8219	8124
5	Nominal torque	mNm	25	25	25	25
6	Nominal current	A	2,46	1,27	0,81	0,61
7	Stall torque	mNm	208	206	221	186
8	Stall current	A	17,6	8,99	6,19	3,98
9	Max. efficiency	%	72,8	71,8	74,1	72,2
<b>Characteristics</b>						
10	Terminal resistance*	$\Omega$	0,68	2,67	5,82	12,1
11	Terminal inductance*	mH	0,11	0,4	0,98	1,79
12	Torque constant	mNm/A	12	23,5	36,4	47,7
13	Speed constant	rpm/V	794	406	263	200
14	Speed/torque gradient	rpm/mNm	44,9	46,1	42	50,6
15	Mechanical time constant	ms	4,4	4,5	4,1	5
16	Rotor inertia	gcm <sup>2</sup>	9,4	9,4	9,4	9,4
<b>Mechanical data</b>						
17	Thermal resistance housing-ambient		8.8 K/W			
18	Thermal resistance winding-housing		2.7 K/W			
19	Thermal time constant winding		23.5 s			
20	Thermal time constant motor		560 s			
21	Ambient temperature		-30...+100°C			
22	Max. permissible winding temperature		+150°C			
23	Max. permissible speed		25000 rpm			
24	Radial play		preloaded			
25	Max. axial load (dynamic)		7.5 N			
26	Max. force for press fits (static)		100 N			
27	Max. radial loading, 5mm from flange		25 N			
<b>Other specifications</b>						
28	Number of poles		2			
29	Number of phases		3			
30	Weight		147 g			

\*The diagram based on ambient temperature of 25°.

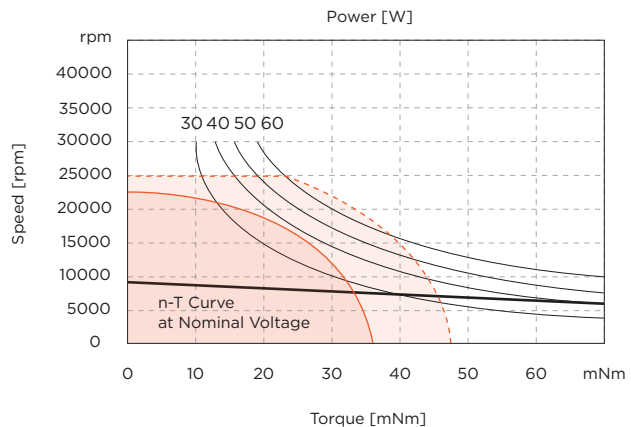

Continuous operating range  
Continuous operating range with Reduced Rtn2 50%

## Connection

Connection H	(Sensor)	PTFE
Pin 1	Motor winding MB	AWG20 green
Pin 2	Vhall 3-18 VDC	AWG26 red
Pin 3	Hall sensor HA	AWG26 yellow
Pin 4	Hall sensor HC	AWG26 blue
Pin 5	Motor winding MA	AWG20 yellow
Pin 6	Motor winding MC	AWG20 blue
Pin 7	GND	AWG26 black
Pin 8	Hall sensor HB	AWG26 green
Connector		
Molex	39-01-2080	
Connection O	(Sensorless)	PTFE
Pin 1	Motor winding MA	AWG20 yellow
Pin 2	Motor winding MB	AWG20 green
Pin 3	Motor winding MC	AWG20 blue

## Drive combinations

Hall sensors	Encoder
SVTE-A-E40	SVTE-A-E45
SVTE-A-E50	SVTE-A-E55

## Encoder combinations

EN 22B  
EN 22BL

## Gearbox combinations

SVTG B 32  
SVTG B 36

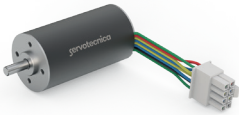

ATOM EC Series  
**SVTN A 01-3260**

120 Watt

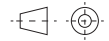

servotecnica  
CORELESS  
BRUSHLESS

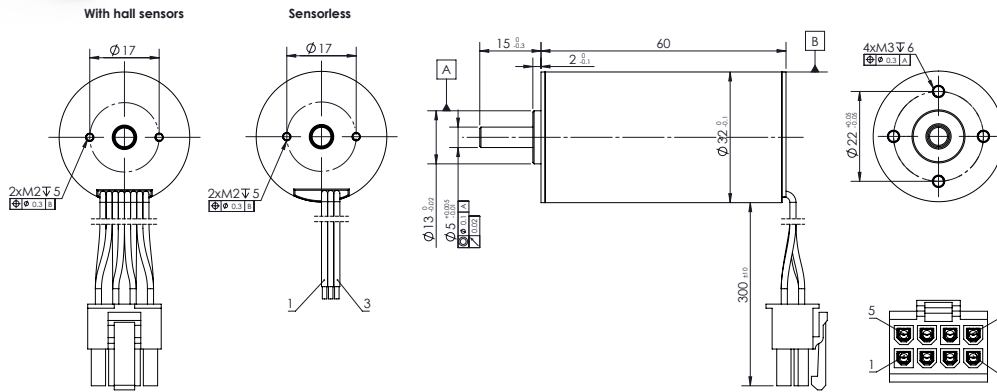

V 2.6.5

Values	Unit	SVTN A 01 3260-12..	3260-24..	3260-36..	3260-48..	
<b>Motor Data</b>						
1	Nominal voltage	V	12	24	36	48
2	No load speed	rpm	10845	11038	10937	11125
3	No load current	mA	430	190	130	90
4	Nominal speed	rpm	9889	10027	9931	10087
5	Nominal torque	mNm	50	50	50	50
6	Nominal current	A	5,2	2,62	1,73	1,31
7	Stall torque	mNm	567	546	544	536
8	Stall current	A	54,5	26,7	17,6	13,2
9	Max. efficiency	%	83	83,8	83,5	84,2
<b>Characteristics</b>						
10	Terminal resistance*	Ω	0,2	0,9	2,05	3,64
11	Terminal inductance*	mH	0,08	0,32	0,9	1,22
12	Torque constant	mNm/A	10,5	20,6	31,2	40,9
13	Speed constant	rpm/V	911	463	306	233
14	Speed/torque gradient	rpm/mNm	19,1	20,2	20,1	20,8
15	Mechanical time constant	ms	3,1	3,3	3,3	3,4
16	Rotor inertia	gcm <sup>2</sup>	15,5	15,5	15,5	15,5
<b>Mechanical data</b>						
17	Thermal resistance housing-ambient	K/W	6			
18	Thermal resistance winding-housing	K/W	3,2			
19	Thermal time constant winding	s	36			
20	Thermal time constant motor	s	626			
21	Ambient temperature	°C	-30...+100			
22	Max. permissible winding temperature	°C	+150			
23	Max. permissible speed	rpm	25000			
24	Radial play		preloaded			
25	Max. axial load (dynamic)	N	7,5			
26	Max. force for press fits (static)	N	100			
27	Max. radial loading, 5mm from flange	N	25			
<b>Other specifications</b>						
28	Number of poles		2			
29	Number of phases		3			
30	Weight	g	217			

\*The diagram based on ambient temperature of 25°.

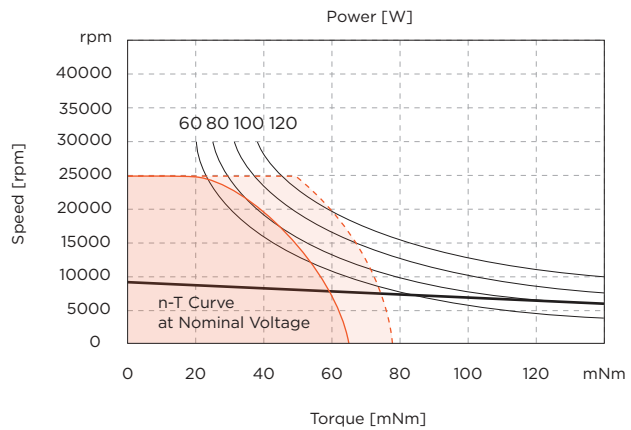

Continuous operating range  
Continuous operating range with Reduced Rη < 50%

**Connection**

Connection H (Sensor)		PTFE	
Pin 1	Motor winding MB	AWG20	green
Pin 2	Vhall 3-18 VDC	AWG26	red
Pin 3	Hall sensor HA	AWG26	yellow
Pin 4	Hall sensor HC	AWG26	blue
Pin 5	Motor winding MA	AWG20	yellow
Pin 6	Motor winding MC	AWG20	blue
Pin 7	GND	AWG26	black
Pin 8	Hall sensor HB	AWG26	green
Connector Molex 39-01-2080			
Connection O (Sensorless)		PTFE	
Pin 1	Motor winding MA	AWG20	yellow
Pin 2	Motor winding MB	AWG20	green
Pin 3	Motor winding MC	AWG20	blue

**Drive combinations**

Hall sensors	Encoder
SVTE-A-E40	SVTE-A-E45
SVTE-A-E50	SVTE-A-E55

**Encoder combinations**

EN 22B  
EN 22BL

**Gearbox combinations**

SVTG B 32  
SVTG B 36

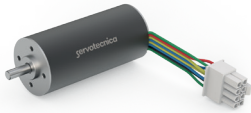

# ATOM EC Series SVTN A 01-3270

130 Watt

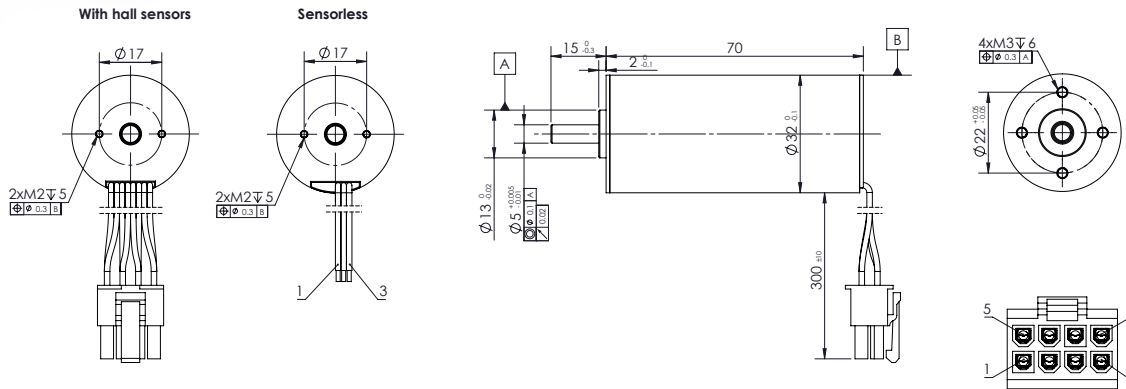
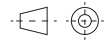

V 2.6.5

Values	Unit	SVTN A 01 3270-12..	3270-24..	3270-36..	3270-48..	
<b>Motor Data</b>						
1	Nominal voltage	V	12	24	36	48
2	No load speed	rpm	8998	9055	9252	9080
3	No load current	mA	450	180	100	90
4	Nominal speed	rpm	7991	7963	8129	8077
5	Nominal torque	mNm	70	70	70	70
6	Nominal current	A	6	2,97	2	1,49
7	Stall torque	mNm	625	581	577	634
8	Stall current	A	50	23,3	15,7	12,7
9	Max. efficiency	%	81,9	83,2	84,7	83,9
<b>Characteristics</b>						
10	Terminal resistance*	$\Omega$	0,24	1,03	2,29	3,77
11	Terminal inductance*	mH	0,09	0,35	0,75	1,33
12	Torque constant	mNm/A	12,6	25,1	36,9	50,1
13	Speed constant	rpm/V	757	380	259	191
14	Speed/torque gradient	rpm/mNm	14,4	15,6	16	14,3
15	Mechanical time constant	ms	2,8	3	3,1	2,8
16	Rotor inertia	gcm <sup>2</sup>	18,5	18,5	18,5	18,5
<b>Mechanical data</b>						
17	Thermal resistance housing-ambient	K/W	4,7			
18	Thermal resistance winding-housing	K/W	2,9			
19	Thermal time constant winding	s	38			
20	Thermal time constant motor	s	568			
21	Ambient temperature	°C	-30...+100			
22	Max. permissible winding temperature	°C	+150			
23	Max. permissible speed	rpm	25000			
24	Radial play		preloaded			
25	Max. axial load (dynamic)	N	7,5			
26	Max. force for press fits (static)	N	100			
27	Max. radial loading, 5mm from flange	N	25			
<b>Other specifications</b>						
28	Number of poles		2			
29	Number of phases		3			
30	Weight	g	256			

\*The diagram based on ambient temperature of 25°.

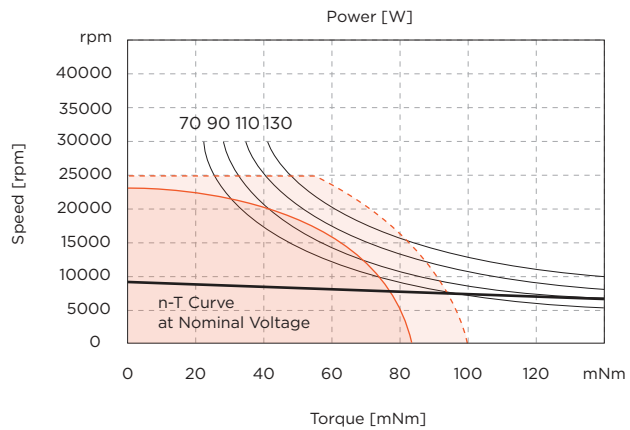

Continuous operating range  
Continuous operating range with Reduced Rtn 50%

## Connection

Connection H (Sensor)		PTFE	
Pin 1	Motor winding MB	AWG20	green
Pin 2	Vhall 3-18 VDC	AWG26	red
Pin 3	Hall sensor HA	AWG26	yellow
Pin 4	Hall sensor HC	AWG26	blue
Pin 5	Motor winding MA	AWG20	yellow
Pin 6	Motor winding MC	AWG20	blue
Pin 7	GND	AWG26	black
Pin 8	Hall sensor HB	AWG26	green
Connector			
Molex	39-01-2080		
Connection O (Sensorless)		PTFE	
Pin 1	Motor winding MA	AWG20	yellow
Pin 2	Motor winding MB	AWG20	green
Pin 3	Motor winding MC	AWG20	blue

## Drive combinations

Hall sensors	Encoder
SVTE-A-E40	SVTE-A-E45
SVTE-A-E50	SVTE-A-E55

## Encoder combinations

EN 22B  
EN 22BL

## Gearbox combinations

SVTG B 32  
SVTG B 36



ATOM EC Series  
**SVTN A 01-3660**

140 Watt

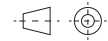

servotecnica  
CORELESS  
BRUSHLESS

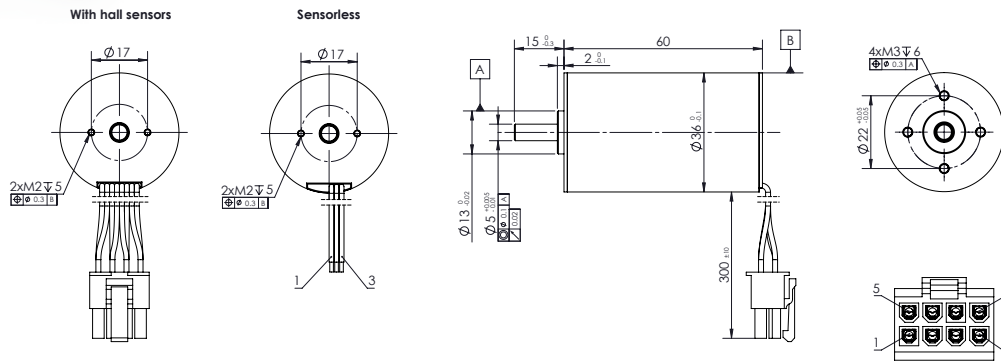

V 2.6.5

Values	Unit	SVTN A 01 3660-12..	3660-24..	3660-36..	3660-48..	
<b>Motor Data</b>						
1	Nominal voltage	V	12	24	36	48
2	No load speed	rpm	8050	8140	8014	8083
3	No load current	mA	288	148	101	84
4	Nominal speed	rpm	6794	6784	6804	6766
5	Nominal torque	mNm	82	82	82	82
6	Nominal current	A	6,09	3,08	2,03	1,54
7	Stall torque	mNm	526	492	543	503
8	Stall current	A	37,5	17,8	12,9	9,04
9	Max. efficiency	%	83,2	82,6	83,1	81,6
<b>Characteristics</b>						
10	Terminal resistance*	Ω	0,32	1,35	2,8	5,31
11	Terminal inductance*	mH	0,09	0,38	0,88	1,6
12	Torque constant	mNm/A	14,1	27,9	42,6	56,2
13	Speed constant	rpm/V	676	342	224	170
14	Speed/torque gradient	rpm/mNm	15,3	16,5	14,8	16,1
15	Mechanical time constant	ms	3,1	3,4	3	3,3
16	Rotor inertia	gcm <sup>2</sup>	19,5	19,5	19,5	19,5
<b>Mechanical data</b>						
17	Thermal resistance housing-ambient	K/W	4.4			
18	Thermal resistance winding-housing	K/W	1.3			
19	Thermal time constant winding	s	15			
20	Thermal time constant motor	s	582			
21	Ambient temperature	°C	-30...+100			
22	Max. permissible winding temperature	°C	+150			
23	Max. permissible speed	rpm	20000			
24	Radial play		preloaded			
25	Max. axial load (dynamic)	N	7.5			
26	Max. force for press fits (static)	N	100			
27	Max. radial loading, 5mm from flange	N	25			
<b>Other specifications</b>						
28	Number of poles		2			
29	Number of phases		3			
30	Weight	g	272			

\*The diagram based on ambient temperature of 25°.

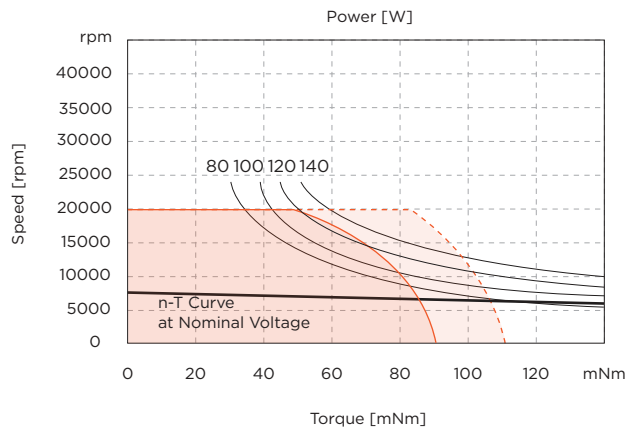

Continuous operating range  
Continuous operating range with Reduced Rtn2 50%

**Connection**

Connection H (Sensor)	PTFE	
Pin 1	Motor winding MB	AWG20 green
Pin 2	Vhall 3-18 VDC	AWG26 red
Pin 3	Hall sensor HA	AWG26 yellow
Pin 4	Hall sensor HC	AWG26 blue
Pin 5	Motor winding MA	AWG20 yellow
Pin 6	Motor winding MC	AWG20 blue
Pin 7	GND	AWG26 black
Pin 8	Hall sensor HB	AWG26 green
Connector		
Molex	39-01-2080	
Connection O (Sensorless)	PTFE	
Pin 1	Motor winding MA	AWG20 yellow
Pin 2	Motor winding MB	AWG20 green
Pin 3	Motor winding MC	AWG20 blue

**Drive combinations**

Hall sensors	Encoder
SVTE-A-E40	SVTE-A-E45
SVTE-A-E50	SVTE-A-E55

**Encoder combinations**

EN 22B  
EN 22BL

**Gearbox combinations**

SVTG B 36  
SVTG B 42



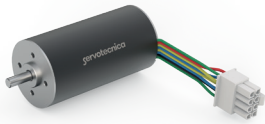

# ATOM EC Series SVTN A 01-3670

250 Watt

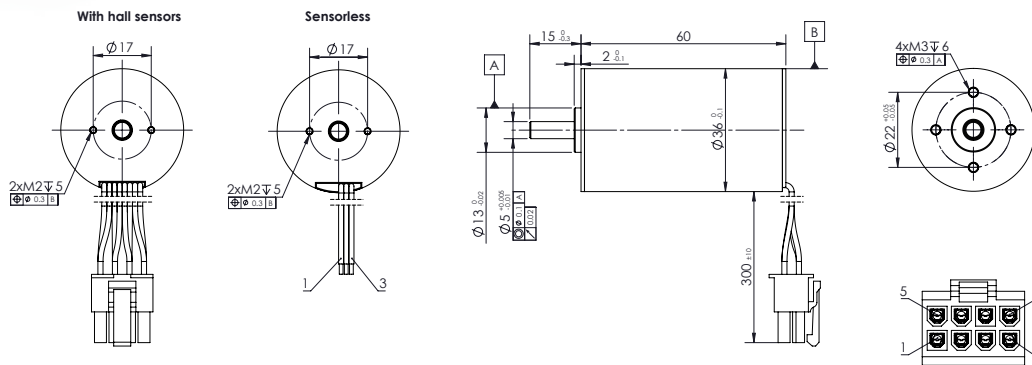

V 2.6.5

Values	Unit	SVTN A 01 3670-12..	3670-24..	3670-36..	3670-48..	
<b>Motor Data</b>						
1	Nominal voltage	V	12	24	36	48
2	No load speed	rpm	6578	6555	6675	6545
3	No load current	mA	293	137	101	78
4	Nominal speed	rpm	5300	5391	5455	5401
5	Nominal torque	mNm	120	120	120	120
6	Nominal current	A	7,24	3,59	2,45	1,81
7	Stall torque	mNm	618	676	657	687
8	Stall current	A	36	19,6	12,9	9,96
9	Max. efficiency	%	82,8	84	83,1	83,1
<b>Characteristics</b>						
10	Terminal resistance*	$\Omega$	0,33	1,22	2,78	4,82
11	Terminal inductance*	mH	0,09	0,38	0,85	1,52
12	Torque constant	mNm/A	17,3	34,7	51,1	69,5
13	Speed constant	rpm/V	553	275	187	137
14	Speed/torque gradient	rpm/mNm	10,7	9,7	10,2	9,5
15	Mechanical time constant	ms	2,4	2,2	2,3	2,1
16	Rotor inertia	gcm <sup>2</sup>	21,5	21,5	21,5	21,5
<b>Mechanical data</b>						
17	Thermal resistance housing-ambient	K/W	3,5			
18	Thermal resistance winding-housing	K/W	0,9			
19	Thermal time constant winding	s	14,3			
20	Thermal time constant motor	s	558			
21	Ambient temperature	°C	-30...+100			
22	Max. permissible winding temperature	°C	+150			
23	Max. permissible speed	rpm	20000			
24	Radial play		preloaded			
25	Max. axial load (dynamic)	N	7,5			
26	Max. force for press fits (static)	N	100			
27	Max. radial loading, 5mm from flange	N	25			
<b>Other specifications</b>						
28	Number of poles		2			
29	Number of phases		3			
30	Weight	g	331			

\*The diagram based on ambient temperature of 25°.

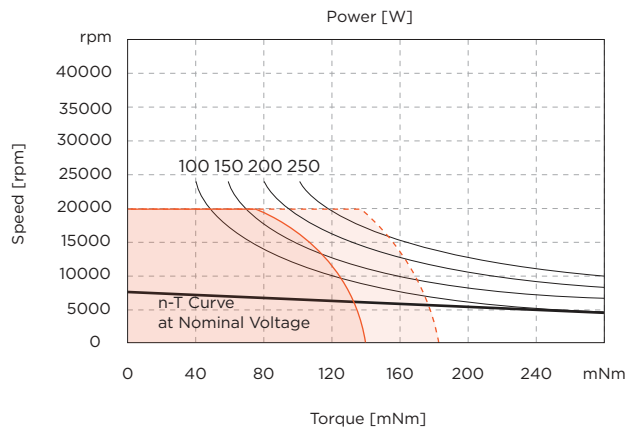

Continuous operating range  
Continuous operating range with Reduced  $R_{th2}$  50%

### Connection

Connection H (Sensor)	PTFE
Pin 1 Motor winding MB	AWG20 green
Pin 2 Vhall 3-18 VDC	AWG26 red
Pin 3 Hall sensor HA	AWG26 yellow
Pin 4 Hall sensor HC	AWG26 blue
Pin 5 Motor winding MA	AWG20 yellow
Pin 6 Motor winding MC	AWG20 blue
Pin 7 GND	AWG26 black
Pin 8 Hall sensor HB	AWG26 green
Connector Molex	39-01-2080
Connection O (Sensorless)	PTFE
Pin 1 Motor winding MA	AWG20 yellow
Pin 2 Motor winding MB	AWG20 green
Pin 3 Motor winding MC	AWG20 blue

### Drive combinations

Hall sensors	Encoder
SVTE-A-E40	SVTE-A-E45
SVTE-A-E50	SVTE-A-E55

### Encoder combinations

EN 22B  
EN 22BL

### Gearbox combinations

SVTG B 36  
SVTG B 42

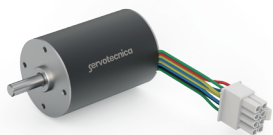

ATOM EC Series  
SVTN A 01-4058

150 Watt



servotecnica  
CORELESS  
BRUSHLESS

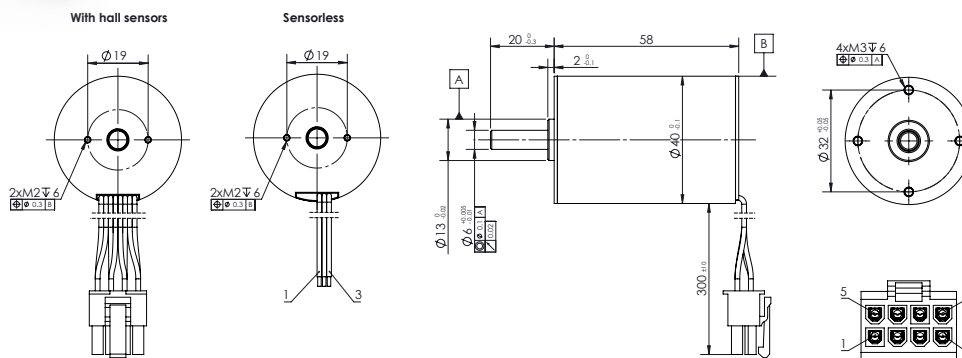

V 2.6.5

Values	Unit	SVTN A 01 4058-12..	4058-24..	4058-36..	4058-48..
--------	------	------------------------	-----------	-----------	-----------

Motor Data						
1	Nominal voltage	V	12	24	36	48
2	No load speed	rpm	7958	7890	7962	8001
3	No load current	mA	480	200	170	110
4	Nominal speed	rpm	7000	6912	6943	6986
5	Nominal torque	mNm	85	85	85	85
6	Nominal current	A	6,44	3,15	2,16	1,61
7	Stall torque	mNm	706	686	664	670
8	Stall current	A	50	24	15,7	11,9
9	Max. efficiency	%	81,4	82,6	80,3	81,7
Characteristics						
10	Terminal resistance*	Ω	0,24	1	2,29	4,03
11	Terminal inductance*	mH	0,11	0,46	0,97	1,67
12	Torque constant	mNm/A	14,3	28,8	42,7	56,8
13	Speed constant	rpm/V	670	332	224	168
14	Speed/torque gradient	rpm/mNm	11,3	11,5	12	11,9
15	Mechanical time constant	ms	3,5	3,6	3,7	3,7
16	Rotor inertia	gcm <sup>2</sup>	29,6	29,6	29,6	29,6

Mechanical data		
17	Thermal resistance housing-ambient	4.7 K/W
18	Thermal resistance winding-housing	2.2 K/W
19	Thermal time constant winding	35 s
20	Thermal time constant motor	777 s
21	Ambient temperature	-30...+100°C
22	Max. permissible winding temperature	+150°C
23	Max. permissible speed	17500 rpm
24	Radial play	preloaded
25	Max. axial load (dynamic)	9 N
26	Max. force for press fits (static)	170 N
27	Max. radial loading, 5mm from flange	80 N

Other specifications		
28	Number of poles	2
29	Number of phases	3
30	Weight	338 g

\*The diagram based on ambient temperature of 25°.

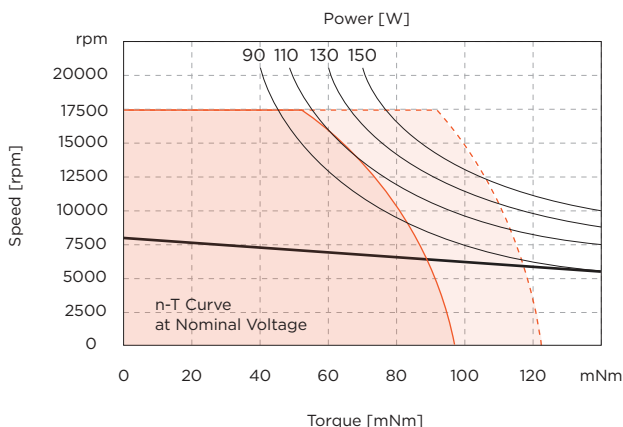

Continuous operating range  
Continuous operating range with Reduced Rtn2 50%

Connection

Connection H (Sensor)			
Connection H	(Sensor)	PTFE	
Pin 1	Motor winding MB	AWG20	green
Pin 2	Vhall 3-18 VDC	AWG26	red
Pin 3	Hall sensor HA	AWG26	yellow
Pin 4	Hall sensor HC	AWG26	blue
Pin 5	Motor winding MA	AWG20	yellow
Pin 6	Motor winding MC	AWG20	blue
Pin 7	GND	AWG26	black
Pin 8	Hall sensor HB	AWG26	green
Connector			
Molex	39-01-2080		
Connection O (Sensorless)			
Connection O	(Sensorless)	PTFE	
Pin 1	Motor winding MA	AWG20	yellow
Pin 2	Motor winding MB	AWG20	green
Pin 3	Motor winding MC	AWG20	blue

Drive combinations

Hall sensors	Encoder
SVTE-A-E40	SVTE-A-E45
SVTE-A-E50	SVTE-A-E55

Encoder combinations

EN 24B  
EN 24BL

Gearbox combinations

SVTG B 42

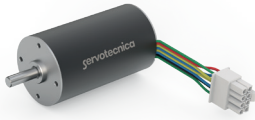

# ATOM EC Series SVTN A 01-4070

210 Watt

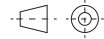
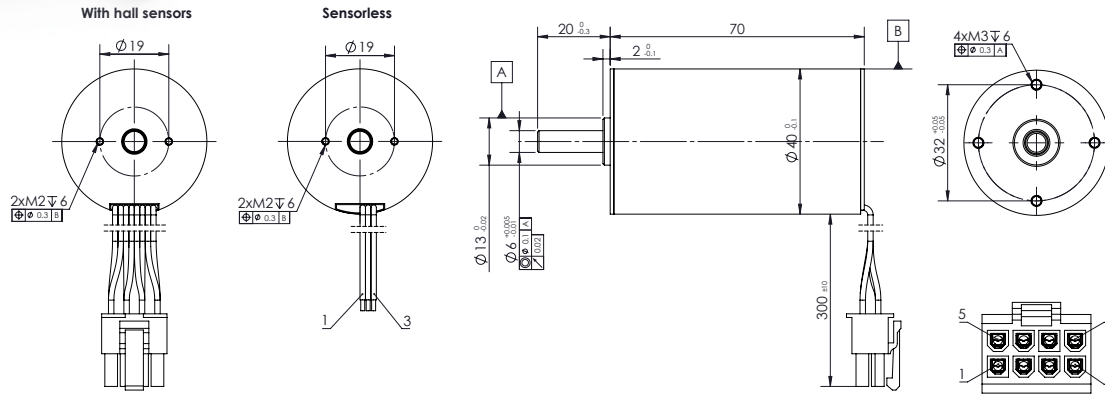

V 2.6.5

Values	Unit	SVTN A 01 4070-12..	4070-24..	4070-36..	4070-48..	
<b>Motor Data</b>						
1	Nominal voltage	V	12	24	36	48
2	No load speed	rpm	6154	8102	8113	8061
3	No load current	mA	264	200	190	130
4	Nominal speed	rpm	5084	7304	7266	7238
5	Nominal torque	mNm	130	130	130	130
6	Nominal current	A	7,29	4,82	3,28	2,43
7	Stall torque	mNm	748	1320	1245	1273
8	Stall current	A	40,7	47,1	29,8	22,6
9	Max. efficiency	%	84,5	87,4	84,7	85,4
<b>Characteristics</b>						
10	Terminal resistance*	Ω	0,3	0,51	1,21	2,12
11	Terminal inductance*	mH	0,11	0,3	0,66	1,2
12	Torque constant	mNm/A	18,5	28,2	42,1	56,5
13	Speed constant	rpm/V	516	339	227	169
14	Speed/torque gradient	rpm/mNm	8,23	6,14	6,52	6,33
15	Mechanical time constant	ms	3,4	2,5	2,7	2,6
16	Rotor inertia	gcm <sup>2</sup>	39,4	39,4	39,4	39,4
<b>Mechanical data</b>						
17	Thermal resistance housing-ambient	K/W	3,8			
18	Thermal resistance winding-housing	K/W	1,5			
19	Thermal time constant winding	s	33			
20	Thermal time constant motor	s	775			
21	Ambient temperature	°C	-30...+100			
22	Max. permissible winding temperature	°C	+150			
23	Max. permissible speed	rpm	17500			
24	Radial play		preloaded			
25	Max. axial load (dynamic)	N	9			
26	Max. force for press fits (static)	N	170			
27	Max. radial loading, 5mm from flange	N	80			
<b>Other specifications</b>						
28	Number of poles		2			
29	Number of phases		3			
30	Weight	g	415			

\*The diagram based on ambient temperature of 25°.

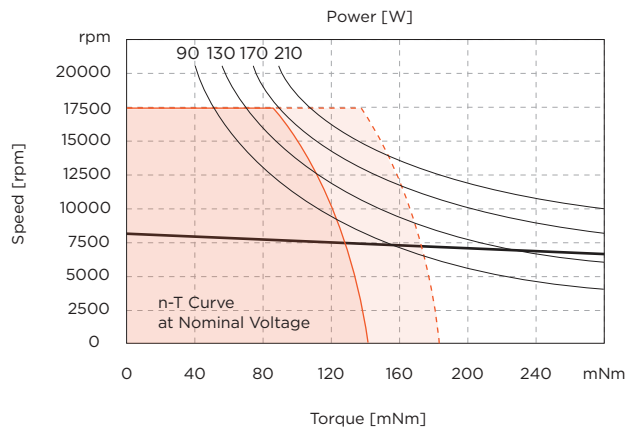

Continuous operating range  
Continuous operating range with Reduced Rth2 50%

## Connection

Connection H	(Sensor)	PTFE
Pin 1	Motor winding MB	AWG20 green
Pin 2	Vhall 3-18 VDC	AWG26 red
Pin 3	Hall sensor HA	AWG26 yellow
Pin 4	Hall sensor HC	AWG26 blue
Pin 5	Motor winding MA	AWG20 yellow
Pin 6	Motor winding MC	AWG20 blue
Pin 7	GND	AWG26 black
Pin 8	Hall sensor HB	AWG26 green
Connector		
Molex	39-01-2080	
Connection O	(Sensorless)	PTFE
Pin 1	Motor winding MA	AWG20 yellow
Pin 2	Motor winding MB	AWG20 green
Pin 3	Motor winding MC	AWG20 blue

## Drive combinations

Hall sensors	Encoder
SVTE-A-E40	SVTE-A-E45
SVTE-A-E50	SVTE-A-E55

## Encoder combinations

EN 24B  
EN 24BL

## Gearbox combinations

SVTG B 42

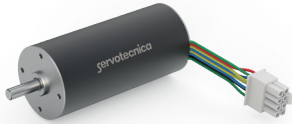

ATOM EC Series  
**SVTN A 01-4088**

400 Watt

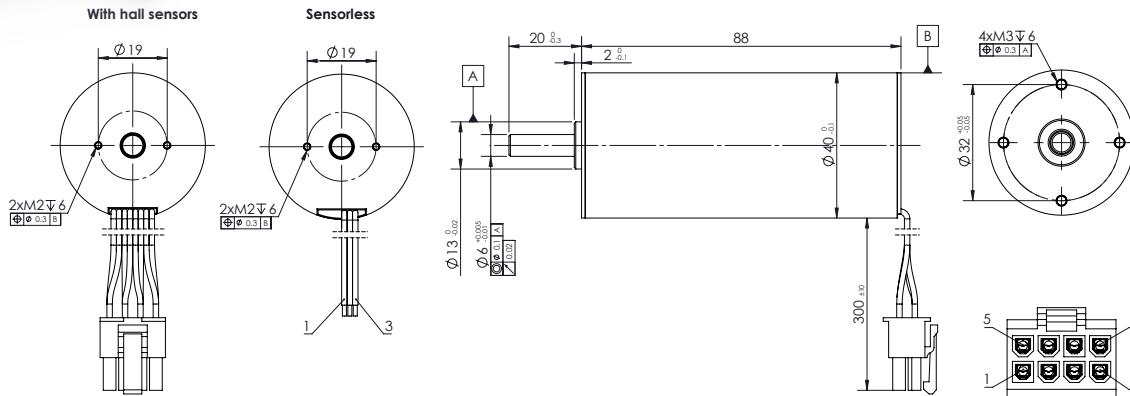

V 2.6.5

Values	Unit	SVTN A 01 4088-24..	4088-36..	4088-48..
--------	------	------------------------	-----------	-----------

Motor Data					
1	Nominal voltage	V	24	36	48
2	No load speed	rpm	7921	8032	8081
3	No load current	mA	440	290	200
4	Nominal speed	rpm	7299	7379	7452
5	Nominal torque	mNm	200	200	200
6	Nominal current	A	7,39	4,99	3,74
7	Stall torque	mNm	2546	2460	2570
8	Stall current	A	88,9	58,1	45,7
9	Max. efficiency	%	86,4	86,4	87,2
Characteristics					
10	Terminal resistance*	Ω	0,27	0,62	1,05
11	Terminal inductance*	mH	0,18	0,38	0,78
12	Torque constant	mNm/A	28,8	42,6	56,5
13	Speed constant	rpm/V	332	224	169
14	Speed/torque gradient	rpm/mNm	3,1	3,3	3,1
15	Mechanical time constant	ms	1,8	1,9	1,8
16	Rotor inertia	gcm <sup>2</sup>	54,1	54,1	54,1

Mechanical data		
17	Thermal resistance housing-ambient	3.0 K/W
18	Thermal resistance winding-housing	0.6 K/W
19	Thermal time constant winding	48 s
20	Thermal time constant motor	996 s
21	Ambient temperature	-30...+100°C
22	Max. permissible winding temperature	+150°C
23	Max. permissible speed	17500 rpm
24	Radial play	preloaded
25	Max. axial load (dynamic)	9 N
26	Max. force for press fits (static)	170 N
27	Max. radial loading, 5mm from flange	80 N
Other specifications		
28	Number of poles	2
29	Number of phases	3
30	Weight	571 g

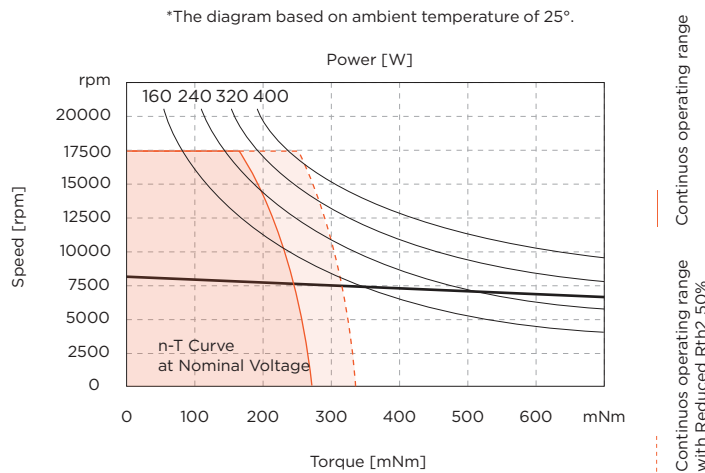

Connection

Connection H (Sensor)		PTFE
Pin 1	Motor winding MB	AWG20 green
Pin 2	Vhall 3-18 VDC	AWG26 red
Pin 3	Hall sensor HA	AWG26 yellow
Pin 4	Hall sensor HC	AWG26 blue
Pin 5	Motor winding MA	AWG20 yellow
Pin 6	Motor winding MC	AWG20 blue
Pin 7	GND	AWG26 black
Pin 8	Hall sensor HB	AWG26 green
Connector	Molex 39-01-2080	
Connection O (Sensorless)		PTFE
Pin 1	Motor winding MA	AWG20 yellow
Pin 2	Motor winding MB	AWG20 green
Pin 3	Motor winding MC	AWG20 blue

Drive combinations

Hall sensors	Encoder
SVTE-A-E40	SVTE-A-E45
SVTE-A-E50	SVTE-A-E55

Encoder combinations

- EN 24B
- EN 24BL

Gearbox combinations

- SVTG B 42

Hello,  
how can I help you?



TDS Precision Products GmbH  
Industriestrasse 1a  
CH-8157 Dielsdorf

T + 41 44 885 30 80  
info@tds-pp.com  
www.tds-pp.com