



GEEPLUS

VM1614

P_{100} is the continuous (100% ED) excitation power at which the coil attains temperature T_{max} with the part mounted to a massive heatsink at 20°C

P_{100} 5 W
 T_{max} 130 °C

Total Mass 15 g
 Coil Mass 3 g

Model No.	Resistance R_{20}	Inductance	Force Constant	Velocity Constant	Current I_{100}
VM1614-200	2.6 Ω	0.2mH	0.7 N/A	0.7 Vs/m	1172 mA
VM1614-180	3.5 Ω	0.3mH	0.8 N/A	0.8 Vs/m	1010 mA
VM1614-125	15.0 Ω	0.8mH	1.5 N/A	1.5 Vs/m	488 mA
VM1614-100	39.0 Ω	4.0mH	2.4 N/A	2.4 Vs/m	303 mA

Max 'ON' time		
100% ED	∞	0.8 N
50% ED	22 s	1.1 N
25% ED	9 s	1.7 N
10% ED	3 s	2.3 N

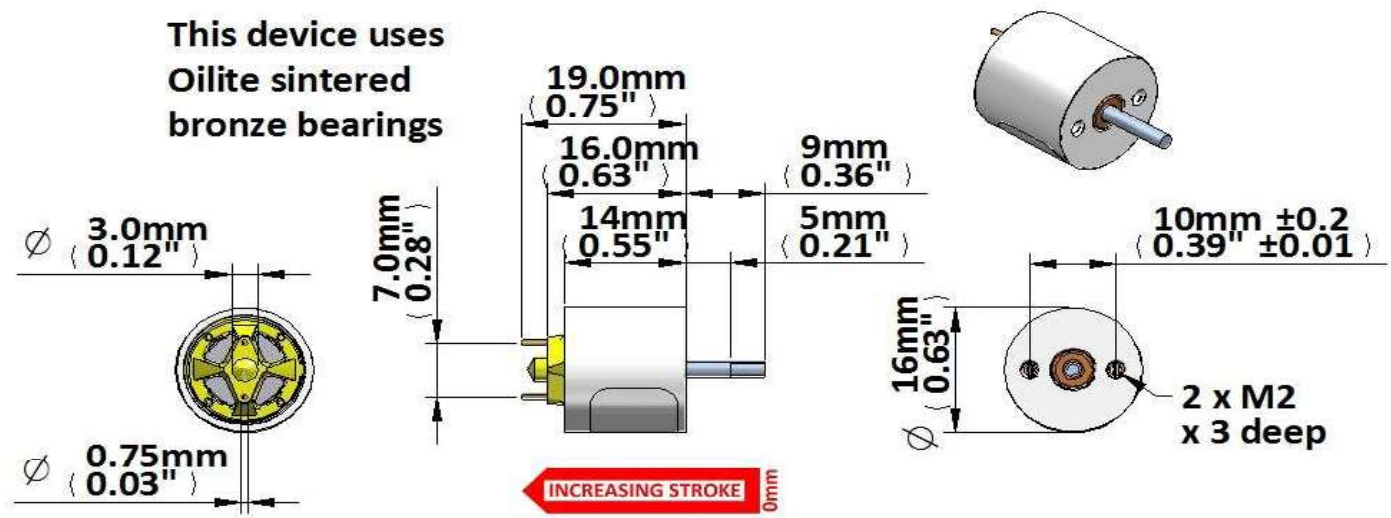

Force (N) vs Displacement (mm)

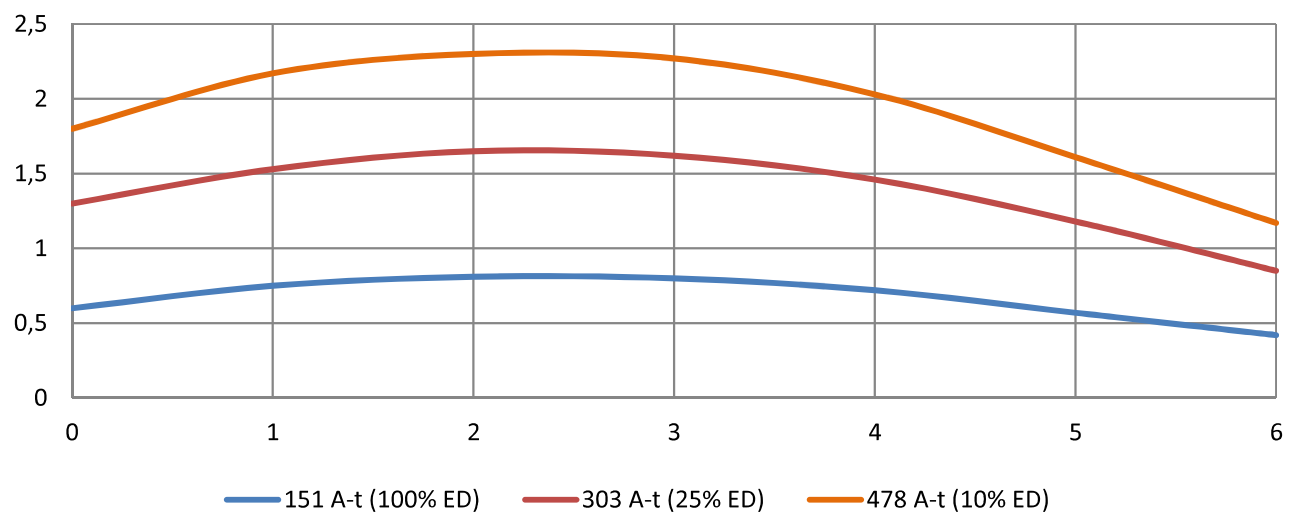

Geeplus reserves the right to change specifications without notice
www.geeplus.com