



TDS Precision Products
 TDS Precision Products GmbH
 Industriestrasse 1a
 CH-8157 Dielsdorf
 T + 41 44 885 30 80
 info@tds-pp.com
 www.tds-pp.com



AVM Series



Direct drive,
zero cogging,
zero backlash
voice coil motors



Low coil mass with
very fast response
and bandwidth



No contact between
coil and core movement
(no wear and tear)



Smooth motion at
low speeds with
limitless resolution
(depends on
feedback device)

(Standard Series) AVM

Specifications

Model	Units	AVM 12-6.4	AVM 19-5	AVM 20-10	AVM 24-5	AVM 24-10
Stroke	mm	6.4	5	10	5	10
Force sensitivity (at mid stroke)	N/A	0.57	1.75	2.00	3.00	3.90
Back EMF constant	V/(m/s)	0.57	1.75	2.00	3.00	3.90
Continuous force (at 100 °C) ^①	N	0.91	1.75	1.56	2.10	2.65
Peak force	N	3.53	7.88	7.60	11.40	14.82
Resistance ^②	ohms	1.13	2.23	3.59	3.09	5.86
Inductance ^②	mH	0.09	0.27	0.50	0.51	1.23
Voltage at peak force	V	7.01	10.04	13.64	11.7	22.3
Continuous current (coil at 100 °C)	A	1.60	1.00	0.78	0.70	0.68
Peak current	A	6.20	4.50	3.80	3.80	3.80
Max voltage	Vdc	60	60	60	60	60
Actuator constant	N/Sqrt(W)	0.54	1.17	1.06	1.71	1.61
Continuous power	W	2.89	2.23	2.18	1.51	2.71
Electrical time constant	ms	0.08	0.12	0.14	0.17	0.21
Mechanical time constant	ms	17.39	6.55	9.87	4.12	6.36
Clearance of coil	mm	0.35	0.40	0.50	0.50	0.50
Power at peak force	W	43.44	45.16	51.84	44.62	84.62
Thermal dissipation constant	W/°C	0.039	0.030	0.029	0.020	0.036
Max coil temperature	°C	100	100	100	100	100
Coil assembly mass	g	5.0	9.0	11.0	12.0	16.5
Core assembly mass	g	7.3	23.8	45.1	29.7	45.0

Model	Units	AVM 30-15	AVM 40-20	AVM 60-25	AVM 90-30
Stroke	mm	15	20	25	30
Force sensitivity (at mid stroke)	N/A	7.35	12.90	17.00	22.50
Back EMF constant	V/(m/s)	7.35	12.90	17.00	22.50
Continuous force (at 100 °C) ^①	N	4.63	9.93	26.35	89.10
Peak force	N	29.40	58.05	119.00	315.00
Resistance ^②	ohms	10.22	12.10	5.37	2.70
Inductance ^②	mH	2.63	5.12	3.73	3.20
Voltage at peak force	V	40.88	54.45	37.59	37.8
Continuous current (coil at 100 °C)	A	0.63	0.77	1.55	3.96
Peak current	A	4.00	4.50	7.00	14.00
Max voltage	Vdc	60	60	60	120
Actuator constant	N/Sqrt(W)	2.30	3.71	7.34	13.69
Continuous power	W	4.06	7.17	12.90	42.34
Electrical time constant	ms	0.26	0.42	0.69	1.19
Mechanical time constant	ms	6.81	4.87	3.99	4.37
Clearance of coil	mm	0.60	0.60	0.70	0.65
Power at peak force	W	163.52	245.03	263.13	529.20
Thermal dissipation constant	W/°C	0.054	0.096	0.172	0.565
Max coil temperature	°C	100	100	100	100
Coil assembly mass	g	36.0	67.0	215.0	820.0
Core assembly mass	g	95.6	226.2	692.9	1750.0

^① Continuous force measured without any additional mounting plate or heat sink on coil

^② Measured at 25 °C

(Standard Series) AVM

■ Dimensions

■ AVM 12-6.4

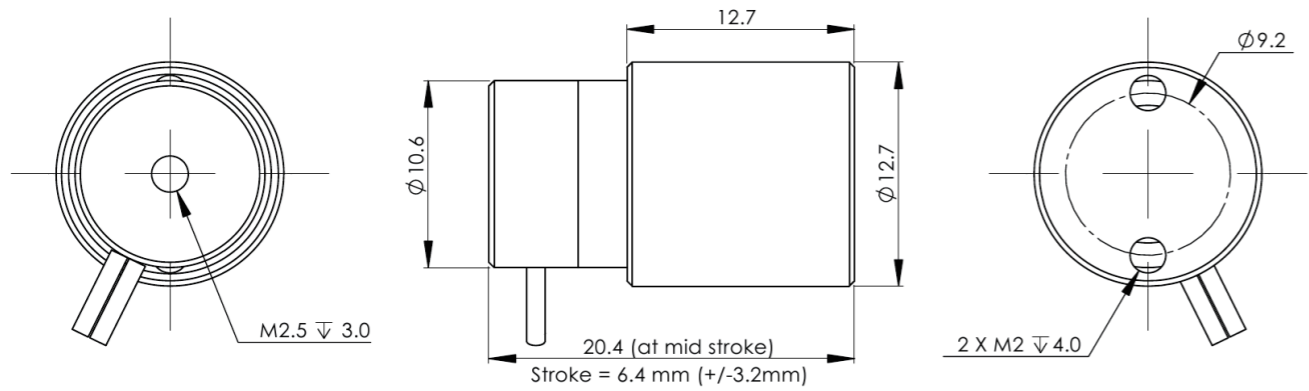

■ AVM 19-5

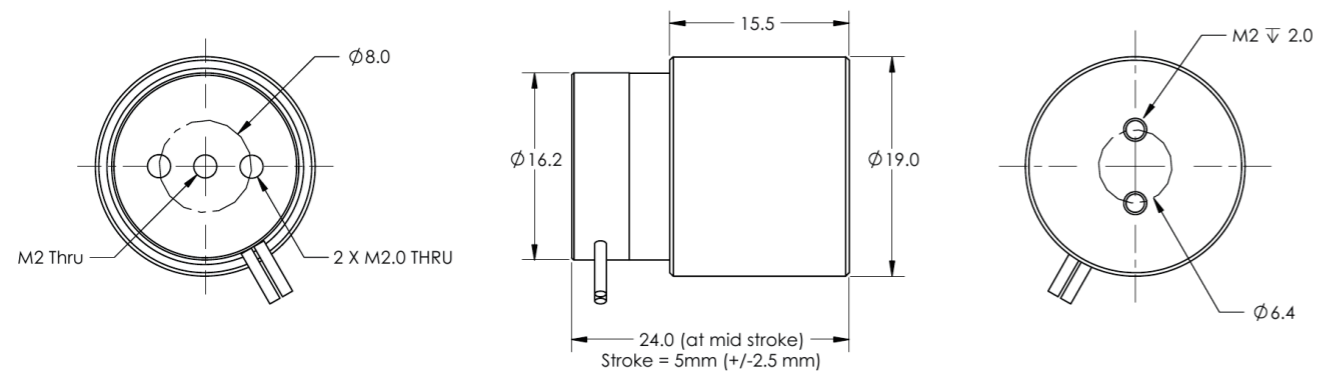

■ AVM 20-10

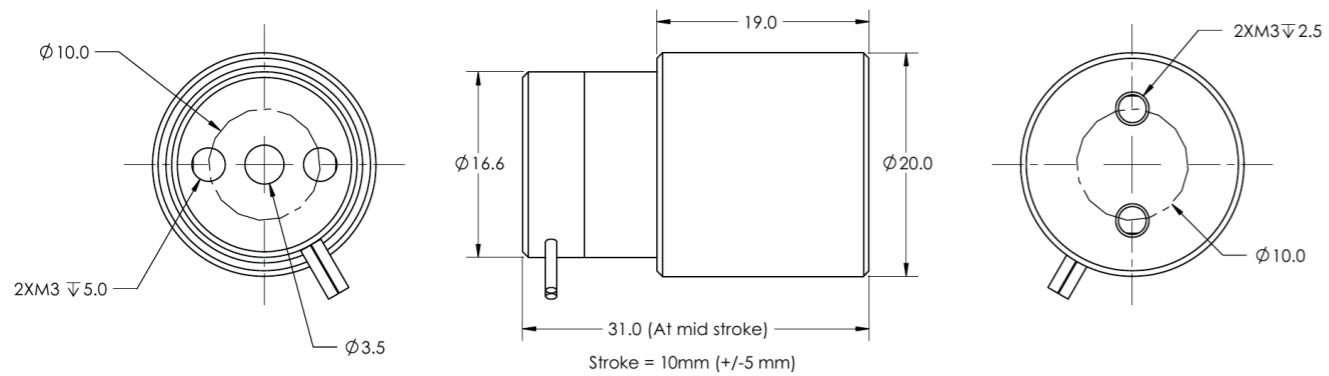

(Standard Series) AVM

■ Dimensions

■ AVM 24-5

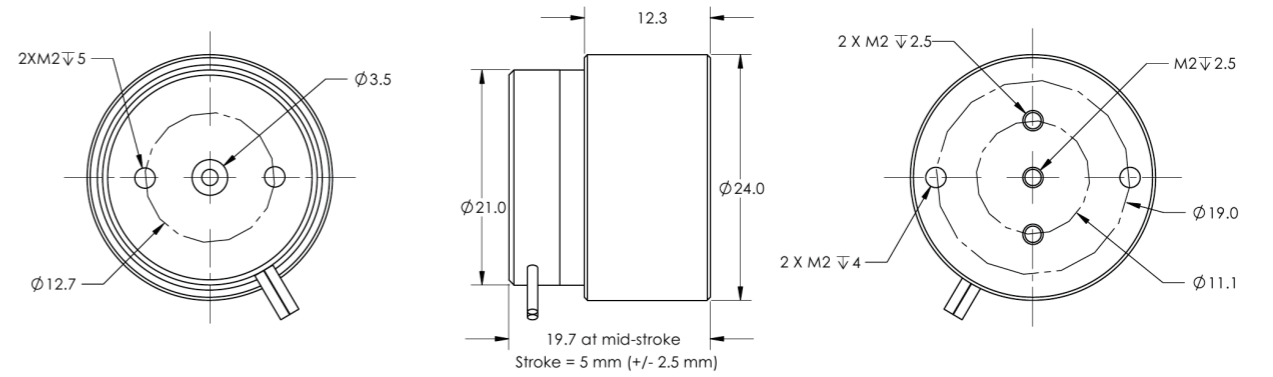

■ AVM 24-10

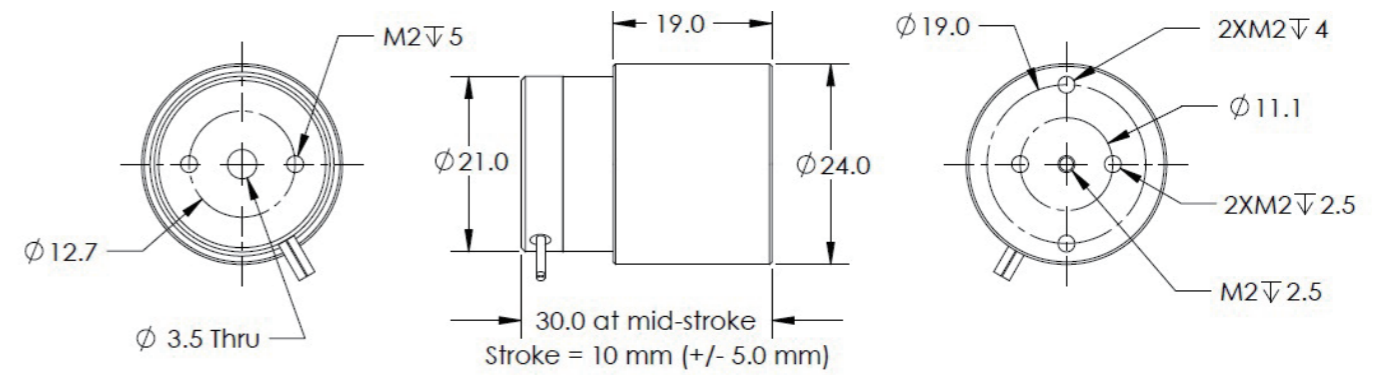

■ AVM 30-15

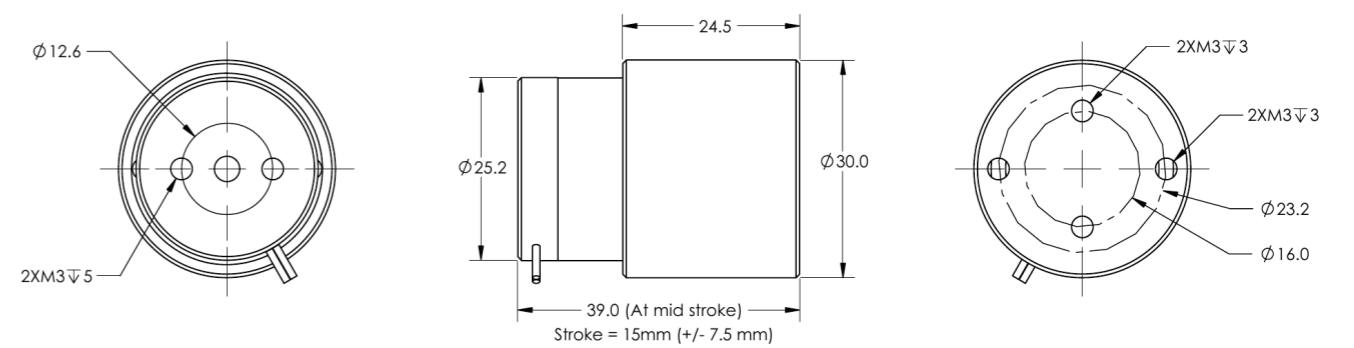

Dimensions

(Standard Series) AVM

AVM 40-20

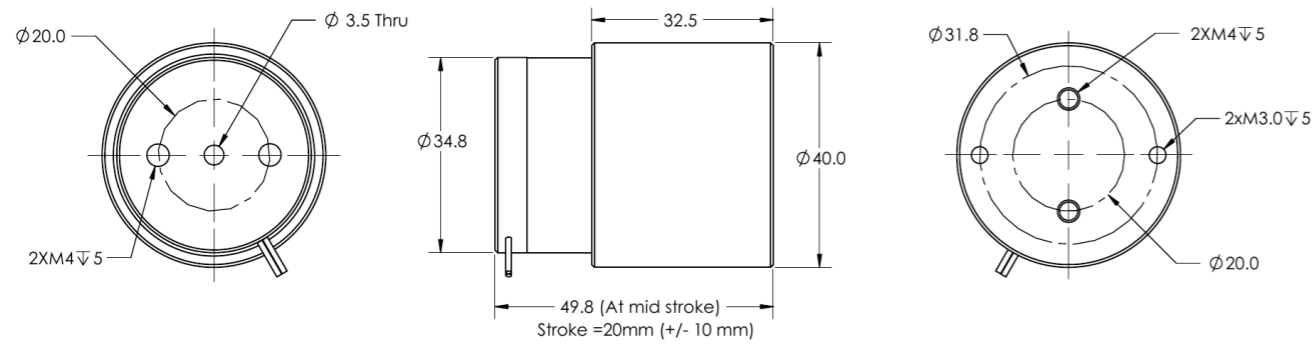

AVM 60-25

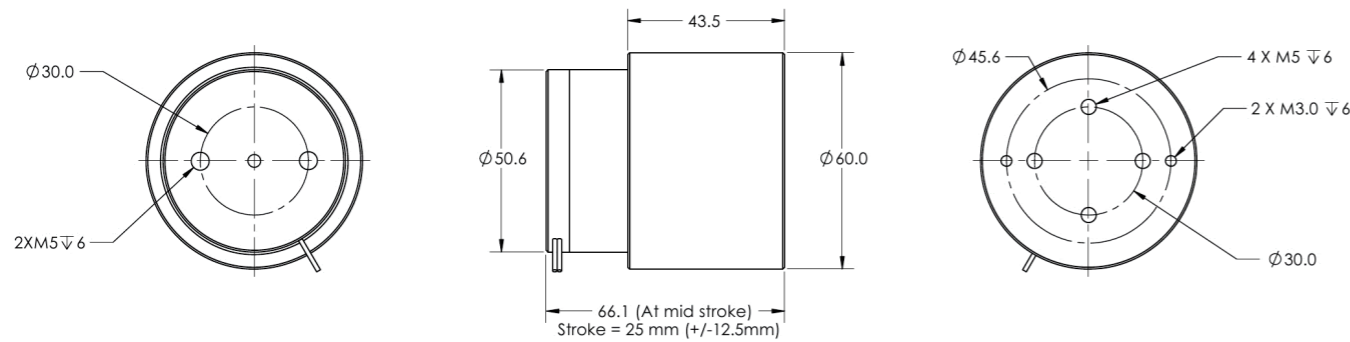

AVM 90-30

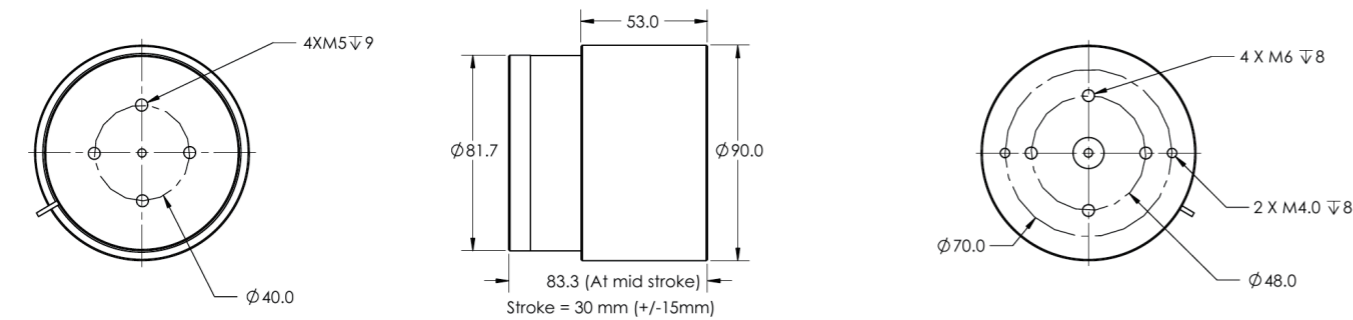

Specifications

(High Force Series) AVM

Model	Units	AVM 35-HF-7	AVM 40-HF-6.5	AVM 50-HF-10	AVM 60-HF-10
Stroke	mm	7	6.5	10	10
Force sensitivity (at mid stroke)	N/A	16.00	20.70	28.00	32.00
Back EMF constant	V/(m/s)	16.00	20.70	28.00	32.00
Continuous force (at 100 °C) ^①	N	14.40	16.56	33.60	51.20
Peak force	N	72.00	93.15	140.00	224.00
Resistance ^②	ohms	9.80	11.31	8.64	5.91
Inductance ^②	mH	3.60	4.47	5.30	4.01
Voltage at peak force	V	44.10	50.90	43.20	41.4
Continuous current (coil at 100 °C)	A	0.90	0.80	1.20	1.60
Peak current	A	4.50	4.50	5.00	7.00
Max voltage	Vdc	60	60	60	60
Actuator constant	N/Sqrt(W)	5.11	6.16	9.53	13.16
Continuous power	W	7.14	7.24	12.44	15.13
Electrical time constant	ms	0.37	0.40	0.61	0.68
Mechanical time constant	ms	2.03	1.79	1.63	1.36
Clearance of coil	mm	0.50	0.60	0.60	0.70
Power at peak force	W	198.45	229.03	216.00	289.59
Thermal dissipation constant	W/°C	0.095	0.097	0.166	0.202
Max coil temperature	°C	100	100	100	100
Coil assembly mass	g	53.0	68.0	148.0	236.5
Core assembly mass	g	146.8	218.7	553.0	997.0

Model	Units	AVM 90-HF-10	AVM 100-HF-10	AVM 130-HF-25	AVM 250-HF-20
Stroke	mm	10	10	25	20
Force sensitivity (at mid stroke)	N/A	43.62	55.00	54.60	168.40
Back EMF constant	V/(m/s)	43.62	55.00	54.60	168.40
Continuous force (at 100 °C) ^①	N	152.67	192.50	360.36	1111.44
Peak force	N	610.68	770.00	764.40	4715.20
Resistance ^②	ohms	2.90	3.20	1.48	3.70
Inductance ^②	mH	3.59	4.12	1.70	5.00
Voltage at peak force	V	40.60	44.80	20.72	103.6
Continuous current (coil at 100 °C)	A	3.50	3.50	6.60	6.60
Peak current	A	14.00	14.00	14.00	28.00
Max voltage	Vdc	120	120	120	120
Actuator constant	N/Sqrt(W)	25.61	30.75	44.88	87.55
Continuous power	W	35.53	39.20	64.47	161.17
Electrical time constant	ms	1.24	1.29	1.15	1.35
Mechanical time constant	ms	1.46	1.18	0.77	0.77
Clearance of coil	mm	0.65	0.65	0.55	0.90
Power at peak force	W	568.40	627.20	290.08	2900.80
Thermal dissipation constant	W/°C	0.474	0.523	0.860	2.149
Max coil temperature	°C	100	100	100	100
Coil assembly mass	g	960.0	1117.0	1550.0	5900.0
Core assembly mass	g	2400.0	3300.0	9300.0	27200.0

① Continuous force measured without any additional mounting plate or heat sink on coil

② Measured at 25 °C

Dimensions

(High Force Serie) **AVM**

AVM 35-HF-7

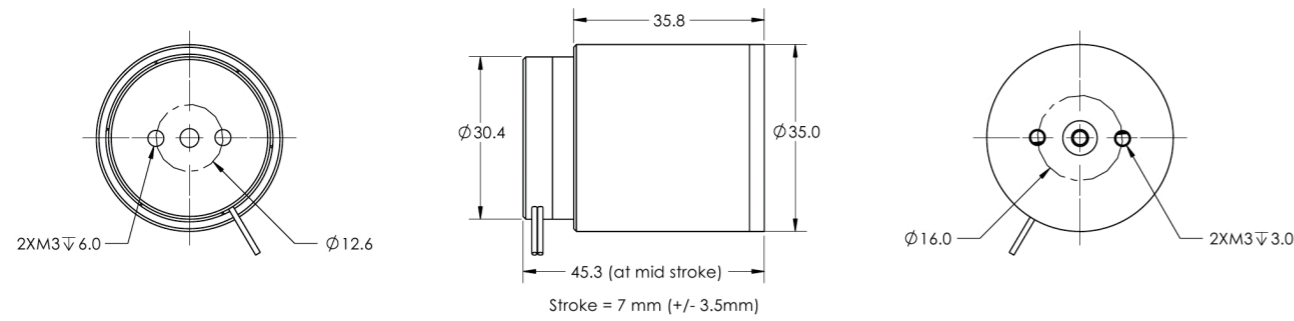

AVM 40-HF-6.5

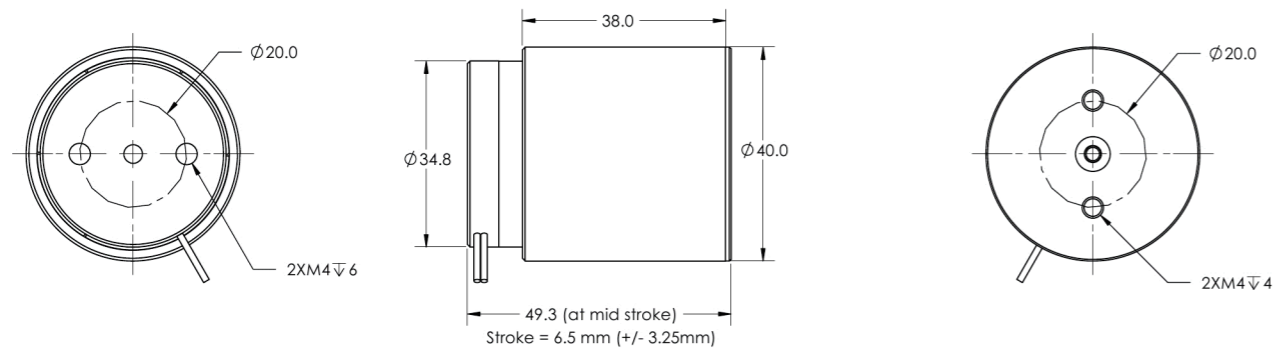

AVM 50-HF-10

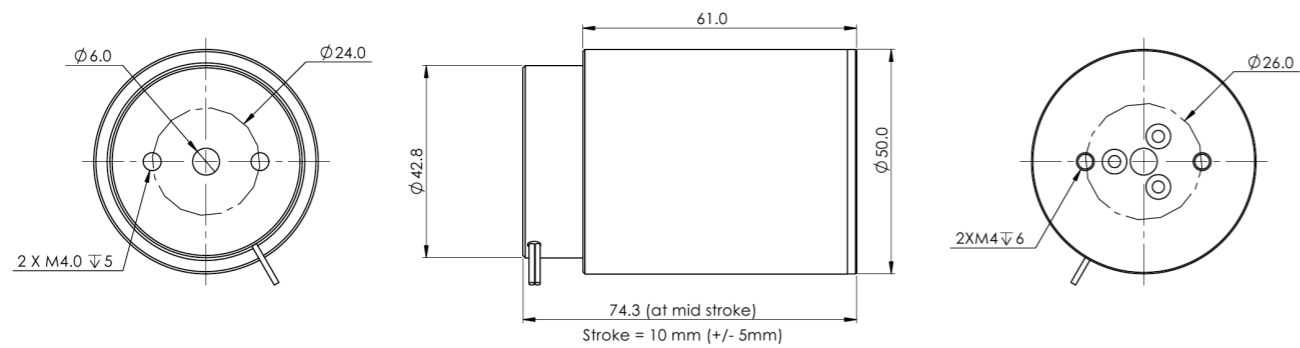

Dimensions

(High Force Serie) **AVM**

AVM 60-HF-10

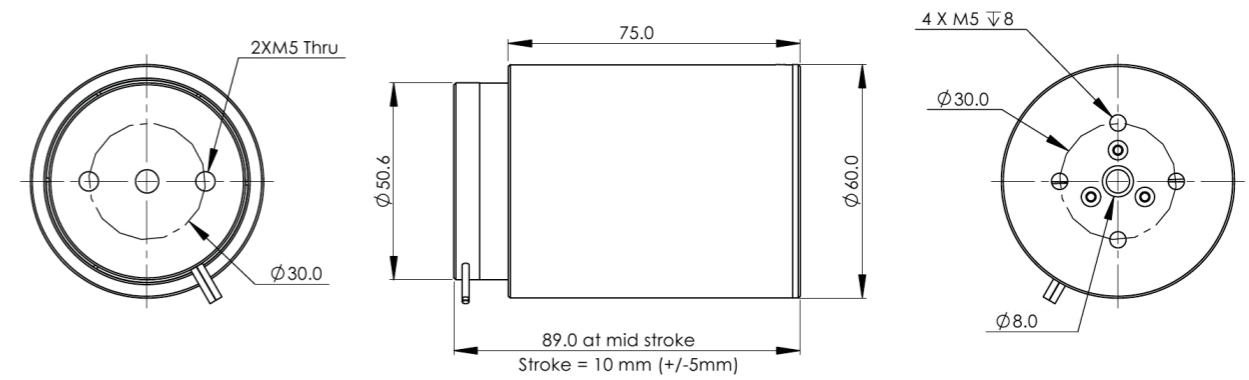

AVM 90-HF-10

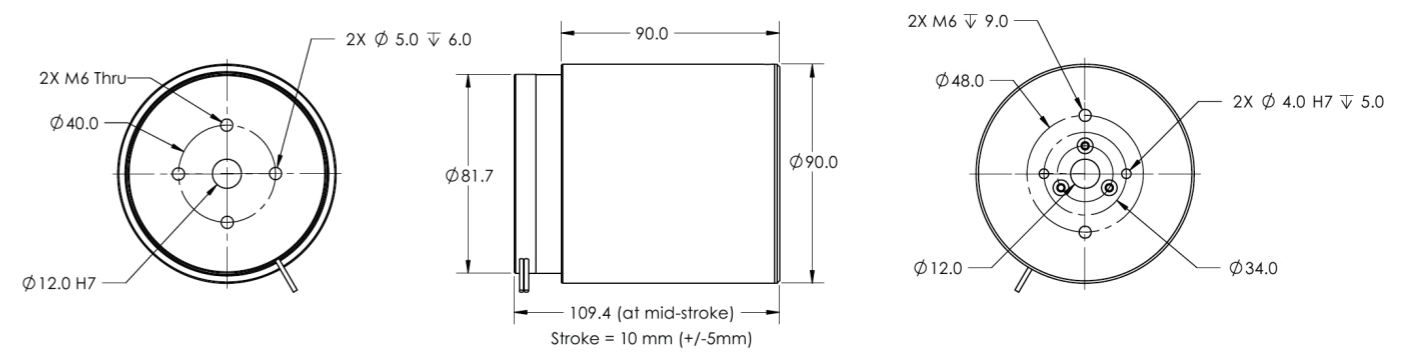

AVM 100-HF-10

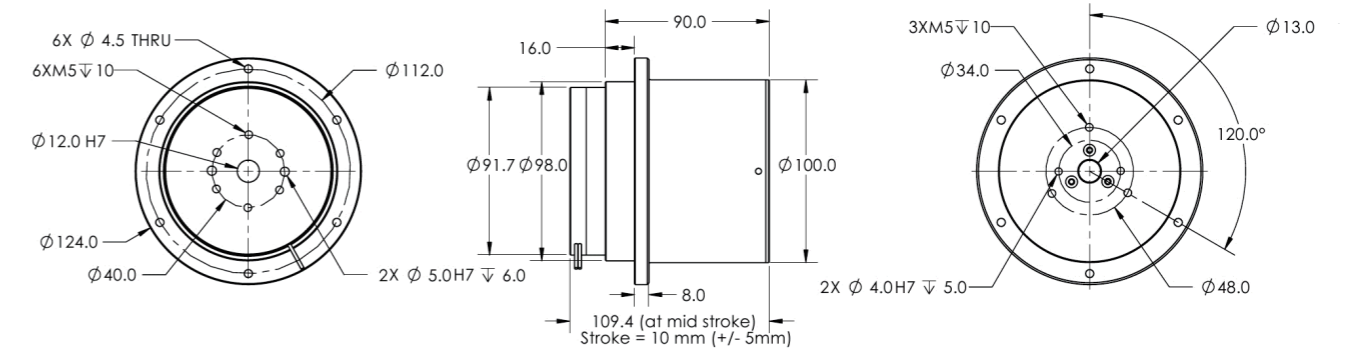

(High Force Series) AVM

Dimensions

AVM 130-HF-25

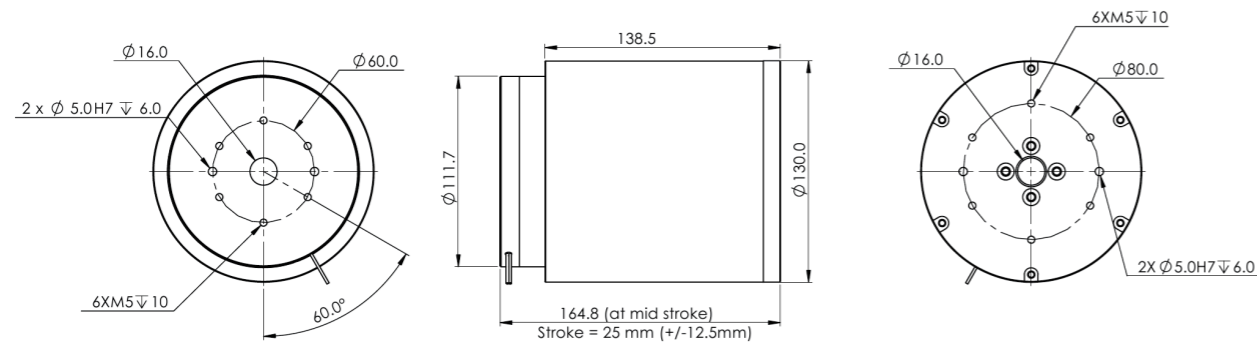

AVM 250-HF-20

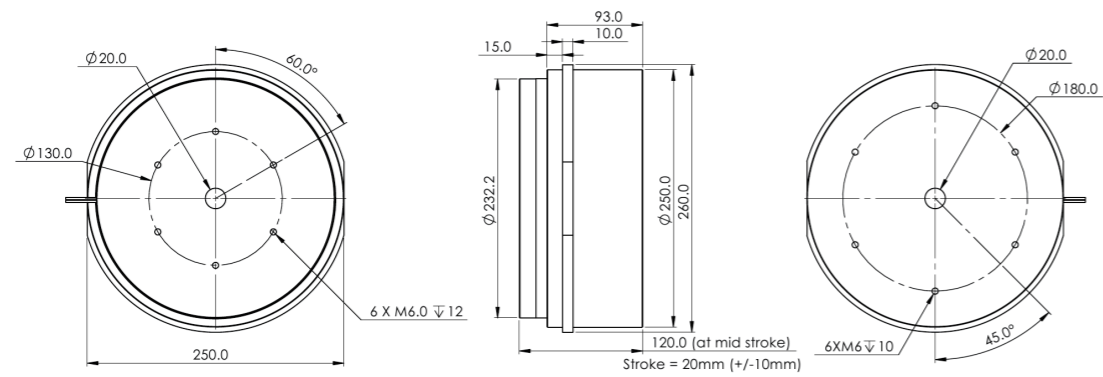

AVM 20-10

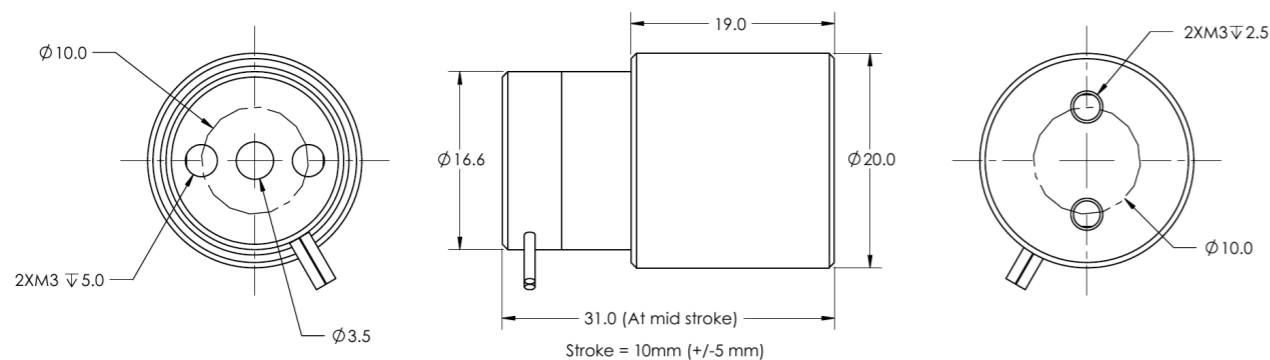

(Special Models) AVM

Specifications

Model	Units	AVM14-HF-4-C19	AVM14-10-C56	AVM 20-HF-6-C28
Stroke	mm	4	10	6
Force sensitivity (at mid stroke)	N/A	1.88	0.82	4.74
Back EMF constant	V/(m/s)	1.88	0.82	4.74
Continuous force (at 100 °C) ^①	N	2.44	0.98	5.69
Peak force	N	7.33	2.95	17.06
Resistance ^②	ohms	1.93	2.24	4.85
Inductance ^②	mH	0.14	0.24	0.56
Voltage at peak force	V	7.53	8.06	17.46
Continuous current (coil at 100 °C)	A	1.30	1.20	1.20
Peak current	A	3.90	3.60	3.60
Max voltage	Vdc	60	60	60
Actuator constant	N/Sqrt(W)	1.35	0.55	2.15
Continuous power	W	3.26	3.23	6.98
Electrical time constant	ms	0.073	0.107	0.115
Mechanical time constant	ms	3.822	10.019	2.914
Clearance of coil	mm	0.35	0.35	0.50
Power at peak force	W	29.36	29.03	62.86
Thermal dissipation constant	W/°C	0.043	0.043	0.093
Max coil temperature	°C	100	100	100
Coil assembly mass	g	7.0	3.0	13.5
Core assembly mass	g	13.7	13.6	47.5

Model	Units	AVM24-HF-5-C13	AVM 30-7-C60	AVM35-HF-15-C22
Stroke	mm	5	7	15
Force sensitivity (at mid stroke)	N/A	8.40	6.20	24.70
Back EMF constant	V/(m/s)	8.40	6.20	24.70
Continuous force (at 100 °C) ^①	N	5.88	5.64	19.76
Peak force	N	31.92	24.80	98.80
Resistance ^②	ohms	8.24	5.50	16.60
Inductance ^②	mH	1.69	1.52	7.11
Voltage at peak force	V	31.31	22.00	66.40
Continuous current (coil at 100 °C)	A	0.70	0.91	0.80
Peak current	A	3.80	4.00	4.00
Max voltage	Vdc	60	60	60
Actuator constant	N/Sqrt(W)	2.93	2.64	6.06
Continuous power	W	4.04	4.55	8.50
Electrical time constant	ms	0.205	0.276	0.428
Mechanical time constant	ms	2.511	2.189	2.196
Clearance of coil	mm	0.50	0.60	0.50
Power at peak force	W	118.99	88.00	265.60
Thermal dissipation constant	W/°C	0.054	0.061	0.113
Max coil temperature	°C	100	100	100
Coil assembly mass	g	21.5	15.3	80.7
Core assembly mass	g	82.0	86.2	261.0

① Continuous force measured without any additional mounting plate or heat sink on coil

② Measured at 25 °C

Specifications

(Special Models) **AVM**

Model	Units	AVM35-HF-8-C35	AVM35-HF-10-C31	AVM 40-20-C18
Stroke	mm	8	10	20
Force sensitivity (at mid stroke)	N/A	34.29	20.90	10.53
Back EMF constant	V/(m/s)	34.29	20.90	10.53
Continuous force (at 100 °C) ^①	N	27.43	16.72	8.11
Peak force	N	137.16	83.60	47.39
Resistance ^②	ohms	16.89	12.02	11.00
Inductance ^②	mH	6.89	4.96	6.22
Voltage at peak force	V	67.56	48.08	49.50
Continuous current (coil at 100 °C)	A	0.80	0.80	0.77
Peak current	A	4.00	4.00	4.50
Max voltage	Vdc	60	60	60
Actuator constant	N/Sqrt(W)	8.34	6.03	3.17
Continuous power	W	8.65	6.15	6.52
Electrical time constant	ms	0.408	0.413	0.565
Mechanical time constant	ms	1.224	2.146	6.448
Clearance of coil	mm	0.50	0.50	0.60
Power at peak force	W	270.24	192.32	222.75
Thermal dissipation constant	W/°C	0.115	0.082	0.087
Max coil temperature	°C	100	100	100
Coil assembly mass	g	85.2	78.0	65.0
Core assembly mass	g	371.4	285.7	205.0

Model	Units	AVM 40-HF-6.4-C11-A	AVM 50-HF-10-C15-A	AVM 50-HF-10-C34-A
Stroke	mm	6.4	10	10
Force sensitivity (at mid stroke)	N/A	14.20	21.00	31.31
Back EMF constant	V/(m/s)	14.20	21.00	31.31
Continuous force (at 100 °C) ^①	N	18.18	25.20	37.57
Peak force	N	99.40	105.00	156.55
Resistance ^②	ohms	5.42	7.80	7.80
Inductance ^②	mH	1.38	5.30	5.30
Voltage at peak force	V	37.94	39.00	39.00
Continuous current (coil at 100 °C)	A	1.28	1.20	1.20
Peak current	A	7.00	5.00	5.00
Max voltage	Vdc	60	60	60
Actuator constant	N/Sqrt(W)	6.10	7.52	11.21
Continuous power	W	8.88	11.23	11.23
Electrical time constant	ms	0.255	0.679	0.679
Mechanical time constant	ms	1.317	2.512	1.146
Clearance of coil	mm	0.50	0.60	0.60
Power at peak force	W	265.58	195.00	195.00
Thermal dissipation constant	W/°C	0.118	0.150	0.150
Max coil temperature	°C	100	100	100
Coil assembly mass	g	49.0	142.0	144.0
Core assembly mass	g	195.0	482.0	628.0

- ① Continuous force measured without any additional mounting plate or heat sink on coil
- ② Measured at 25 °C

Specifications

(Special Models) **AVM**

Model	Units	AVM 75-HF-25-C12	AVM75-38-C39	AVM 80-12-C8
Stroke	mm	25	38	12
Force sensitivity (at mid stroke)	N/A	33.70	13.72	21.40
Back EMF constant	V/(m/s)	33.70	13.72	21.40
Continuous force (at 100 °C) ^①	N	124.69	45.26	33.71
Peak force	N	572.90	192.02	192.60
Resistance ^②	ohms	2.72	2.35	6.36
Inductance ^②	mH	2.88	1.89	1.62
Voltage at peak force	V	46.24	32.90	57.24
Continuous current (coil at 100 °C)	A	3.70	3.30	1.58
Peak current	A	17.00	14.00	9.00
Max voltage	Vdc	60	60	60
Actuator constant	N/Sqrt(W)	20.43	8.95	8.49
Continuous power	W	37.24	25.59	15.78
Electrical time constant	ms	1.059	0.804	0.255
Mechanical time constant	ms	1.700	6.671	1.722
Clearance of coil	mm	0.50	0.50	0.60
Power at peak force	W	786.08	460.60	515.16
Thermal dissipation constant	W/°C	0.496	0.341	0.210
Max coil temperature	°C	100	100	100
Coil assembly mass	g	710.0	534.0	124.0
Core assembly mass	g	1940.0	1277.0	1262.4

Model	Units	AVM 90-30-C77	AVM90-HF-5-C40-A	AVM 130-HF-10-C29-A	AVM 150-HF-20-C53
Stroke	mm	30	5	10	20
Force sensitivity (at mid stroke)	N/A	14.47	15.78	46.40	97.63
Back EMF constant	V/(m/s)	14.47	15.78	46.40	97.63
Continuous force (at 100 °C) ^①	N	57.30	62.49	162.40	585.77
Peak force	N	202.60	220.92	487.20	1757.30
Resistance ^②	ohms	2.9	1.21	0.88	4.40
Inductance ^②	mH	6.61	0.75	0.82	2.60
Voltage at peak force	V	40.60	16.94	9.24	79.20
Continuous current (coil at 100 °C)	A	4.0	3.96	3.50	6.00
Peak current	A	14.0	14.00	10.50	18.00
Max voltage	Vdc	120	120	120	120
Actuator constant	N/Sqrt(W)	8.50	14.35	49.46	46.54
Continuous power	W	45.48	18.97	10.78	158.40
Electrical time constant	ms	2.3	0.620	0.932	0.591
Mechanical time constant	ms	10.4	2.076	0.441	0.692
Clearance of coil	mm	0.65	0.65	0.55	0.75
Power at peak force	W	568.40	237.16	97.02	1425.60
Thermal dissipation constant	W/°C	0.606	0.253	0.144	2.112
Max coil temperature	°C	100	100	100	100
Coil assembly mass	g	751.2	427.2	1080.0	1500.0
Core assembly mass	g	1135.1	1514.6	5300.0	12700.0

- ① Continuous force measured without any additional mounting plate or heat sink on coil
- ② Measured at 25 °C

■ Dimensions (Special Models) **AVM**

■ AVM 14-10-C56

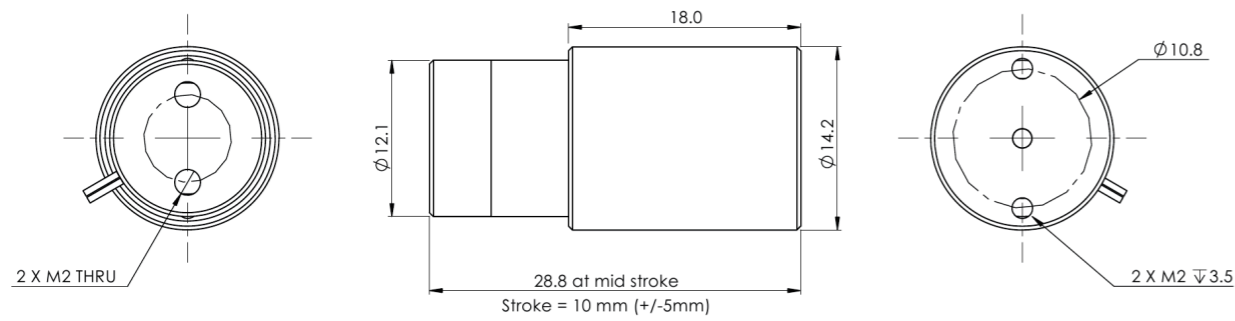

■ AVM 14-HF-4-C19

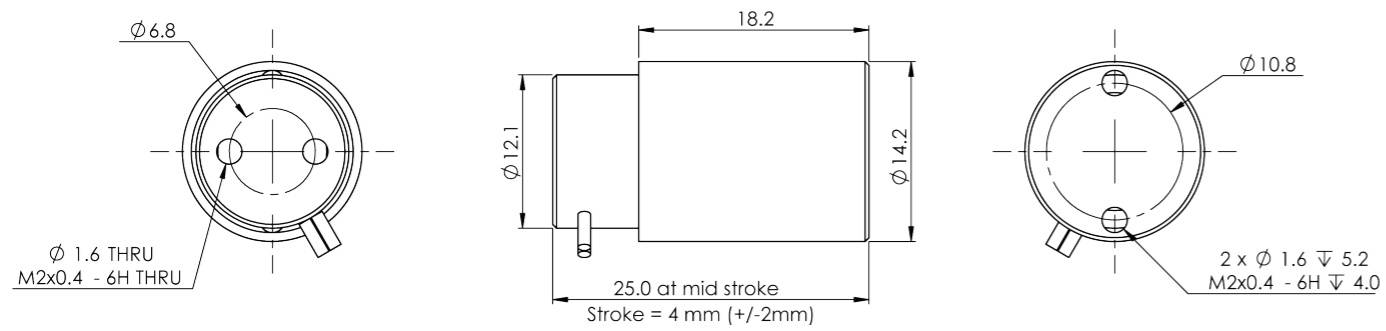

■ AVM 24-HF-6-C28

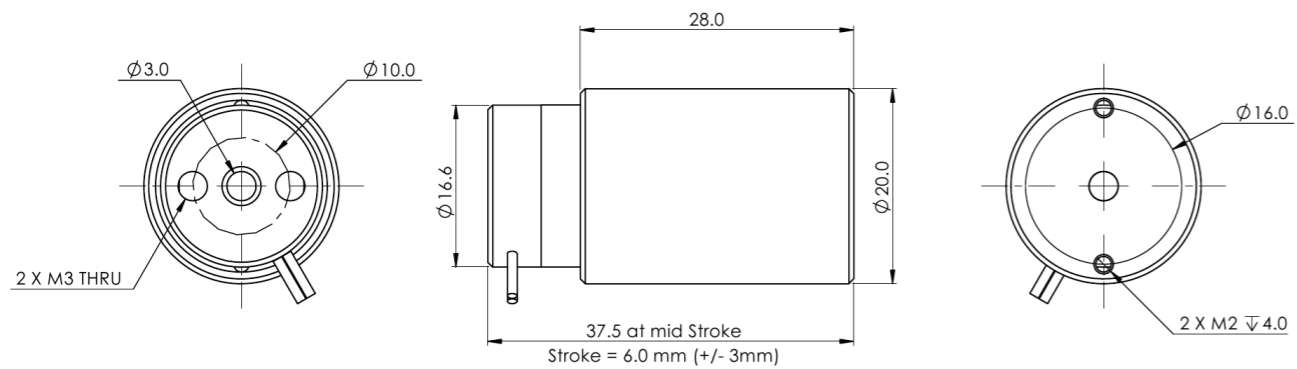

■ Dimensions (Special Models) **AVM**

■ AVM 24-HF-5-C13

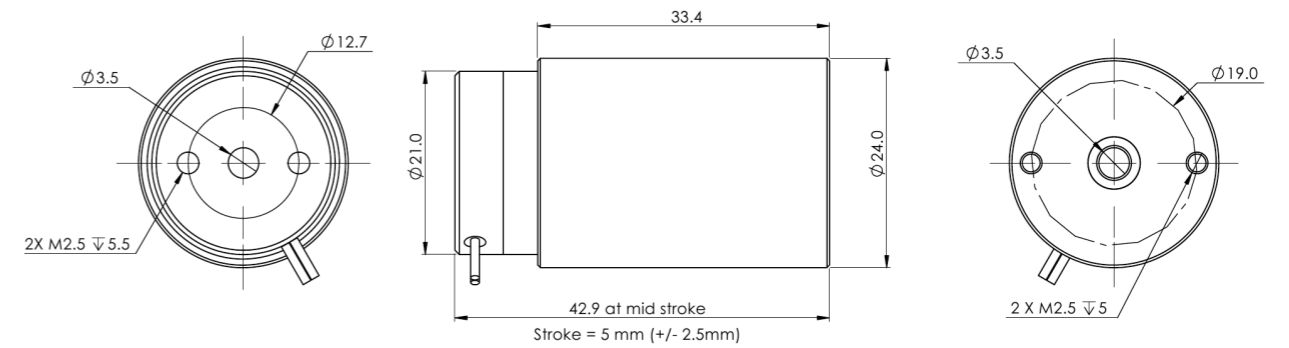

■ AVM 30-7-C60

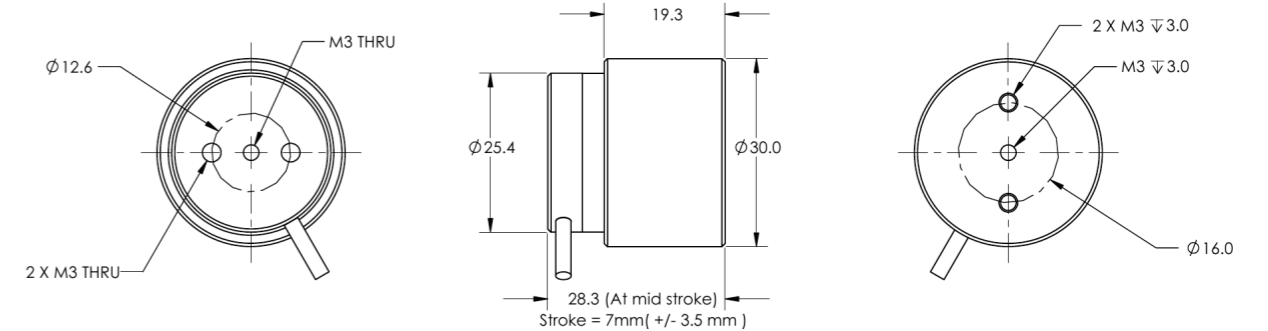

■ AVM 35-HF-8-C35

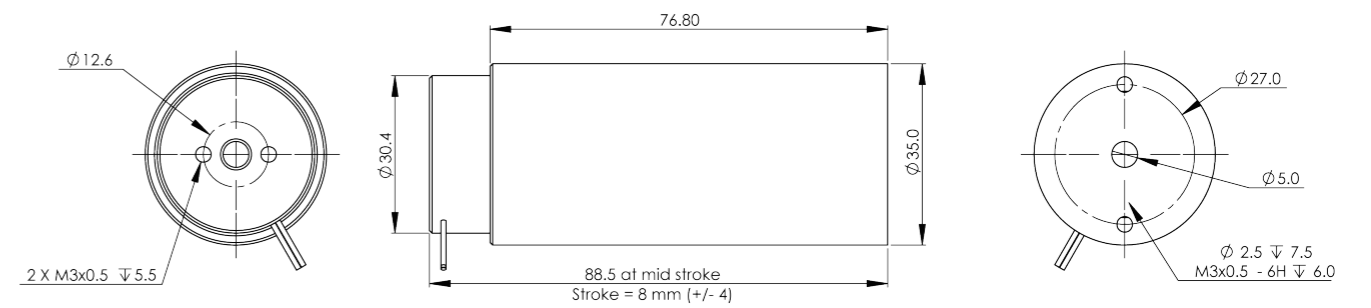

Dimensions

(Special Models) AVM

AVM 35-HF-10-C31

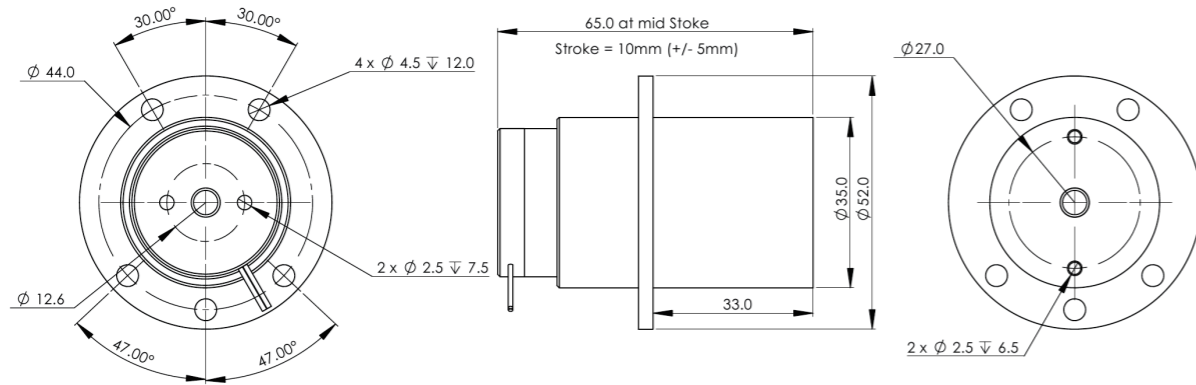

AVM 35-HF-15-C22

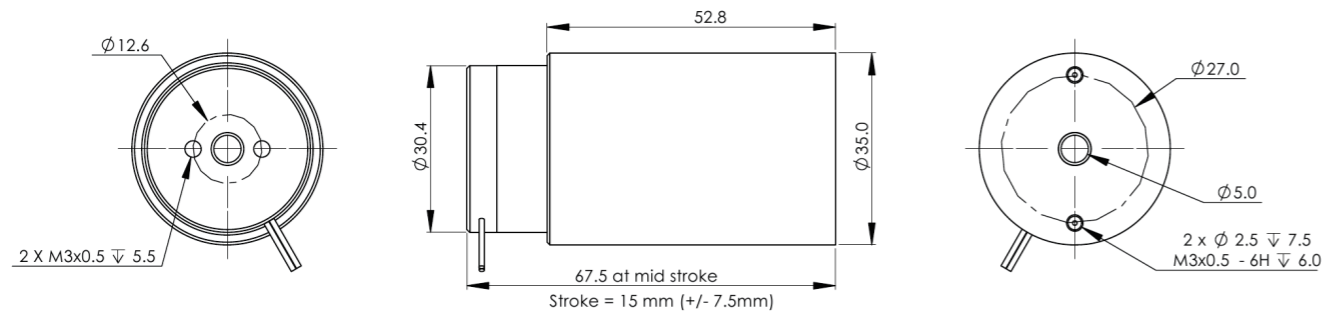

AVM 40-20-C18

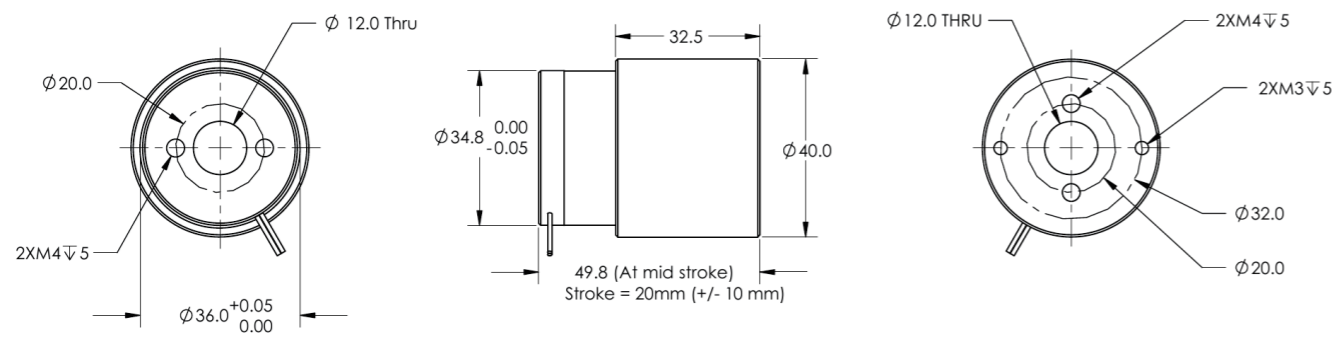

Dimensions

(Special Models) AVM

AVM 40-HF-6.4-C11-A

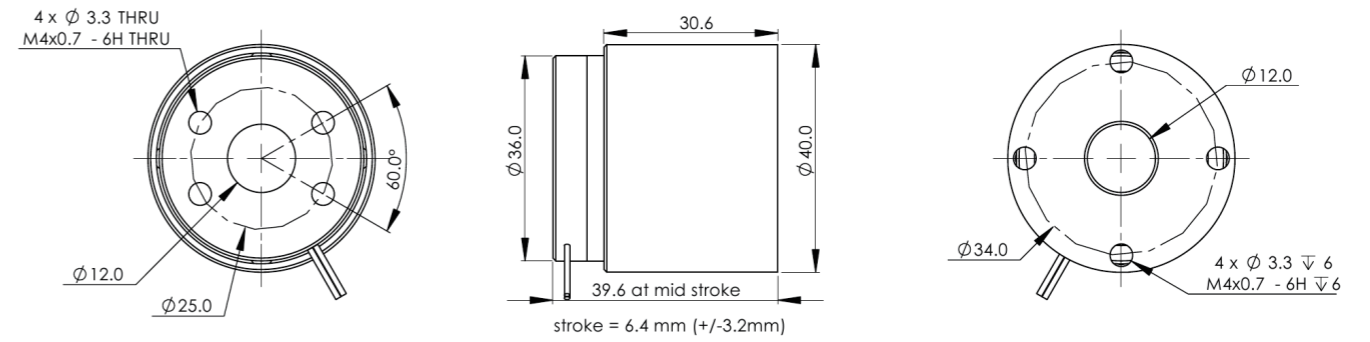

AVM 50-HF-10-C15

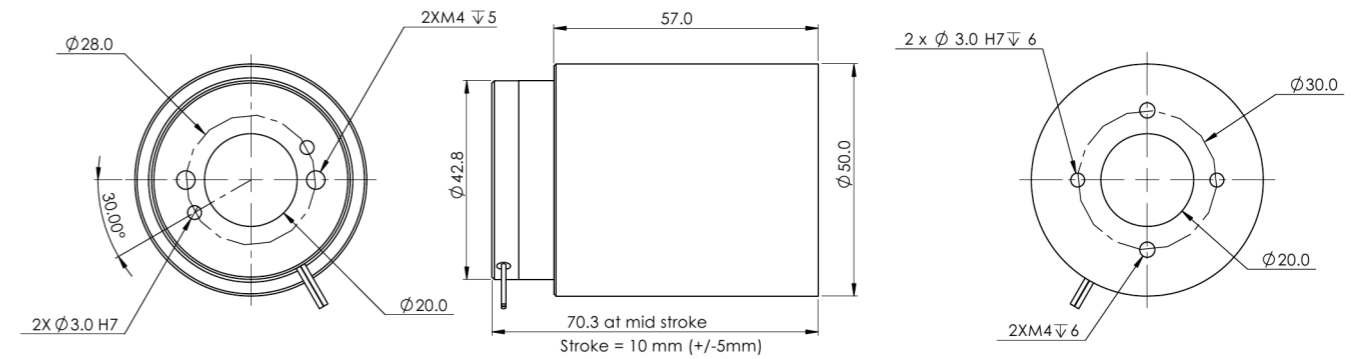

AVM 50-HF-10-C34-A

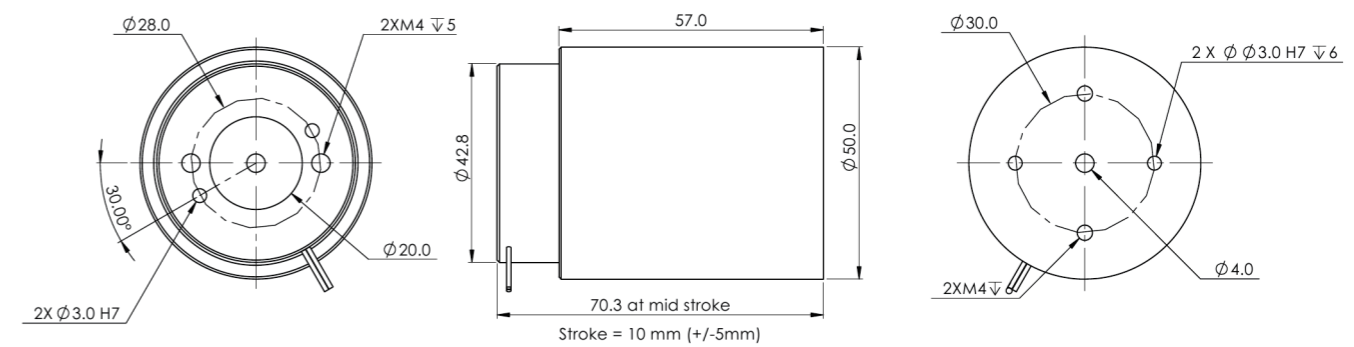

Dimensions

(Special Models) **AVM**

AVM 75-38-C39

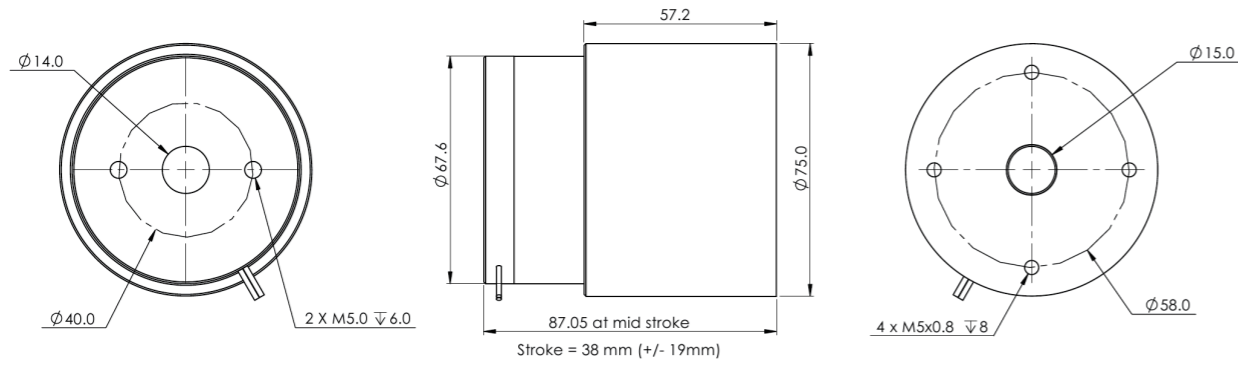

AVM 75-HF-25-C12

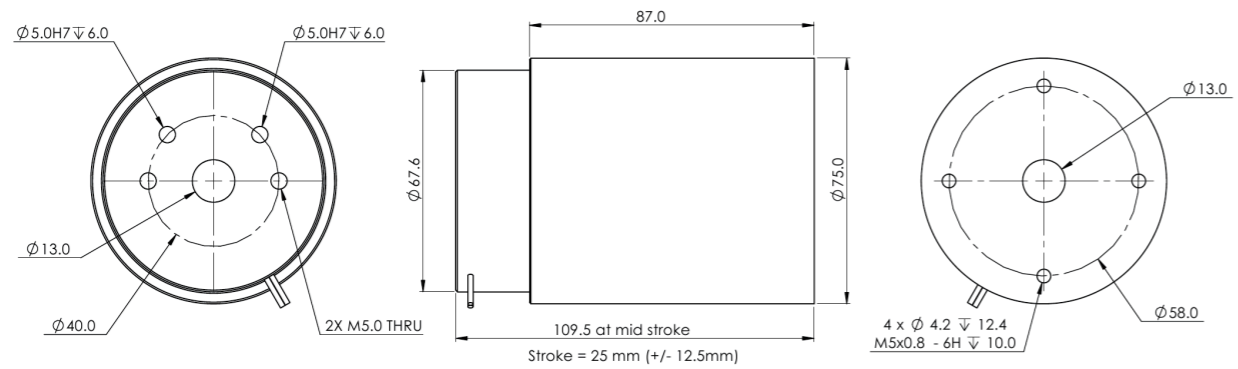

AVM 80-12-C8

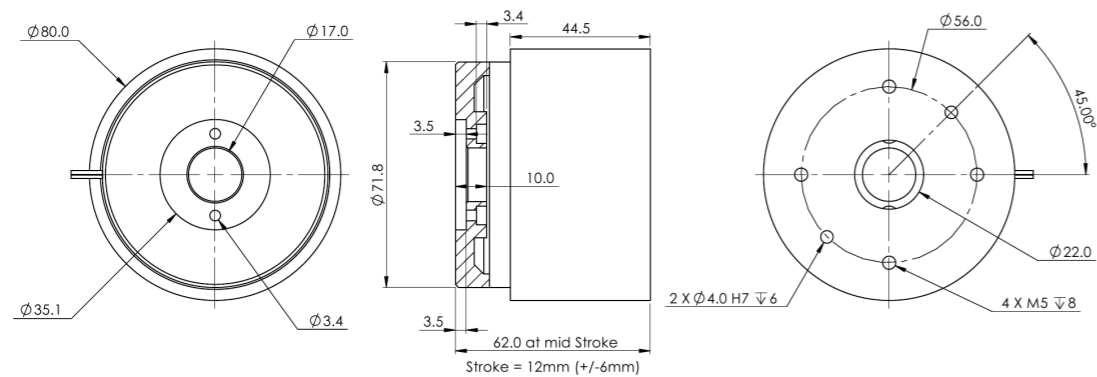

Dimensions

(Special Models) **AVM**

AVM 90-30-C77

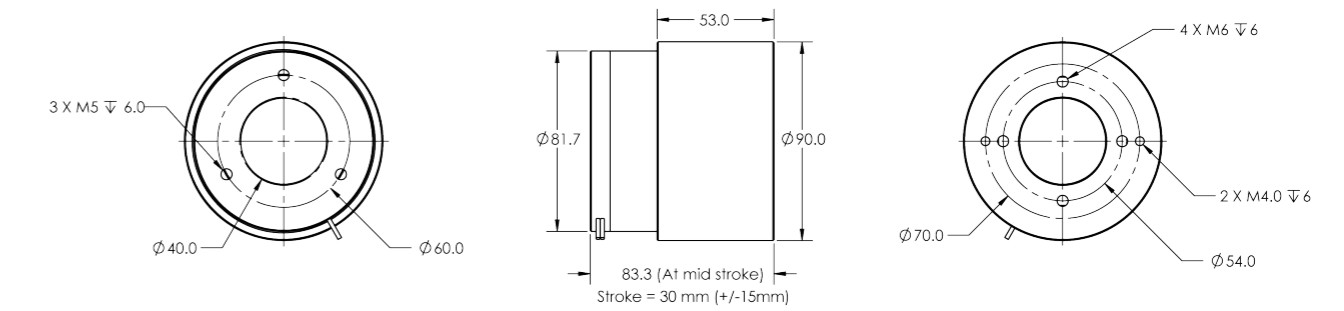

AVM 90-HF-5-C40-A

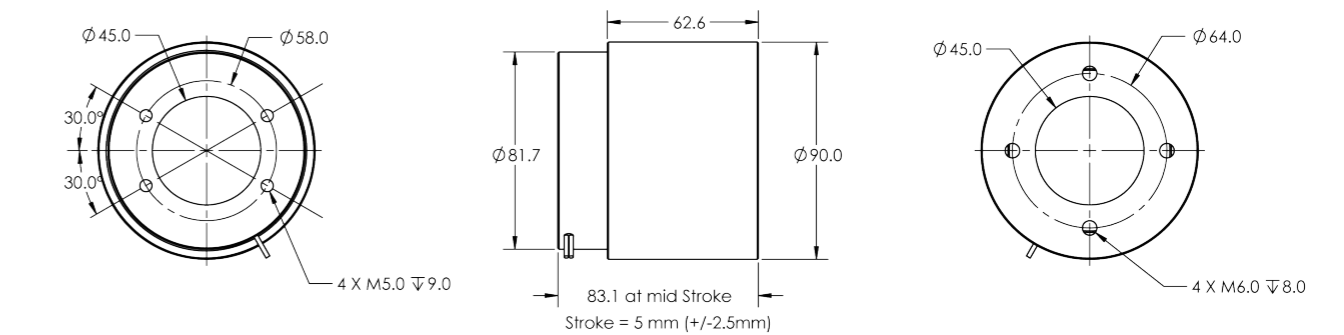

AVM 130-HF-10-C29-A

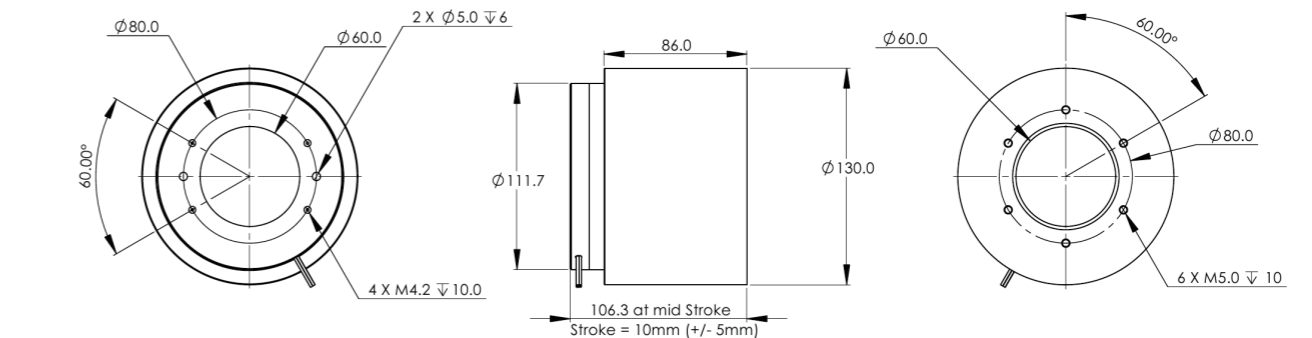

(Special Models) AVM

■ Dimensions

■ AVM 150-HF-20-C53

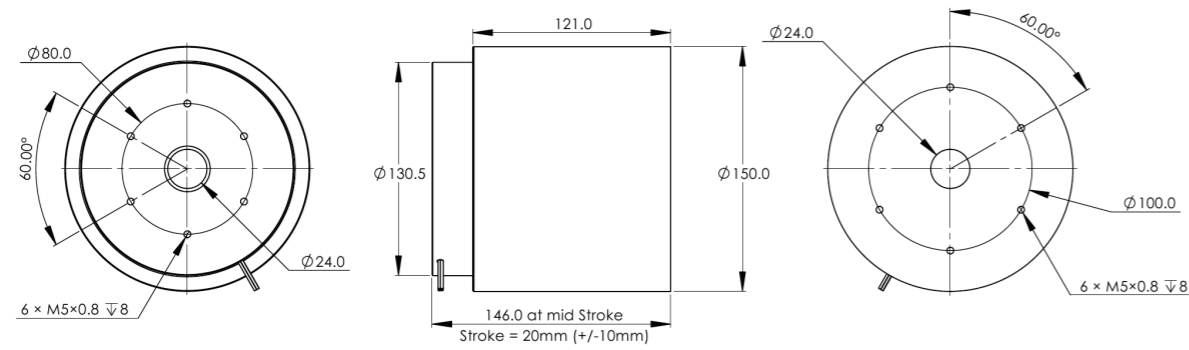

AVM

■ Part Numbering



Coil (Standard Series)

AVM 30-15-0.5

Model & Stroke(mm)
AVM30

Cable Length (m)

0.5

Stroke(mm)

15



TDS Precision Products GmbH
Industriestrasse 1a
CH-8157 Dielsdorf

T + 41 44 885 30 80
info@tds-pp.com
www.tds-pp.com