

Data Sheet for Angle Sensors

Optical incremental kit encoder

Series SPFH



TDS Precision Products GmbH
Industriestrasse 1a
CH-8157 Dielsdorf

T + 41 44 885 30 80
info@tds-pp.com
www.tds-pp.com



- Optical resolution 250 to 4096 pulses / 360°.
- 16 mm housing
- Housing with depth 8.9 mm / shaft diameter 1.5 or 2 mm
- Operating voltage 5 VDC
- Output TTL
- 5-pole connector

The SPFH 16mm kit encoder is designed to provide incremental signals in a very small space. The SPFH uses an innovative clip-on encoder disc that can accommodate shaft diameters of 1.5mm or 2mm. The SPFH is designed as a micro-optical encoder for one-time mounting. The base has mounting holes for two M1.6-0.35 screws, length 3 mm on a 10 mm pitch circle. The encoder cover is simply snapped onto the base. Connection is via a 5-pin connector with reverse polarity protection.

Electrical Data	TTL
Output signal	5 V - A, B, Z
Pulse number	250..4096 ppr.
Output voltage high	≥ 4.7 V @ 4 mA load (4.9 V @ no load)
Output voltage low	≤ 0.4 V @ 4 mA with load (0.1 V @ no load)
Max. Output frequency	
Pulse count 250/256	200 kHz
Pulse count 500/512	400 kHz
Pulse count 1000/1024	800 kHz
Pulse count 2000/2048	1.6 MHz
Pulse count 4000/4096	1.85 MHz
Supply voltage	5 VDC ±10 %
Current consumption (without load)	≤ 26 mA (typ. 18 mA)
Output load	4 mA per channel (A, B, or Z)
Output electronics	TTL
Switch-on delay (rise time, fall time)	Typ. 80 (max. 135 ns)

Mechanical and Environmental Data, Miscellaneous	
Mechanical angle of rotation /stroke 1.)	360° without stop
Max. Actuating speed	
Number of pulses 250/500/1000/2000	48000 ppr.
Pulse count 256/512/1024/2048	46875 ppr.
Pulse count 4000	27750 ppr.
Pulse count 4096	27099 ppr.
Max. acceleration	250000 rad/sec ²
Operating temperature range	-40..+100 °C
Storage temperature range	-40..+100 °C

Data Sheet for Angle Sensors

Optical incremental kit encoder

Series SPFH

Mechanical Data. Environmental Conditions. Miscellaneous

Vibration (IEC 68-2-6. Test Fc)	20 g / 10 bis 2000 Hz / sinusoidal
Shock (IEC 68-2-27. Test Ea)	75 g / 6 ms / half-sine
Enclosure diameter	16 mm
Housing depth	8.92 mm
Shaft diameter (customer side)	1.5 mm or 2 mm
Shaft type	Hub for solid shaft
Max. Eccentricity + Radial Clearance	0.05 mm
Max. Axial play	±0.25 mm
Max. Shaft length incl. axial play	7.75 mm
Min. shaft length incl. axial play	6 mm
Connection type	Hirose connector DF52-5P-0.8C (5-pin)
Connection position	Radial
Mass	ca. 14 g
Mounting parts included in delivery	Assembly tools consisting of a centring tool and a spacer tool
Tightening torque Mounting screws	< 10-25 Ncm
Material shaft	Stainless steel for ball bearings Brass for plain bearing
Material housing	Plastic
Moment of inertia of encoder disc	2e-8 kg•cm•s ²
Encoder disc material	Mylar
Noise immunity ESD. IEC 61000-4-2	±12 kV

1.) According IEC 60393

2.) Determined by climatic conditions according to IEC 68-1, para. 5.3.1 without load collectives

Data Sheet for Angle Sensors

Optical incremental kit encoder

Series SPFH

Order Code

Description	Selection: standard=black/bold , possible <i>options=grey/italic</i>					
Series	SPFH					
Shaft diameter* Ø1.5 mm (1/8") Ø2 mm		1,5 2				
Resolution: 250 ppr. 256 ppr. 500 ppr. 512 ppr. 1000 ppr. 1024 ppr. 2000 ppr. 2048 ppr. 4000 ppr. 4096 ppr.			256 250 500 512 1000 1024 2000 2048 4000 4096			
Power supply: Standard: 5 V				5		
Output signals: Standard: A+B+Z					BZ	
Output electronics: Standard: TTL						TTL

* Diameter of the customer-side hub

For high volume requirements, you can obtain these and other customised solutions

For example:

- Cables and connector assemblies

Order example SPFH

Requirements:

Shaft diameter 2 mm, Resolution 256 ppr. , Supply voltage 5 V, 3 channels A+B+Z, Output TTL

Example order code: SPFH 2 256 5 BZ TTL

Data Sheet for Angle Sensors



Optical incremental kit encoder

Series SPFH

Drawing

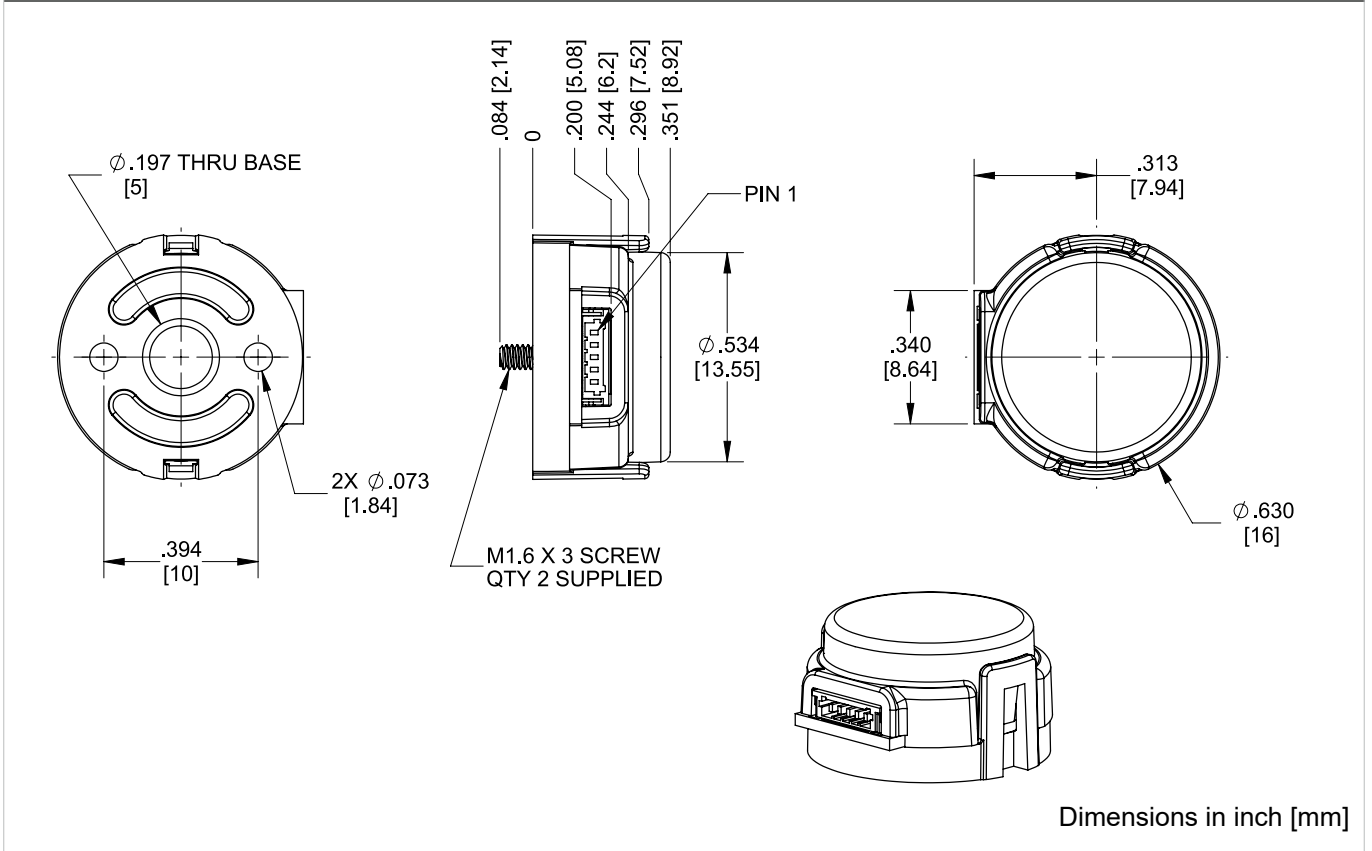

Pin assignment SPFH

Function	PIN
GND	1
Index Z	2
Channel A	3
+5 VDC, Supply Voltage	4
Channel B	5

Data Sheet for Angle Sensors

Optical incremental kit encoder

Series SPFH

Phase Relation

- The specifications apply to the entire operating temperature range
- They indicate the largest possible error over one full revolution

Parameter	Symbol	Min.	Typ.	Max.	Unit
Symmetry	X, Y	150	180	210	°
Quadrature	Q	60	90	120	°
Width of index pulse	Po	60	90	120	°
Channel Z Rise time after fall of chan. A or B	t1		10		ns
Channel Z Fall time after fall of chan. A or B	t2		10		ns

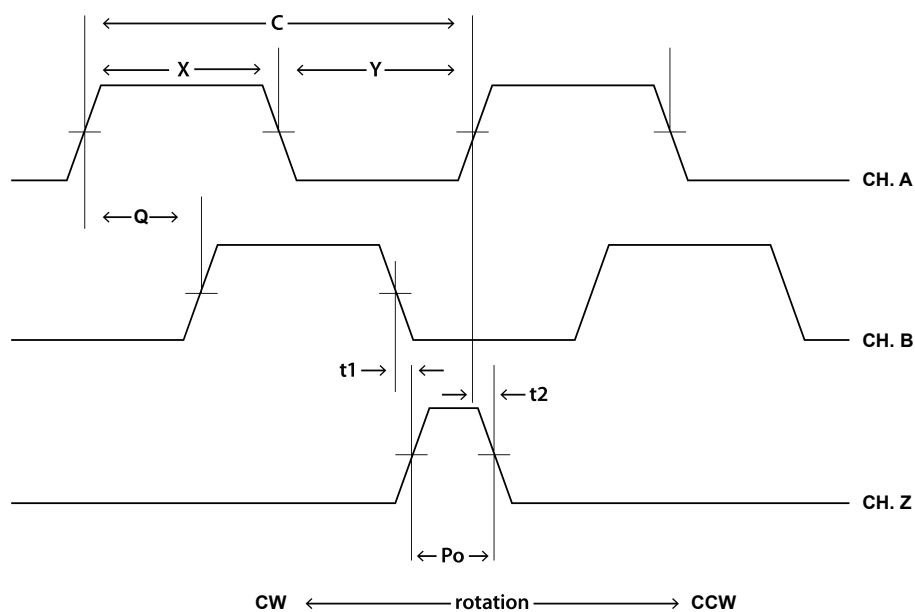

Index (Z)

The index output goes high once per revolution, coinciding with the low states of channels A and B, nominally 1/4 of a cycle (90°).

One cycle (C)

360 electrical degrees (°). Each cycle can be decoded into 1, 2 or 4 states, which is called multiplication of resolution x1, x2 or x4.

Quadrature (Q)

The phase shift between channels in degrees, nominally 90°.

Symmetry

A measure of the relationship between (X) and (Y) in electrical degrees, nominally 180°.

Data Sheet for Angle Sensors

Optical incremental kit encoder

Series SPFH

Assembly Instructions

Note: The SPFH is designed for one-time installation

Step 1:

Place the base over the shaft and onto the mounting surface. Centering tool onto the shaft so that it contacts and aligns the base. Applying light pressure to the centering tool, secure the base to the mounting surface using two screws.

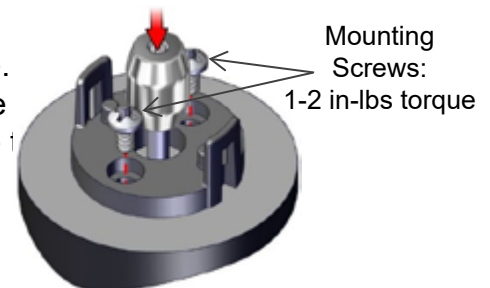

Step 2:

Remove the centering tool. Place the PCB onto the base surface, aligning the board with the two mounting posts. Note that the base is symmetrical allowing the connector to exit out either side. Check to make sure that the PCB is fully seated against the base.

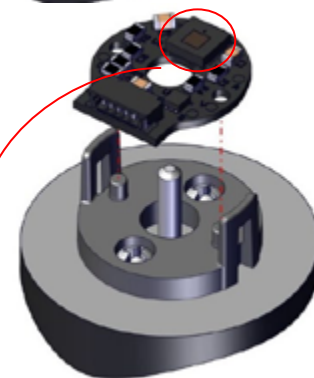

Caution:

To prevent damage, avoid directly touching the optical sensor area when handling the PCB.

Step 3:

Place the hubdisk onto the shaft with the longer end of hub toward the base. Position the spacer tool onto the hub such that the notches are aligned with the latches of the base. Press down firmly until the tool bottoms out on the base latches.

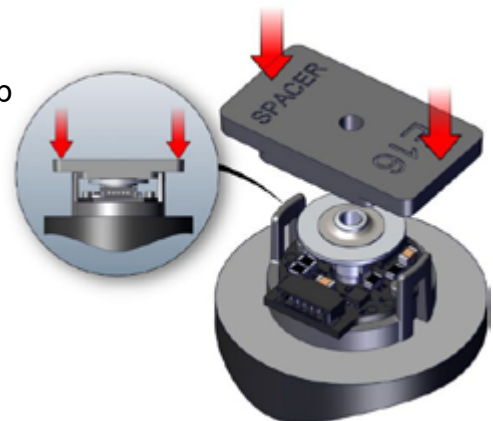

Caution:

While installing the hubdisk ensure that the hub bore is parallel to the shaft. Forcing the hub onto the shaft at an angle may cause permanent damage to the hub. Handle disk with care to prevent scratching the disk.

Step 4:

Remove the spacer tool and snap the cover down onto the base, (1). With your thumb and finger, squeeze the base latches together to ensure they are fully engaged with the cover, (2).

